

(12) INTERNATIONAL APPLICATION PUBLISHED UNDER THE PATENT COOPERATION TREATY (PCT)

(19) World Intellectual Property
Organization
International Bureau



(43) International Publication Date
29 January 2004 (29.01.2004)

PCT

(10) International Publication Number
WO 2004/009950 A1

(51) International Patent Classification⁷: **E21B 19/16**

(21) International Application Number:
PCT/US2003/020694

(22) International Filing Date: 1 July 2003 (01.07.2003)

(25) Filing Language: English

(26) Publication Language: English

(30) Priority Data:
60/398,061 24 July 2002 (24.07.2002) US

(71) Applicant (for all designated States except US): **ENVEN-
TURE GLOBAL TECHNOLOGY** [US/US]; 16200 A
Park Row, Houston, TX 77084 (US).

[US/US]; 2011 Willow Point, Kingwood, TX 77330
(US). **HOCKADAY, Joel** [US/US]; 17318 Ginger Fields
Lane, Tomball, TX 77375 (US). **WADDELL, Kevin,
K.** [US/US]; 11007 Sprucedale Court, Houston, TX
77070 (US). **RING, Lev** [RU/US]; 14126 Heatherhill
Place, Houston, TX 77077 (US). **BULLOCK, Michael**
[US/US]; 19827 Sky Country, Houston, TX 77094 (US).
COOK, Robert, Lance [US/US]; 934 Caswell Court,
Katy, TX 77450 (US). **KENDZIORA, Larry** [US/US];
6518 Williams School Court, Needville, TX 77461 (US).
BRISCO, David, Paul [US/US]; 405 Westridge Drive,
Duncan, OK 73533 (US). **JACKSON, Tance** [US/US];
7209 Ridgemoor Lane, Plano, TX 75025 (US). **RAO,
Vikram** [US/US]; 6429 Edloe, Houston, TX 77005 (US).

(74) Agents: **MATTINGLY, Todd** et al.; Haynes and Boone,
LLP, Suite 4300, 1000 Louisiana Street, Houston, TX
77002-5012 (US).

(72) Inventors; and
(75) Inventors/Applicants (for US only): **COSTA, Scott**

(81) Designated States (national): AE, AG, AL, AM, AT, AU,
AZ, BA, BB, BG, BR, BY, BZ, CA, CH, CN, CO, CR, CU.

[Continued on next page]

(54) Title: **DUAL WELL COMPLETION SYSTEM**

(57) Abstract: A tubular sleeve (210) is coupled to and overlaps the threaded connection (12, 24) between a pair of adjacent tubular members 14, 26.

WO 2004/009950 A1

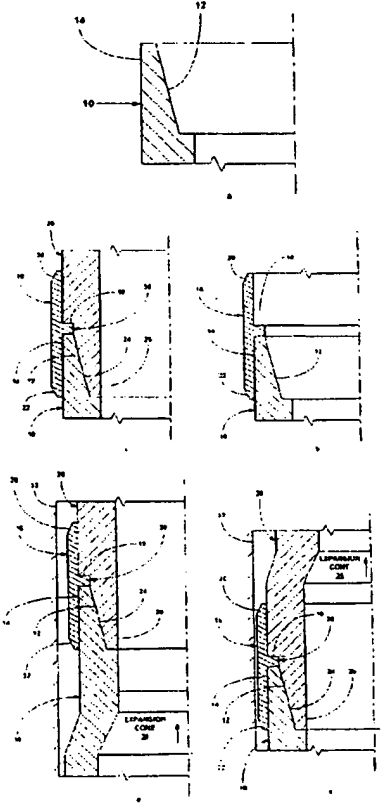



CZ, DE, DK, DM, DZ, EC, EE, ES, FI, GB, GD, GE, GH, GM, HR, HU, ID, IL, IN, IS, JP, KE, KG, KP, KR, KZ, LC, LK, LR, LS, LT, LU, LV, MA, MD, MG, MK, MN, MW, MX, MZ, NO, NZ, OM, PH, PL, PT, RO, RU, SC, SD, SE, SG, SK, SL, TJ, TM, TN, TR, TT, TZ, UA, UG, US, UZ, VC, VN, YU, ZA, ZM, ZW.

- of inventorship (Rule 4.17(iv)) for US only
- of inventorship (Rule 4.17(iv)) for US only
- of inventorship (Rule 4.17(iv)) for US only
- of inventorship (Rule 4.17(iv)) for US only
- of inventorship (Rule 4.17(iv)) for US only
- of inventorship (Rule 4.17(iv)) for US only
- of inventorship (Rule 4.17(iv)) for US only
- of inventorship (Rule 4.17(iv)) for US only

(84) Designated States (regional): ARIPO patent (GH, GM, KE, LS, MW, MZ, SD, SL, SZ, TZ, UG, ZM, ZW), Eurasian patent (AM, AZ, BY, KG, KZ, MD, RU, TJ, TM), European patent (AT, BE, BG, CH, CY, CZ, DE, DK, EE, ES, FI, FR, GB, GR, HU, IE, IT, LU, MC, NL, PT, RO, SE, SI, SK, TR), OAPI patent (BF, BJ, CF, CG, CI, CM, GA, GN, GQ, GW, ML, MR, NE, SN, TD, TG).

- Published:**
- with international search report
 - with amended claims

Declarations under Rule 4.17:

- of inventorship (Rule 4.17(iv)) for US only

For two-letter codes and other abbreviations, refer to the "Guidance Notes on Codes and Abbreviations" appearing at the beginning of each regular issue of the PCT Gazette.

DUAL WELL COMPLETION SYSTEM**Cross Reference To Related Applications**

[001] The present application claims the benefit of the filing dates of (1) U.S. provisional patent application serial no. 60/398,061, attorney docket no 25791.110, filed on 7/24/2002, which is a continuation-in-part of U.S. provisional patent application serial no. 60/372,632, attorney docket no. 25791.101, filed on 4/15/2002, which was a continuation-in-part of U.S. provisional patent application serial no. 60/372,048, attorney docket no. 25791.93, filed on April 12, 2002, which was a continuation-in-part of U.S. provisional patent application serial no. 60/346,309, attorney docket no. 25791.92, filed on 1/7/2002, the disclosures of which are incorporated herein by reference.

[002] The present application is a continuation-in-part of U.S. provisional patent application serial no. 60/398,061, attorney docket no. 25791.106, filed on July 19, 2002, which was a continuation-in-part of U.S. provisional patent application serial no. 60/372,632, attorney docket no. 25791.101, filed on 4/15/2002, which was a continuation-in-part of U.S. provisional patent application serial no. 60/372,048, attorney docket no. 25791.93, filed on April 12, 2002, which was a continuation-in-part of U.S. provisional patent application serial no. 60/346,309, attorney docket no. 25791.92, filed on 1/7/2002, the disclosures of which are incorporated herein by reference.

[003] The present application is related to the following: (1) U.S. patent application serial no. 09/454,139, attorney docket no. 25791.03.02, filed on 12/3/1999, (2) U.S. patent application serial no. 09/510,913, attorney docket no. 25791.7.02, filed on 2/23/2000, (3) U.S. patent application serial no. 09/502,350, attorney docket no. 25791.8.02, filed on 2/10/2000, (4) U.S. patent application serial no. 09/440,338, attorney docket no. 25791.9.02, filed on 11/15/1999, (5) U.S. patent application serial no. 09/523,460, attorney docket no. 25791.11.02, filed on 3/10/2000, (6) U.S. patent application serial no. 09/512,895, attorney docket no. 25791.12.02, filed on 2/24/2000, (7) U.S. patent application serial no. 09/511,941, attorney docket no. 25791.16.02, filed on 2/24/2000, (8) U.S. patent application serial no. 09/588,946, attorney docket no. 25791.17.02, filed on 6/7/2000, (9) U.S. patent application serial no. 09/559,122, attorney docket no. 25791.23.02, filed on 4/26/2000, (10) PCT patent application serial no. PCT/US00/18635, attorney docket no. 25791.25.02, filed on 7/9/2000, (11) U.S. provisional patent application serial no. 60/162,671, attorney docket no. 25791.27, filed on 11/1/1999, (12) U.S. provisional patent application serial no. 60/154,047, attorney docket no. 25791.29, filed on 9/16/1999, (13) U.S. provisional patent application serial no. 60/159,082, attorney docket no. 25791.34, filed on 10/12/1999, (14) U.S. provisional patent application serial no. 60/159,039, attorney docket no. 25791.36, filed on 10/12/1999, (15) U.S. provisional patent application serial no. 60/159,033, attorney docket no. 25791.37, filed on 10/12/1999, (16) U.S. provisional patent application serial no. 60/212,359, attorney docket no. 25791.38, filed on 6/19/2000, (17) U.S. provisional patent application serial no. 60/165,228, attorney docket no. 25791.39, filed on 11/12/1999, (18) U.S. provisional patent application serial no. 60/221,443,

attorney docket no. 25791.45, filed on 7/28/2000, (19) U.S. provisional patent application serial no. 60/221,645, attorney docket no. 25791.46, filed on 7/28/2000, (20) U.S. provisional patent application serial no. 60/233,638, attorney docket no. 25791.47, filed on 9/18/2000, (21) U.S. provisional patent application serial no. 60/237,334, attorney docket no. 25791.48, filed on 10/2/2000, (22) U.S. provisional patent application serial no. 60/270,007, attorney docket no. 25791.50, filed on 2/20/2001, (23) U.S. provisional patent application serial no. 60/262,434, attorney docket no. 25791.51, filed on 1/17/2001, (24) U.S. provisional patent application serial no. 60/259,486, attorney docket no. 25791.52, filed on 1/3/2001, (25) U.S. provisional patent application serial no. 60/303,740, attorney docket no. 25791.61, filed on 7/6/2001, (26) U.S. provisional patent application serial no. 60/313,453, attorney docket no. 25791.59, filed on 8/20/2001, (27) U.S. provisional patent application serial no. 60/317,985, attorney docket no. 25791.67, filed on 9/6/2001, (28) U.S. provisional patent application serial no. 60/3318,386, attorney docket no. 25791.67.02, filed on 9/10/2001, (29) U.S. utility patent application serial no. 09/969,922, attorney docket no. 25791.69, filed on 10/3/2001, (30) U.S. utility patent application serial no. 10/016,467, attorney docket no. 25791.70, filed on 12/10/2001; (31) U.S. provisional patent application serial no. 60/343,674, attorney docket no. 25791.68, filed on 12/27/2001; (32) U.S. provisional patent application serial no. 60/346,309, attorney docket no. 25791.92, filed on 1/7/2002; (33) U.S. provisional patent application serial no. 60/372,048, attorney docket no. 25791.93, filed on 4/12/2002; (34) U.S. provisional patent application serial no. 60/380,147, attorney docket no. 25791.104, filed on 5/6/2002; (35) U.S. provisional patent application serial no. 60/387,486, attorney docket no. 25791.107, filed on 6/10/2002; (36) U.S. provisional patent application serial no. 60/387,961, attorney docket no. 25791.108, filed on 6/12/2002; (37) U.S. provisional patent application serial no. 60/391,703, attorney docket no. 25791.90, filed on 6/26/2002; and (38) U.S. provisional patent application serial no. 60/397,284, attorney docket no. 25791.106, filed on 7/19/2002, the disclosures of which are incorporated herein by reference.

Background of the Invention

[004] This invention relates generally to oil and gas exploration, and in particular to forming and repairing wellbore casings to facilitate oil and gas exploration.

[005] During oil exploration, a wellbore typically traverses a number of zones within a subterranean formation. Wellbore casings are then formed in the wellbore by radially expanding and plastically deforming tubular members that are coupled to one another by threaded connections. Existing methods for radially expanding and plastically deforming tubular members coupled to one another by threaded connections are not always reliable or produce satisfactory results. In particular, the threaded connections can be damaged during the radial expansion process. Furthermore, the threaded connections between adjacent tubular members, whether radially expanded or not, are typically not sufficiently coupled to permit the transmission of energy through the tubular members from the surface to a downhole location.

[006] The present invention is directed to overcoming one or more of the limitations of the existing processes for radially expanding and plastically deforming tubular members coupled to one another by threaded connections.

Summary of the Invention

[007] According to one aspect of the present invention, a method is provided that includes coupling an end of a first tubular member to an end of a tubular sleeve, coupling an end of a second tubular member to another end of the tubular sleeve, coupling the ends of the first and second tubular members, and radially expanding and plastically deforming the first tubular member and the second tubular member.

[008] According to another aspect of the present invention, an apparatus is provided that includes a tubular sleeve, a first tubular member coupled to an end of the tubular sleeve, and a second tubular member coupled to another end of the tubular sleeve and the first tubular member.

[009] According to another aspect of the present invention, a method of extracting geothermal energy from a subterranean source of geothermal energy is provided that includes drilling a borehole that traverses the subterranean source of geothermal energy, positioning a first casing string within the borehole, radially expanding and plastically deforming the first casing string within the borehole, positioning a second casing string within the borehole that traverses the subterranean source of geothermal energy, overlapping a portion of the second casing string with a portion of the first casing string, radially expanding and plastically deforming the second casing string within the borehole, and extracting geothermal energy from the subterranean source of geothermal energy using the first and second casing strings.

[0010] According to another aspect of the present invention, an apparatus for extracting geothermal energy from a subterranean source of geothermal energy is provided that includes a borehole that traverses the subterranean source of geothermal energy, a first casing string positioned within the borehole, and a second casing positioned within the borehole that overlaps with the first casing string that traverses the subterranean source of geothermal energy. The first casing string and the second casing string are radially expanded and plastically deformed within the borehole.

[0011] According to another aspect of the present invention, a method is provided that includes coupling an end of a first tubular member to an end of a tubular sleeve, coupling an end of a second tubular member to another end of the tubular sleeve, coupling the ends of the first and second tubular members, injecting a pressurized fluid through the first and second tubular members, determining if any of the pressurized fluid leaks through the coupled ends of the first and second tubular members, and if a predetermined amount of the pressurized fluid leaks through the coupled ends of the first and second tubular members, then coupling a tubular sleeve to the ends of the first and second tubular members and radially expanding and plastically deforming only the portions of the first and second tubular members proximate the tubular sleeve.

[0012] According to another aspect of the present invention, a method is provided that includes coupling an end of a first tubular member to an end of a tubular sleeve, coupling an end of a second tubular member to another end of the tubular sleeve, coupling the ends of the first and second tubular members, radially expanding and plastically deforming the first tubular member and the second tubular member, and transmitting energy through the first and second tubular members.

[0013] According to another aspect of the present invention, a system is provided that includes a source of energy, a borehole formed in the earth, a first tubular member positioned within the borehole operably coupled to the source of energy, a second tubular member positioned within the borehole coupled to the first tubular member, and a tubular sleeve positioned within the borehole coupled to the first and second tubular members. The first tubular member, second tubular member, and the tubular sleeve are plastically deformed into engagement with one another.

[0014] According to another aspect of the present invention, a method of operating a well for extracting hydrocarbons from a subterranean formation is provided that includes drilling a borehole into the earth that traverses the subterranean formation, positioning a wellbore casing in the borehole, transmitting energy through the wellbore casing, and extracting hydrocarbons from the subterranean formation.

[0015] According to another aspect of the present invention, a method of extracting fluidic materials from first and second producing subterranean formations traversed by a borehole is provided that includes coupling an end of a first tubular member to an end of a tubular sleeve, coupling an end of a second tubular member to another end of the first tubular sleeve, coupling the ends of the first and second tubular members, positioning the coupled first tubular member, second tubular member and first tubular sleeve within the borehole proximate the first producing subterranean formation, radially expanding and plastically deforming the first tubular member, the second tubular member, and the first tubular sleeve within the borehole, coupling an end of a third tubular member to an end of a second tubular sleeve, coupling an end of a fourth tubular member to another end of the second tubular sleeve, coupling the ends of the third and fourth tubular members, positioning the coupled third tubular member, fourth tubular member and second tubular sleeve within the radially expanded and coupled first tubular member, second tubular member, and first tubular sleeve and the borehole proximate the second producing subterranean formation, radially expanding and plastically deforming the third tubular member, the fourth tubular member, and the second tubular sleeve within the borehole, extracting fluidic materials from the first producing subterranean formation through an annular passage defined between the radially expanded and coupled first tubular member, second tubular member, and first tubular sleeve and the radially expanded and coupled third tubular member, fourth tubular member, and second tubular sleeve, and extracting fluidic materials from the second producing subterranean formation through a passage defined within the radially expanded and coupled third tubular member, fourth tubular member, and second tubular sleeve.

[0016] According to another aspect of the present invention, a system for extracting fluidic materials from first and second producing subterranean formations traversed by a borehole has been described that

includes means for coupling an end of a first tubular member to an end of a tubular sleeve, means for coupling an end of a second tubular member to another end of the first tubular sleeve, means for coupling the ends of the first and second tubular members, means for positioning the coupled first tubular member, second tubular member and first tubular sleeve within the borehole proximate the first producing subterranean formation, means for radially expanding and plastically deforming the first tubular member, the second tubular member, and the first tubular sleeve within the borehole, means for coupling an end of a third tubular member to an end of a second tubular sleeve, means for coupling an end of a fourth tubular member to another end of the second tubular sleeve, means for coupling the ends of the third and fourth tubular members, means for positioning the coupled third tubular member, fourth tubular member and second tubular sleeve within the radially expanded and coupled first tubular member, second tubular member, and first tubular sleeve and the borehole proximate the second producing subterranean formation, means for radially expanding and plastically deforming the third tubular member, the fourth tubular member, and the second tubular sleeve within the borehole, means for extracting fluidic materials from the first producing subterranean formation through an annular passage defined between the radially expanded and coupled first tubular member, second tubular member, and first tubular sleeve and the radially expanded and coupled third tubular member, fourth tubular member, and second tubular sleeve, and means for extracting fluidic materials from the second producing subterranean formation through a passage defined within the radially expanded and coupled third tubular member, fourth tubular member, and second tubular sleeve.

Brief Description of the Drawings

[0017] FIG. 1a is a fragmentary cross-sectional illustration of a first tubular member having an internally threaded connection at an end portion.

[0018] Fig. 1b is a fragmentary cross-sectional illustration of the placement of a tubular sleeve onto the end portion of the first tubular member of Fig. 1a.

[0019] Fig. 1c is a fragmentary cross-sectional illustration of the coupling of an externally threaded connection at an end portion of a second tubular member to the internally threaded connection at the end portion of the first tubular member of Fig. 1b.

[0020] Fig. 1d is a fragmentary cross-sectional illustration of the radial expansion and plastic deformation of a portion of the first tubular member of Fig. 1c.

[0021] Fig. 1e is a fragmentary cross sectional of the continued radial expansion and plastic deformation of the threaded connection between the first and second tubular members and the tubular sleeve of Fig. 1d.

[0022] Fig. 2a is a fragmentary cross-sectional illustration of the radial expansion and plastic deformation of a portion of a first tubular member having an internally threaded connection at an end portion, an alternative embodiment of a tubular sleeve supported by the end portion of the first tubular

member, and a second tubular member having an externally threaded portion coupled to the internally threaded portion of the first tubular member.

[0023] Fig. 2b is a fragmentary cross sectional of the continued radial expansion and plastic deformation of the threaded connection between the first and second tubular members and the tubular sleeve of Fig. 2a.

[0024] Fig. 3a is a fragmentary cross-sectional illustration of the radial expansion and plastic deformation of a portion of a first tubular member having an internally threaded connection at an end portion, an alternative embodiment of a tubular sleeve supported by the end portion of the first tubular member, and a second tubular member having an externally threaded portion coupled to the internally threaded portion of the first tubular member.

[0025] Fig. 3b is a fragmentary cross sectional of the continued radial expansion and plastic deformation of the threaded connection between the first and second tubular members and the tubular sleeve of Fig. 3a.

[0026] Fig. 4a is a fragmentary cross-sectional illustration of the radial expansion and plastic deformation of a portion of a first tubular member having an internally threaded connection at an end portion, an alternative embodiment of a tubular sleeve having an external sealing element supported by the end portion of the first tubular member, and a second tubular member having an externally threaded portion coupled to the internally threaded portion of the first tubular member.

[0027] Fig. 4b is a fragmentary cross sectional of the continued radial expansion and plastic deformation of the threaded connection between the first and second tubular members and the tubular sleeve of Fig. 4a.

[0028] Fig. 5a is a fragmentary cross-sectional illustration of the radial expansion and plastic deformation of a portion of a first tubular member having an internally threaded connection at an end portion, an alternative embodiment of a tubular sleeve supported by the end portion of the first tubular member, and a second tubular member having an externally threaded portion coupled to the internally threaded portion of the first tubular member.

[0029] Fig. 5b is a fragmentary cross sectional of the continued radial expansion and plastic deformation of the threaded connection between the first and second tubular members and the tubular sleeve of Fig. 5a.

[0030] Fig. 6a is a fragmentary cross sectional illustration of an alternative embodiment of a tubular sleeve.

[0031] Fig. 6b is a fragmentary cross sectional illustration of an alternative embodiment of a tubular sleeve.

[0032] Fig. 6c is a fragmentary cross sectional illustration of an alternative embodiment of a tubular sleeve.

- [0033] Fig. 6d is a fragmentary cross sectional illustration of an alternative embodiment of a tubular sleeve.
- [0034] FIG. 7a is a fragmentary cross-sectional illustration of a first tubular member having an internally threaded connection at an end portion.
- [0035] Fig. 7b is a fragmentary cross-sectional illustration of the placement of an alternative embodiment of a tubular sleeve onto the end portion of the first tubular member of Fig. 7a.
- [0036] Fig. 7c is a fragmentary cross-sectional illustration of the coupling of an externally threaded connection at an end portion of a second tubular member to the internally threaded connection at the end portion of the first tubular member of Fig. 7b.
- [0037] Fig. 7d is a fragmentary cross-sectional illustration of the radial expansion and plastic deformation of a portion of the first tubular member of Fig. 1c.
- [0038] Fig. 7e is a fragmentary cross sectional of the continued radial expansion and plastic deformation of the threaded connection between the first and second tubular members and the tubular sleeve of Fig. 7d.
- [0039] FIG. 8a is a fragmentary cross-sectional illustration of a first tubular member having an internally threaded connection at an end portion.
- [0040] Fig. 8b is a fragmentary cross-sectional illustration of the placement of an alternative embodiment of a tubular sleeve onto the end portion of the first tubular member of Fig. 8a.
- [0041] Fig. 8c is a fragmentary cross-sectional illustration of the coupling of the tubular sleeve of Fig. 8b to the end portion of the first tubular member.
- [0042] Fig. 8d is a fragmentary cross-sectional illustration of the coupling of an externally threaded connection at an end portion of a second tubular member to the internally threaded connection at the end portion of the first tubular member of Fig. 8b.
- [0043] Fig. 8e is a fragmentary cross-sectional illustration of the coupling of the tubular sleeve of Fig. 8d to the end portion of the second tubular member.
- [0044] Fig. 8f is a fragmentary cross-sectional illustration of the radial expansion and plastic deformation of a portion of the first tubular member of Fig. 8e.
- [0045] Fig. 8g is a fragmentary cross sectional of the continued radial expansion and plastic deformation of the threaded connection between the first and second tubular members and the tubular sleeve of Fig. 8f.
- [0046] FIG. 9a is a fragmentary cross-sectional illustration of a first tubular member having an internally threaded connection at an end portion.
- [0047] Fig. 9b is a fragmentary cross-sectional illustration of the placement of an alternative embodiment of a tubular sleeve onto the end portion of the first tubular member of Fig. 9a.

[0048] Fig. 9c is a fragmentary cross-sectional illustration of the coupling of an externally threaded connection at an end portion of a second tubular member to the internally threaded connection at the end portion of the first tubular member of Fig. 9b.

[0049] Fig. 9d is a fragmentary cross-sectional illustration of the radial expansion and plastic deformation of a portion of the first tubular member of Fig. 9c.

[0050] Fig. 9e is a fragmentary cross sectional of the continued radial expansion and plastic deformation of the threaded connection between the first and second tubular members and the tubular sleeve of Fig. 9d.

[0051] FIG. 10a is a fragmentary cross-sectional illustration of a first tubular member having an internally threaded connection at an end portion.

[0052] Fig. 10b is a fragmentary cross-sectional illustration of the placement of an alternative embodiment of a tubular sleeve onto the end portion of the first tubular member of Fig. 10a.

[0053] Fig. 10c is a fragmentary cross-sectional illustration of the coupling of an externally threaded connection at an end portion of a second tubular member to the internally threaded connection at the end portion of the first tubular member of Fig. 10b.

[0054] Fig. 10d is a fragmentary cross-sectional illustration of the radial expansion and plastic deformation of a portion of the first tubular member of Fig. 10c.

[0055] Fig. 10e is a fragmentary cross sectional of the continued radial expansion and plastic deformation of the threaded connection between the first and second tubular members and the tubular sleeve of Fig. 10d.

[0056] FIG. 11a is a fragmentary cross-sectional illustration of a first tubular member having an internally threaded connection at an end portion.

[0057] Fig. 11b is a fragmentary cross-sectional illustration of the placement of an alternative embodiment of a tubular sleeve onto the end portion of the first tubular member of Fig. 11a.

[0058] Fig. 11c is a fragmentary cross-sectional illustration of the coupling of an externally threaded connection at an end portion of a second tubular member to the internally threaded connection at the end portion of the first tubular member of Fig. 11b.

[0059] Fig. 11d is a fragmentary cross-sectional illustration of the radial expansion and plastic deformation of a portion of the first tubular member of Fig. 11c.

[0060] Fig. 11e is a fragmentary cross sectional of the continued radial expansion and plastic deformation of the threaded connection between the first and second tubular members and the tubular sleeve of Fig. 11d.

[0061] FIG. 12a is a fragmentary cross-sectional illustration of a first tubular member having an internally threaded connection at an end portion.

[0062] Fig. 12b is a fragmentary cross-sectional illustration of the placement of an alternative embodiment of a tubular sleeve onto the end portion of the first tubular member of Fig. 12a.

[0063] Fig. 12c is a fragmentary cross-sectional illustration of the coupling of an externally threaded connection at an end portion of a second tubular member to the internally threaded connection at the end portion of the first tubular member of Fig. 12b.

[0064] Fig. 12d is a fragmentary cross-sectional illustration of the radial expansion and plastic deformation of a portion of the first tubular member of Fig. 12c.

[0065] Fig. 12e is a fragmentary cross sectional of the continued radial expansion and plastic deformation of the threaded connection between the first and second tubular members and the tubular sleeve of Fig. 12d.

[0066] Fig. 13a is a fragmentary cross-sectional illustration of the coupling of an end portion of an alternative embodiment of a tubular sleeve onto the end portion of a first tubular member.

[0067] Fig. 13b is a fragmentary cross-sectional illustration of the coupling of an end portion of a second tubular member to the other end portion of the tubular sleeve of Fig. 13a.

[0068] Fig. 13c is a fragmentary cross-sectional illustration of the radial expansion and plastic deformation of a portion of the first tubular member of Fig. 13b.

[0069] Fig. 13d is a fragmentary cross sectional of the continued radial expansion and plastic deformation of the threaded connection between the first and second tubular members and the tubular sleeve of Fig. 13c.

[0070] FIG. 14a is a fragmentary cross-sectional illustration of an end portion of a first tubular member.

[0071] Fig. 14b is a fragmentary cross-sectional illustration of the coupling of an end portion of an alternative embodiment of a tubular sleeve onto the end portion of the first tubular member of Fig. 14a.

[0072] Fig. 14c is a fragmentary cross-sectional illustration of the coupling of an end portion of a second tubular member to the other end portion of the tubular sleeve of Fig. 14b.

[0073] Fig. 14d is a fragmentary cross-sectional illustration of the radial expansion and plastic deformation of a portion of the first tubular member of Fig. 14c.

[0074] Fig. 14e is a fragmentary cross sectional of the continued radial expansion and plastic deformation of the threaded connection between the first and second tubular members and the tubular sleeve of Fig. 14d.

[0075] Fig. 15a is a fragmentary cross-sectional illustration of the coupling of an internally threaded end portion of a first tubular member to an externally threaded end portion of a second tubular member including a protective sleeve coupled to the end portions of the first and second tubular member.

[0076] Fig. 15b is a cross-sectional illustration of the first and second tubular members and the protective sleeve following the radial expansion of the first and second tubulars and the protective sleeve.

[0077] Fig. 15c is a fragmentary cross-sectional illustration of an alternative embodiment that includes a metallic foil for amorphously bonding the first and second tubular members of Figs. 15a and 15b during the radial expansion and plastic deformation of the tubular members.

[0078] Fig. 16 is a cross-sectional illustration of a borehole including a plurality of overlapping radially expanded wellbore casings that traverses a subterranean source of geothermal energy.

[0079] Fig. 17a is a fragmentary cross-sectional illustration of the coupling of an internally threaded end portion of a first tubular member to an externally threaded end portion of a second tubular member including a protective sleeve coupled to the end portions of the first and second tubular member.

[0080] Fig. 17b is a fragmentary cross-sectional illustration of the radial expansion and plastic deformation of the threaded portions of the first and second tubular members using an adjustable expansion cone.

[0081] Fig. 17c is an enlarged fragmentary cross-sectional illustration of the threaded portions of the first and second tubular members and the protective sleeve prior to the radial expansion and plastic deformation of the threaded portions.

[0082] Fig. 17d is an enlarged fragmentary cross-sectional illustration of the threaded portions of the first and second tubular members and the protective sleeve after the radial expansion and plastic deformation of the threaded portions.

[0083] Fig. 18a is a fragmentary cross-sectional illustration of the coupling of an internally threaded end portion of a first tubular member to an externally threaded end portion of a second tubular member including a protective sleeve coupled to the end portions of the first and second tubular member.

[0084] Fig. 18b is a fragmentary cross-sectional illustration of the radial expansion and plastic deformation of the threaded portions of the first and second tubular members using a rotary expansion tool.

[0085] Fig. 19 is an exemplary embodiment of a method of providing a fluid tight seal in the junction between a pair of adjacent tubular members.

[0086] Fig. 20 is an exemplary embodiment of a method of transmitting energy through a pair of radially expanded adjacent tubular members including a protecting sleeve.

[0087] Fig. 21 is a fragmentary cross sectional illustration of an embodiment of a dual well completion system.

Detailed Description of the Illustrative Embodiments

[0088] Referring to Fig. 1a, a first tubular member 10 includes an internally threaded connection 12 at an end portion 14. As illustrated in Fig. 1b, a first end of a tubular sleeve 16 that includes an internal flange 18 and tapered portions, 20 and 22, at opposite ends is then mounted upon and receives the end portion 14 of the first tubular member 10. In an exemplary embodiment, the end portion 14 of the first tubular member 10 abuts one side of the internal flange 18 of the tubular sleeve 16, and the internal diameter of the internal flange of the tubular sleeve is substantially equal to or greater than the maximum internal diameter of the internally threaded connection 12 of the end portion of the first tubular member. As illustrated in Fig. 1c, an externally threaded connection 24 of an end portion 26 of a second tubular member 28 having an annular recess 30 is then positioned within the tubular sleeve 16 and threadably coupled to the internally threaded connection 12 of the end portion 14 of the first

tubular member 10. In an exemplary embodiment, the internal flange 18 of the tubular sleeve 16 mates with and is received within the annular recess 30 of the end portion 26 of the second tubular member 28. Thus, the tubular sleeve 16 is coupled to and surrounds the external surfaces of the first and second tubular members, 10 and 28.

[0089] In an exemplary embodiment, the internally threaded connection 12 of the end portion 14 of the first tubular member 10 is a box connection, and the externally threaded connection 24 of the end portion 26 of the second tubular member 28 is a pin connection. In an exemplary embodiment, the internal diameter of the tubular sleeve 16 is at least approximately .020" greater than the outside diameters of the first and second tubular members, 10 and 28. In this manner, during the threaded coupling of the first and second tubular members, 10 and 28, fluidic materials within the first and second tubular members may be vented from the tubular members.

[0090] In an exemplary embodiment, as illustrated in Figs. 1d and 1e, the first and second tubular members, 10 and 28, and the tubular sleeve 16 may then be positioned within another structure 32 such as, for example, a wellbore, and radially expanded and plastically deformed, for example, by moving an expansion cone 34 through the interiors of the first and second tubular members. The tapered portions, 20 and 22, of the tubular sleeve 16 facilitate the insertion and movement of the first and second tubular members within and through the structure 32, and the movement of the expansion cone 34 through the interiors of the first and second tubular members, 10 and 28, may be from top to bottom or from bottom to top.

[0091] In an exemplary embodiment, during the radial expansion and plastic deformation of the first and second tubular members, 10 and 28, the tubular sleeve 16 is also radially expanded and plastically deformed. In an exemplary embodiment, as a result, the tubular sleeve 16 may be maintained in circumferential tension and the end portions, 14 and 26, of the first and second tubular members, 10 and 28, may be maintained in circumferential compression.

[0092] In several exemplary embodiments, the first and second tubular members, 10 and 28, are radially expanded and plastically deformed using the expansion cone 34 in a conventional manner and/or using one or more of the methods and apparatus disclosed in one or more of the following: (1) U.S. patent application serial no. 09/454,139, attorney docket no. 25791.03.02, filed on 12/3/1999, (2) U.S. patent application serial no. 09/510,913, attorney docket no. 25791.7.02, filed on 2/23/2000, (3) U.S. patent application serial no. 09/502,350, attorney docket no. 25791.8.02, filed on 2/10/2000, (4) U.S. patent application serial no. 09/440,338, attorney docket no. 25791.9.02, filed on 11/15/1999, (5) U.S. patent application serial no. 09/523,460, attorney docket no. 25791.11.02, filed on 3/10/2000, (6) U.S. patent application serial no. 09/512,895, attorney docket no. 25791.12.02, filed on 2/24/2000, (7) U.S. patent application serial no. 09/511,941, attorney docket no. 25791.16.02, filed on 2/24/2000, (8) U.S. patent application serial no. 09/588,946, attorney docket no. 25791.17.02, filed on 6/7/2000, (9) U.S. patent application serial no. 09/559,122, attorney docket no. 25791.23.02, filed on 4/26/2000,

(10) PCT patent application serial no. PCT/US00/18635, attorney docket no. 25791.25.02, filed on 7/9/2000, (11) U.S. provisional patent application serial no. 60/162,671, attorney docket no. 25791.27, filed on 11/1/1999, (12) U.S. provisional patent application serial no. 60/154,047, attorney docket no. 25791.29, filed on 9/16/1999, (13) U.S. provisional patent application serial no. 60/159,082, attorney docket no. 25791.34, filed on 10/12/1999, (14) U.S. provisional patent application serial no. 60/159,039, attorney docket no. 25791.36, filed on 10/12/1999, (15) U.S. provisional patent application serial no. 60/159,033, attorney docket no. 25791.37, filed on 10/12/1999, (16) U.S. provisional patent application serial no. 60/212,359, attorney docket no. 25791.38, filed on 6/19/2000, (17) U.S. provisional patent application serial no. 60/165,228, attorney docket no. 25791.39, filed on 11/12/1999, (18) U.S. provisional patent application serial no. 60/221,443, attorney docket no. 25791.45, filed on 7/28/2000, (19) U.S. provisional patent application serial no. 60/221,645, attorney docket no. 25791.46, filed on 7/28/2000, (20) U.S. provisional patent application serial no. 60/233,638, attorney docket no. 25791.47, filed on 9/18/2000, (21) U.S. provisional patent application serial no. 60/237,334, attorney docket no. 25791.48, filed on 10/2/2000, (22) U.S. provisional patent application serial no. 60/270,007, attorney docket no. 25791.50, filed on 2/20/2001, (23) U.S. provisional patent application serial no. 60/262,434, attorney docket no. 25791.51, filed on 1/17/2001, (24) U.S. provisional patent application serial no. 60/259,486, attorney docket no. 25791.52, filed on 1/3/2001, (25) U.S. provisional patent application serial no. 60/303,740, attorney docket no. 25791.61, filed on 7/6/2001, (26) U.S. provisional patent application serial no. 60/313,453, attorney docket no. 25791.59, filed on 8/20/2001, (27) U.S. provisional patent application serial no. 60/317,985, attorney docket no. 25791.67, filed on 9/6/2001, (28) U.S. provisional patent application serial no. 60/3318,386, attorney docket no. 25791.67.02, filed on 9/10/2001, (29) U.S. utility patent application serial no. 09/969,922, attorney docket no. 25791.69, filed on 10/3/2001, (30) U.S. utility patent application serial no. 10/016,467, attorney docket no. 25791.70, filed on 12/10/2001; (31) U.S. provisional patent application serial no. 60/343,674, attorney docket no. 25791.68, filed on 12/27/2001; (32) U.S. provisional patent application serial no. 60/346,309, attorney docket no. 25791.92, filed on 1/7/2002; (33) U.S. provisional patent application serial no. 60/372,048, attorney docket no. 25791.93, filed on 4/12/2002; (34) U.S. provisional patent application serial no. 60/380,147, attorney docket no. 25791.104, filed on 5/6/2002; (35) U.S. provisional patent application serial no. 60/387,486, attorney docket no. 25791.107, filed on 6/10/2002; (36) U.S. provisional patent application serial no. 60/387,961, attorney docket no. 25791.108, filed on 6/12/2002; (37) U.S. provisional patent application serial no. 60/391,703, attorney docket no. 25791.90, filed on 6/26/2002; and (38) U.S. provisional patent application serial no. 60/397,284, attorney docket no. 25791.106, filed on 7/19/2002, the disclosures of which are incorporated herein by reference.

[0093] In several alternative embodiments, the first and second tubular members, 10 and 28, are radially expanded and plastically deformed using other conventional methods for radially expanding

and plastically deforming tubular members such as, for example, internal pressurization and/or roller expansion devices such as, for example, that disclosed in U.S. patent application publication no. US 2001/0045284 A1, the disclosure of which is incorporated herein by reference.

[0094] The use of the tubular sleeve 16 during (a) the coupling of the first tubular member 10 to the second tubular member 28, (b) the placement of the first and second tubular members in the structure 32, and (c) the radial expansion and plastic deformation of the first and second tubular members provides a number of significant benefits. For example, the tubular sleeve 16 protects the exterior surfaces of the end portions, 14 and 26, of the first and second tubular members, 10 and 28, during handling and insertion of the tubular members within the structure 32. In this manner, damage to the exterior surfaces of the end portions, 14 and 26, of the first and second tubular member, 10 and 28, are prevented that could result in stress concentrations that could result in a catastrophic failure during subsequent radial expansion operations. Furthermore, the tubular sleeve 16 provides an alignment guide that facilitates the insertion and threaded coupling of the second tubular member 28 to the first tubular member 10. In this manner, misalignment that could result in damage to the threaded connections, 12 and 24, of the first and second tubular members, 10 and 28, may be avoided. In addition, during the relative rotation of the second tubular member with respect to the first tubular member, required during the threaded coupling of the first and second tubular members, the tubular sleeve 16 provides an indication of to what degree the first and second tubular members are threadably coupled. For example, if the tubular sleeve 16 can be easily rotated, that would indicate that the first and second tubular members, 10 and 28, are not fully threadably coupled and in intimate contact with the internal flange 18 of the tubular sleeve. Furthermore, the tubular sleeve 16 may prevent crack propagation during the radial expansion and plastic deformation of the first and second tubular members, 10 and 28. In this manner, failure modes such as, for example, longitudinal cracks in the end portions, 14 and 26, of the first and second tubular members may be limited in severity or eliminated all together. In addition, after completing the radial expansion and plastic deformation of the first and second tubular members, 10 and 28, the tubular sleeve 16 may provide a fluid tight metal-to-metal seal between interior surface of the tubular sleeve and the exterior surfaces of the end portions, 14 and 26, of the first and second tubular members. In this manner, fluidic materials are prevented from passing through the threaded connections, 12 and 24, of the first and second tubular members, 10 and 28, into the annulus between the first and second tubular members and the structure 32. Furthermore, because, following the radial expansion and plastic deformation of the first and second tubular members, 10 and 28, the tubular sleeve 16 may be maintained in circumferential tension and the end portions, 14 and 26, of the first and second tubular members, 10 and 28, may be maintained in circumferential compression, axial loads and/or torque loads may be transmitted through the tubular sleeve. In addition, the tubular sleeve 16 may also increase the collapse strength of the end portions, 14 and 26, of the first and second tubular members, 10 and 28.

[0095] Referring to Figs. 2a and 2b, in an alternative embodiment, a tubular sleeve 110 having an internal flange 112 and a tapered portion 114 is coupled to the first and second tubular members, 10 and 28. In particular, the tubular sleeve 110 receives and mates with the end portion 14 of the first tubular member 10, and the internal flange 112 of the tubular sleeve is received within the annular recess 30 of the second tubular member 28 proximate the end of the first tubular member. In this manner, the tubular sleeve 110 is coupled to the end portions, 14 and 26, of the first and second tubular members, 10 and 28, and the tubular sleeve covers the end portion 14 of the first tubular member 10.

[0096] In an exemplary embodiment, the first and second tubular members, 10 and 28, and the tubular sleeve 110 may then be positioned within the structure 32 and radially expanded and plastically deformed, for example, by moving an expansion cone 34 through the interiors of the first and second tubular members. In an exemplary embodiment, following the radial expansion and plastic deformation of the first and second tubular members, 10 and 28, the tubular sleeve 110 may be maintained in circumferential tension and the end portions, 14 and 26, of the first and second tubular members, 10 and 28, may be maintained in circumferential compression.

[0097] The use of the tubular sleeve 110 during (a) the coupling of the first tubular member 10 to the second tubular member 28, (b) the placement of the first and second tubular members in the structure 32, and (c) the radial expansion and plastic deformation of the first and second tubular members provides a number of significant benefits. For example, the tubular sleeve 110 protects the exterior surface of the end portion 14 of the first tubular member 10 during handling and insertion of the tubular members within the structure 32. In this manner, damage to the exterior surfaces of the end portion 14 of the first tubular member 10 is prevented that could result in stress concentrations that could result in a catastrophic failure during subsequent radial expansion operations. In addition, during the relative rotation of the second tubular member with respect to the first tubular member, required during the threaded coupling of the first and second tubular members, the tubular sleeve 110 provides an indication of to what degree the first and second tubular members are threadably coupled. For example, if the tubular sleeve 110 can be easily rotated, that would indicate that the first and second tubular members, 10 and 28, are not fully threadably coupled and in intimate contact with the internal flange 112 of the tubular sleeve. Furthermore, the tubular sleeve 110 may prevent crack propagation during the radial expansion and plastic deformation of the first and second tubular members, 10 and 28. In this manner, failure modes such as, for example, longitudinal cracks in the end portions, 14 and 26, of the first and second tubular members may be limited in severity or eliminated all together. In addition, after completing the radial expansion and plastic deformation of the first and second tubular members, 10 and 28, the tubular sleeve 110 may provide a fluid tight metal-to-metal seal between interior surface of the tubular sleeve and the exterior surface of the end portion 14 of the first tubular member. In this manner, fluidic materials are prevented from passing through the threaded connections, 12 and 24, of the first and second tubular members, 10 and 28, into the annulus between

the first and second tubular members and the structure 32. Furthermore, because, following the radial expansion and plastic deformation of the first and second tubular members, 10 and 28, the tubular sleeve 110 may be maintained in circumferential tension and the end portions, 14 and 26, of the first and second tubular members, 10 and 28, may be maintained in circumferential compression, axial loads and/or torque loads may be transmitted through the tubular sleeve.

[0098] Referring to Figs. 3a and 3b, in an alternative embodiment, a tubular sleeve 210 having an internal flange 212, tapered portions, 214 and 216, at opposite ends, and annular sealing members, 218 and 220, positioned on opposite sides of the internal flange, is coupled to the first and second tubular members, 10 and 28. In particular, the tubular sleeve 210 receives and mates with the end portions, 14 and 26, of the first and second tubular members, 10 and 28, and the internal flange 212 of the tubular sleeve is received within the annular recess 30 of the second tubular member 28 proximate the end of the first tubular member. Furthermore, the sealing members, 218 and 220, of the tubular sleeve 210 engage and fluidically seal the interface between the tubular sleeve and the end portions, 14 and 26, of the first and second tubular members, 10 and 28. In this manner, the tubular sleeve 210 is coupled to the end portions, 14 and 26, of the first and second tubular members, 10 and 28, and the tubular sleeve covers the end portions, 14 and 26, of the first and second tubular members, 10 and 28.

[0099] In an exemplary embodiment, the first and second tubular members, 10 and 28, and the tubular sleeve 210 may then be positioned within the structure 32 and radially expanded and plastically deformed, for example, by moving an expansion cone 34 through the interiors of the first and second tubular members. In an exemplary embodiment, following the radial expansion and plastic deformation of the first and second tubular members, 10 and 28, the tubular sleeve 210 may be maintained in circumferential tension and the end portions, 14 and 26, of the first and second tubular members, 10 and 28, may be maintained in circumferential compression.

[00100] The use of the tubular sleeve 210 during (a) the coupling of the first tubular member 10 to the second tubular member 28, (b) the placement of the first and second tubular members in the structure 32, and (c) the radial expansion and plastic deformation of the first and second tubular members provides a number of significant benefits. For example, the tubular sleeve 210 protects the exterior surfaces of the end portions, 14 and 26, of the first and second tubular members, 10 and 28, during handling and insertion of the tubular members within the structure 32. In this manner, damage to the exterior surfaces of the end portions, 14 and 26, of the first and second tubular members, 10 and 28, is prevented that could result in stress concentrations that could result in a catastrophic failure during subsequent radial expansion operations. In addition, during the relative rotation of the second tubular member with respect to the first tubular member, required during the threaded coupling of the first and second tubular members, the tubular sleeve 210 provides an indication of to what degree the first and second tubular members are threadably coupled. For example, if the tubular sleeve 210 can be easily rotated, that would indicate that the first and second tubular members, 10 and 28, are not fully

threadably coupled and in intimate contact with the internal flange 212 of the tubular sleeve. Furthermore, the tubular sleeve 210 may prevent crack propagation during the radial expansion and plastic deformation of the first and second tubular members, 10 and 28. In this manner, failure modes such as, for example, longitudinal cracks in the end portions, 14 and 26, of the first and second tubular members, 10 and 28, may be limited in severity or eliminated all together. In addition, after completing the radial expansion and plastic deformation of the first and second tubular members, 10 and 28, the tubular sleeve 210 may provide a fluid tight metal-to-metal seal between interior surface of the tubular sleeve and the exterior surfaces of the end portions, 14 and 26, of the first and second tubular members. In this manner, fluidic materials are prevented from passing through the threaded connections, 12 and 24, of the first and second tubular members, 10 and 28, into the annulus between the first and second tubular members and the structure 32. Furthermore, because, following the radial expansion and plastic deformation of the first and second tubular members, 10 and 28, the tubular sleeve 210 may be maintained in circumferential tension and the end portions, 14 and 26, of the first and second tubular members, 10 and 28, may be maintained in circumferential compression, axial loads and/or torque loads may be transmitted through the tubular sleeve. In addition, the tubular sleeve 210 may also increase the collapse strength of the end portions, 14 and 26, of the first and second tubular members, 10 and 28.

[00101] Referring to Figs. 4a and 4b, in an alternative embodiment, a tubular sleeve 310 having an internal flange 312, tapered portions, 314 and 316, at opposite ends, and an annular sealing member 318 positioned on the exterior surface of the tubular sleeve, is coupled to the first and second tubular members, 10 and 28. In particular, the tubular sleeve 310 receives and mates with the end portions, 14 and 26, of the first and second tubular members, 10 and 28, and the internal flange 312 of the tubular sleeve is received within the annular recess 30 of the second tubular member 28 proximate the end of the first tubular member. In this manner, the tubular sleeve 310 is coupled to the end portions, 14 and 26, of the first and second tubular members, 10 and 28, and the tubular sleeve covers the end portions, 14 and 26, of the first and second tubular members, 10 and 28.

[00102] In an exemplary embodiment, the first and second tubular members, 10 and 28, and the tubular sleeve 310 may then be positioned within the structure 32 and radially expanded and plastically deformed, for example, by moving an expansion cone 34 through the interiors of the first and second tubular members. In an exemplary embodiment, following the radial expansion and plastic deformation of the first and second tubular members, 10 and 28, the tubular sleeve 310 may be maintained in circumferential tension and the end portions, 14 and 26, of the first and second tubular members, 10 and 28, may be maintained in circumferential compression. Furthermore, in an exemplary embodiment, following the radial expansion and plastic deformation of the first and second tubular members, 10 and 28, the annular sealing member 318 circumferentially engages the interior surface of the structure 32 thereby preventing the passage of fluidic materials through the annulus

between the tubular sleeve 310 and the structure. In this manner, the tubular sleeve 310 may provide an expandable packer element.

[00103] The use of the tubular sleeve 310 during (a) the coupling of the first tubular member 10 to the second tubular member 28, (b) the placement of the first and second tubular members in the structure 32, and (c) the radial expansion and plastic deformation of the first and second tubular members provides a number of significant benefits. For example, the tubular sleeve 310 protects the exterior surfaces of the end portions, 14 and 26, of the first and second tubular members, 10 and 28, during handling and insertion of the tubular members within the structure 32. In this manner, damage to the exterior surfaces of the end portions, 14 and 26, of the first and second tubular members, 10 and 28, is prevented that could result in stress concentrations that could result in a catastrophic failure during subsequent radial expansion operations. In addition, during the relative rotation of the second tubular member with respect to the first tubular member, required during the threaded coupling of the first and second tubular members, the tubular sleeve 310 provides an indication of to what degree the first and second tubular members are threadably coupled. For example, if the tubular sleeve 310 can be easily rotated, that would indicate that the first and second tubular members, 10 and 28, are not fully threadably coupled and in intimate contact with the internal flange 312 of the tubular sleeve.

Furthermore, the tubular sleeve 310 may prevent crack propagation during the radial expansion and plastic deformation of the first and second tubular members, 10 and 28. In this manner, failure modes such as, for example, longitudinal cracks in the end portions, 14 and 26, of the first and second tubular members, 10 and 28, may be limited in severity or eliminated all together. In addition, after completing the radial expansion and plastic deformation of the first and second tubular members, 10 and 28, the tubular sleeve 310 may provide a fluid tight metal-to-metal seal between interior surface of the tubular sleeve and the exterior surfaces of the end portions, 14 and 26, of the first and second tubular members. In this manner, fluidic materials are prevented from passing through the threaded connections, 12 and 24, of the first and second tubular members, 10 and 28, into the annulus between the first and second tubular members and the structure 32. Furthermore, because, following the radial expansion and plastic deformation of the first and second tubular members, 10 and 28, the tubular sleeve 310 may be maintained in circumferential tension and the end portions, 14 and 26, of the first and second tubular members, 10 and 28, may be maintained in circumferential compression, axial loads and/or torque loads may be transmitted through the tubular sleeve. In addition, because, following the radial expansion and plastic deformation of the first and second tubular members, 10 and 28, the annular sealing member 318 may circumferentially engage the interior surface of the structure 32, the tubular sleeve 310 may provide an expandable packer element. In addition, the tubular sleeve 318 may also increase the collapse strength of the end portions, 14 and 26, of the first and second tubular members, 10 and 28.

[00104] Referring to Figs. 5a and 5b, in an alternative embodiment, a non-metallic tubular sleeve

410 having an internal flange 412, and tapered portions, 414 and 416, at opposite ends, is coupled to the first and second tubular members, 10 and 28. In particular, the tubular sleeve 410 receives and mates with the end portions, 14 and 26, of the first and second tubular members, 10 and 28, and the internal flange 412 of the tubular sleeve is received within the annular recess 30 of the second tubular member 28 proximate the end of the first tubular member. In this manner, the tubular sleeve 410 is coupled to the end portions, 14 and 26, of the first and second tubular members, 10 and 28, and the tubular sleeve covers the end portions, 14 and 26, of the first and second tubular members, 10 and 28.

[00105] In several exemplary embodiments, the tubular sleeve 410 may be plastic, ceramic, elastomeric, composite and/or a frangible material.

[00106] In an exemplary embodiment, the first and second tubular members, 10 and 28, and the tubular sleeve 410 may then be positioned within the structure 32 and radially expanded and plastically deformed, for example, by moving an expansion cone 34 through the interiors of the first and second tubular members. In an exemplary embodiment, following the radial expansion and plastic deformation of the first and second tubular members, 10 and 28, the tubular sleeve 410 may be maintained in circumferential tension and the end portions, 14 and 26, of the first and second tubular members, 10 and 28, may be maintained in circumferential compression. Furthermore, in an exemplary embodiment, during the radial expansion and plastic deformation of the first and second tubular members, 10 and 28, the tubular sleeve 310 may be broken off of the first and second tubular members.

[00107] The use of the tubular sleeve 410 during (a) the coupling of the first tubular member 10 to the second tubular member 28, (b) the placement of the first and second tubular members in the structure 32, and (c) the radial expansion and plastic deformation of the first and second tubular members provides a number of significant benefits. For example, the tubular sleeve 410 protects the exterior surfaces of the end portions, 14 and 26, of the first and second tubular members, 10 and 28, during handling and insertion of the tubular members within the structure 32. In this manner, damage to the exterior surfaces of the end portions, 14 and 26, of the first and second tubular members, 10 and 28, is prevented that could result in stress concentrations that could result in a catastrophic failure during subsequent radial expansion operations. In addition, during the relative rotation of the second tubular member with respect to the first tubular member, required during the threaded coupling of the first and second tubular members, the tubular sleeve 410 provides an indication of to what degree the first and second tubular members are threadably coupled. For example, if the tubular sleeve 410 can be easily rotated, that would indicate that the first and second tubular members, 10 and 28, are not fully threadably coupled and in intimate contact with the internal flange 412 of the tubular sleeve.

Furthermore, the tubular sleeve 410 may prevent crack propagation during the radial expansion and plastic deformation of the first and second tubular members, 10 and 28. In this manner, failure modes such as, for example, longitudinal cracks in the end portions, 14 and 26, of the first and second tubular

members, 10 and 28, may be limited in severity or eliminated all together. In addition, after completing the radial expansion and plastic deformation of the first and second tubular members, 10 and 28, the tubular sleeve 410 may provide a fluid tight metal-to-metal seal between interior surface of the tubular sleeve and the exterior surfaces of the end portions, 14 and 26, of the first and second tubular members. In this manner, fluidic materials are prevented from passing through the threaded connections, 12 and 24, of the first and second tubular members, 10 and 28, into the annulus between the first and second tubular members and the structure 32. Furthermore, because, following the radial expansion and plastic deformation of the first and second tubular members, 10 and 28, the tubular sleeve 410 may be maintained in circumferential tension and the end portions, 14 and 26, of the first and second tubular members, 10 and 28, may be maintained in circumferential compression, axial loads and/or torque loads may be transmitted through the tubular sleeve. In addition, because, during the radial expansion and plastic deformation of the first and second tubular members, 10 and 28, the tubular sleeve 410 may be broken off of the first and second tubular members, the final outside diameter of the first and second tubular members may more closely match the inside diameter of the structure 32. In addition, the tubular sleeve 410 may also increase the collapse strength of the end portions, 14 and 26, of the first and second tubular members, 10 and 28.

[00108] Referring to Fig. 6a, in an exemplary embodiment, a tubular sleeve 510 includes an internal flange 512, tapered portions, 514 and 516, at opposite ends, and defines one or more axial slots 518. In an exemplary embodiment, during the radial expansion and plastic deformation of the first and second tubular members, 10 and 28, the axial slots 518 reduce the required radial expansion forces.

[00109] Referring to Fig. 6b, in an exemplary embodiment, a tubular sleeve 610 includes an internal flange 612, tapered portions, 614 and 616, at opposite ends, and defines one or more offset axial slots 618. In an exemplary embodiment, during the radial expansion and plastic deformation of the first and second tubular members, 10 and 28, the axial slots 618 reduce the required radial expansion forces.

[00110] Referring to Fig. 6c, in an exemplary embodiment, a tubular sleeve 710 includes an internal flange 712, tapered portions, 714 and 716, at opposite ends, and defines one or more radial openings 718. In an exemplary embodiment, during the radial expansion and plastic deformation of the first and second tubular members, 10 and 28, the radial openings 718 reduce the required radial expansion forces.

[00111] Referring to Fig. 6d, in an exemplary embodiment, a tubular sleeve 810 includes an internal flange 812, tapered portions, 814 and 816, at opposite ends, and defines one or more axial slots 818 that extend from the ends of the tubular sleeve. In an exemplary embodiment, during the radial expansion and plastic deformation of the first and second tubular members, 10 and 28, the axial slots 818 reduce the required radial expansion forces.

[00112] Referring to Fig. 7a, a first tubular member 910 includes an internally threaded connection

912 at an end portion 914 and a recessed portion 916 having a reduced outside diameter. As illustrated in Fig. 7b, a first end of a tubular sleeve 918 that includes annular sealing members, 920 and 922, at opposite ends, tapered portions, 924 and 926, at one end, and tapered portions, 928 and 930, at another end is then mounted upon and receives the end portion 914 of the first tubular member 910. In an exemplary embodiment, a resilient retaining ring 930 is positioned between the lower end of the tubular sleeve 918 and the recessed portion 916 of the first tubular member 910 in order to couple the tubular sleeve to the first tubular member. In an exemplary embodiment, the resilient retaining ring 930 is a split ring having a toothed surface in order to lock the tubular sleeve 918 in place.

[00113] As illustrated in Fig. 7c, an externally threaded connection 934 of an end portion 936 of a second tubular member 938 having a recessed portion 940 having a reduced outside diameter is then positioned within the tubular sleeve 918 and threadably coupled to the internally threaded connection 912 of the end portion 914 of the first tubular member 910. In an exemplary embodiment, a resilient retaining ring 942 is positioned between the upper end of the tubular sleeve 918 and the recessed portion 940 of the second tubular member 938 in order to couple the tubular sleeve to the second tubular member. In an exemplary embodiment, the resilient retaining ring 942 is a split ring having a toothed surface in order to lock the tubular sleeve 918 in place.

[00114] In an exemplary embodiment, the internally threaded connection 912 of the end portion 914 of the first tubular member 910 is a box connection, and the externally threaded connection 934 of the end portion 936 of the second tubular member 938 is a pin connection. In an exemplary embodiment, the internal diameter of the tubular sleeve 918 is at least approximately .020" greater than the outside diameters of the end portions, 914 and 936, of the first and second tubular members, 910 and 938. In this manner, during the threaded coupling of the first and second tubular members, 910 and 938, fluidic materials within the first and second tubular members may be vented from the tubular members.

[00115] In an exemplary embodiment, as illustrated in Figs. 7d and 7e, the first and second tubular members, 910 and 938, and the tubular sleeve 918 may then be positioned within another structure 32 such as, for example, a wellbore, and radially expanded and plastically deformed, for example, by moving an expansion cone 34 through the interiors of the first and second tubular members. The tapered portions, 924 and 928, of the tubular sleeve 918 facilitate the insertion and movement of the first and second tubular members within and through the structure 32, and the movement of the expansion cone 34 through the interiors of the first and second tubular members, 910 and 938, may be from top to bottom or from bottom to top.

[00116] In an exemplary embodiment, during the radial expansion and plastic deformation of the first and second tubular members, 910 and 938, the tubular sleeve 918 is also radially expanded and plastically deformed. In an exemplary embodiment, as a result, the tubular sleeve 918 may be maintained in circumferential tension and the end portions, 914 and 936, of the first and second tubular

members, 910 and 938, may be maintained in circumferential compression.

[00117] The use of the tubular sleeve 918 during (a) the coupling of the first tubular member 910 to the second tubular member 938, (b) the placement of the first and second tubular members in the structure 32, and (c) the radial expansion and plastic deformation of the first and second tubular members provides a number of significant benefits. For example, the tubular sleeve 918 protects the exterior surfaces of the end portions, 914 and 936, of the first and second tubular members, 910 and 938, during handling and insertion of the tubular members within the structure 32. In this manner, damage to the exterior surfaces of the end portions, 914 and 936, of the first and second tubular member, 910 and 938, are prevented that could result in stress concentrations that could result in a catastrophic failure during subsequent radial expansion operations. Furthermore, the tubular sleeve 918 provides an alignment guide that facilitates the insertion and threaded coupling of the second tubular member 938 to the first tubular member 910. In this manner, misalignment that could result in damage to the threaded connections, 912 and 934, of the first and second tubular members, 910 and 938, may be avoided. Furthermore, the tubular sleeve 918 may prevent crack propagation during the radial expansion and plastic deformation of the first and second tubular members, 910 and 938. In this manner, failure modes such as, for example, longitudinal cracks in the end portions, 914 and 936, of the first and second tubular members may be limited in severity or eliminated all together. In addition, after completing the radial expansion and plastic deformation of the first and second tubular members, 910 and 938, the tubular sleeve 918 may provide a fluid tight metal-to-metal seal between interior surface of the tubular sleeve and the exterior surfaces of the end portions, 914 and 936, of the first and second tubular members. In this manner, fluidic materials are prevented from passing through the threaded connections, 912 and 934, of the first and second tubular members, 910 and 938, into the annulus between the first and second tubular members and the structure 32. Furthermore, because, following the radial expansion and plastic deformation of the first and second tubular members, 910 and 938, the tubular sleeve 918 may be maintained in circumferential tension and the end portions, 914 and 936, of the first and second tubular members, 910 and 938, may be maintained in circumferential compression, axial loads and/or torque loads may be transmitted through the tubular sleeve. In addition, the annular sealing members, 920 and 922, of the tubular sleeve 918 may provide a fluid tight seal between the tubular sleeve and the end portions, 914 and 936, of the first and second tubular members, 910 and 938. Furthermore, the tubular sleeve 918 may also increase the collapse strength of the end portions, 914 and 936, of the first and second tubular members, 910 and 938.

[00118] Referring to Fig. 8a, a first tubular member 1010 includes an internally threaded connection 1012 at an end portion 1014 and a recessed portion 1016 having a reduced outside diameter. As illustrated in Fig. 8b, a first end of a tubular sleeve 1018 that includes annular sealing members, 1020 and 1022, at opposite ends, tapered portions, 1024 and 1026, at one end, and tapered portions, 1028 and 1030, at another end is then mounted upon and receives the end portion 1014 of the

first tubular member 1010. In an exemplary embodiment, as illustrated in Fig. 8c, the end of the tubular sleeve 1018 is then crimped onto the recessed portion 1016 of the first tubular member 1010 in order to couple the tubular sleeve to the first tubular member.

[00119] As illustrated in Fig. 8d, an externally threaded connection 1032 of an end portion 1034 of a second tubular member 1036 having a recessed portion 1038 having a reduced external diameter is then positioned within the tubular sleeve 1018 and threadably coupled to the internally threaded connection 1012 of the end portion 1014 of the first tubular member 1010. In an exemplary embodiment, as illustrated in Fig. 8e, the other end of the tubular sleeve 1018 is then crimped into the recessed portion 1038 of the second tubular member 1036 in order to couple the tubular sleeve to the second tubular member.

[00120] In an exemplary embodiment, the internally threaded connection 1012 of the end portion 1014 of the first tubular member 1010 is a box connection, and the externally threaded connection 1032 of the end portion 1034 of the second tubular member 1036 is a pin connection. In an exemplary embodiment, the internal diameter of the tubular sleeve 1018 is at least approximately .020" greater than the outside diameters of the end portions, 1014 and 1034, of the first and second tubular members, 1010 and 1036. In this manner, during the threaded coupling of the first and second tubular members, 1010 and 1036, fluidic materials within the first and second tubular members may be vented from the tubular members.

[00121] In an exemplary embodiment, as illustrated in Figs. 8f and 8g, the first and second tubular members, 1010 and 1036, and the tubular sleeve 1018 may then be positioned within another structure 32 such as, for example, a wellbore, and radially expanded and plastically deformed, for example, by moving an expansion cone 34 through the interiors of the first and second tubular members. The movement of the expansion cone 34 through the interiors of the first and second tubular members, 1010 and 1036, may be from top to bottom or from bottom to top.

[00122] In an exemplary embodiment, during the radial expansion and plastic deformation of the first and second tubular members, 1010 and 1036, the tubular sleeve 1018 is also radially expanded and plastically deformed. In an exemplary embodiment, as a result, the tubular sleeve 1018 may be maintained in circumferential tension and the end portions, 1014 and 1034, of the first and second tubular members, 1010 and 1036, may be maintained in circumferential compression.

[00123] The use of the tubular sleeve 1018 during (a) the coupling of the first tubular member 1010 to the second tubular member 1036, (b) the placement of the first and second tubular members in the structure 32, and (c) the radial expansion and plastic deformation of the first and second tubular members provides a number of significant benefits. For example, the tubular sleeve 1018 protects the exterior surfaces of the end portions, 1014 and 1034, of the first and second tubular members, 1010 and 1036, during handling and insertion of the tubular members within the structure 32. In this manner, damage to the exterior surfaces of the end portions, 1014 and 1034, of the first and second

tubular members, 1010 and 1036, are prevented that could result in stress concentrations that could result in a catastrophic failure during subsequent radial expansion operations. Furthermore, the tubular sleeve 1018 provides an alignment guide that facilitates the insertion and threaded coupling of the second tubular member 1036 to the first tubular member 1010. In this manner, misalignment that could result in damage to the threaded connections, 1012 and 1032, of the first and second tubular members, 1010 and 1036, may be avoided. Furthermore, the tubular sleeve 1018 may prevent crack propagation during the radial expansion and plastic deformation of the first and second tubular members, 1010 and 1036. In this manner, failure modes such as, for example, longitudinal cracks in the end portions, 1014 and 1034, of the first and second tubular members may be limited in severity or eliminated all together. In addition, after completing the radial expansion and plastic deformation of the first and second tubular members, 1010 and 1036, the tubular sleeve 1018 may provide a fluid tight metal-to-metal seal between interior surface of the tubular sleeve and the exterior surfaces of the end portions, 1014 and 1034, of the first and second tubular members. In this manner, fluidic materials are prevented from passing through the threaded connections, 1012 and 1032, of the first and second tubular members, 1010 and 1036, into the annulus between the first and second tubular members and the structure 32. Furthermore, because, following the radial expansion and plastic deformation of the first and second tubular members, 1010 and 1036, the tubular sleeve 1018 may be maintained in circumferential tension and the end portions, 1014 and 1034, of the first and second tubular members, 1010 and 1036, may be maintained in circumferential compression, axial loads and/or torque loads may be transmitted through the tubular sleeve. In addition, the annular sealing members, 1020 and 1022, of the tubular sleeve 1018 may provide a fluid tight seal between the tubular sleeve and the end portions, 1014 and 1034, of the first and second tubular members, 1010 and 1036. Furthermore, the tubular sleeve 1018 may also increase the collapse strength of the end portions, 1014 and 1034, of the first and second tubular members, 1010 and 1036.

[00124] Referring to Fig. 9a, a first tubular member 1110 includes an internally threaded connection 1112 at an end portion 1114. As illustrated in Fig. 9b, a first end of a tubular sleeve 1116 having tapered portions, 1118 and 1120, at opposite ends, is then mounted upon and receives the end portion 1114 of the first tubular member 1110. In an exemplary embodiment, a toothed resilient retaining ring 1122 is then attached to first tubular member 1010 below the end of the tubular sleeve 1116 in order to couple the tubular sleeve to the first tubular member.

[00125] As illustrated in Fig. 9c, an externally threaded connection 1124 of an end portion 1126 of a second tubular member 1128 is then positioned within the tubular sleeve 1116 and threadably coupled to the internally threaded connection 1112 of the end portion 1114 of the first tubular member 1110. In an exemplary embodiment, a toothed resilient retaining ring 1130 is then attached to second tubular member 1128 above the end of the tubular sleeve 1116 in order to couple the tubular sleeve to the second tubular member.

[00126] In an exemplary embodiment, the internally threaded connection 1112 of the end portion 1114 of the first tubular member 1110 is a box connection, and the externally threaded connection 1124 of the end portion 1126 of the second tubular member 1128 is a pin connection. In an exemplary embodiment, the internal diameter of the tubular sleeve 1116 is at least approximately .020" greater than the outside diameters of the end portions, 1114 and 1126, of the first and second tubular members, 1110 and 1128. In this manner, during the threaded coupling of the first and second tubular members, 1110 and 1128, fluidic materials within the first and second tubular members may be vented from the tubular members.

[00127] In an exemplary embodiment, as illustrated in Figs. 9d and 9e, the first and second tubular members, 1110 and 1128, and the tubular sleeve 1116 may then be positioned within another structure 32 such as, for example, a wellbore, and radially expanded and plastically deformed, for example, by moving an expansion cone 34 through the interiors of the first and second tubular members. The movement of the expansion cone 34 through the interiors of the first and second tubular members, 1110 and 1128, may be from top to bottom or from bottom to top.

[00128] In an exemplary embodiment, during the radial expansion and plastic deformation of the first and second tubular members, 1110 and 1128, the tubular sleeve 1116 is also radially expanded and plastically deformed. In an exemplary embodiment, as a result, the tubular sleeve 1116 may be maintained in circumferential tension and the end portions, 1114 and 1126, of the first and second tubular members, 1110 and 1128, may be maintained in circumferential compression.

[00129] The use of the tubular sleeve 1116 during (a) the coupling of the first tubular member 1110 to the second tubular member 1128, (b) the placement of the first and second tubular members in the structure 32, and (c) the radial expansion and plastic deformation of the first and second tubular members provides a number of significant benefits. For example, the tubular sleeve 1116 protects the exterior surfaces of the end portions, 1114 and 1126, of the first and second tubular members, 1110 and 1128, during handling and insertion of the tubular members within the structure 32. In this manner, damage to the exterior surfaces of the end portions, 1114 and 1126, of the first and second tubular members, 1110 and 1128, are prevented that could result in stress concentrations that could result in a catastrophic failure during subsequent radial expansion operations. Furthermore, the tubular sleeve 1116 provides an alignment guide that facilitates the insertion and threaded coupling of the second tubular member 1128 to the first tubular member 1110. In this manner, misalignment that could result in damage to the threaded connections, 1112 and 1124, of the first and second tubular members, 1110 and 1128, may be avoided. Furthermore, the tubular sleeve 1116 may prevent crack propagation during the radial expansion and plastic deformation of the first and second tubular members, 1110 and 1128. In this manner, failure modes such as, for example, longitudinal cracks in the end portions, 1114 and 1126, of the first and second tubular members may be limited in severity or eliminated all together. In addition, after completing the radial expansion and plastic deformation of

the first and second tubular members, 1110 and 1128, the tubular sleeve 1116 may provide a fluid tight metal-to-metal seal between interior surface of the tubular sleeve and the exterior surfaces of the end portions, 1114 and 1128, of the first and second tubular members. In this manner, fluidic materials are prevented from passing through the threaded connections, 1112 and 1124, of the first and second tubular members, 1110 and 1128, into the annulus between the first and second tubular members and the structure 32. Furthermore, because, following the radial expansion and plastic deformation of the first and second tubular members, 1110 and 1128, the tubular sleeve 1116 may be maintained in circumferential tension and the end portions, 1114 and 1126, of the first and second tubular members, 1110 and 1128, may be maintained in circumferential compression, axial loads and/or torque loads may be transmitted through the tubular sleeve. In addition, the tubular sleeve 1116 may also increase the collapse strength of the end portions, 1114 and 1126, of the first and second tubular members.

[00130] Referring to Fig. 10a, a first tubular member 1210 includes an internally threaded connection 1212 at an end portion 1214. As illustrated in Fig. 10b, a first end of a tubular sleeve 1216 having tapered portions, 1218 and 1220, at one end and tapered portions, 1222 and 1224, at another end, is then mounted upon and receives the end portion 1114 of the first tubular member 1110. In an exemplary embodiment, a resilient elastomeric O-ring 1226 is then positioned on the first tubular member 1210 below the tapered portion 1224 of the tubular sleeve 1216 in order to couple the tubular sleeve to the first tubular member.

[00131] As illustrated in Fig. 10c, an externally threaded connection 1228 of an end portion 1230 of a second tubular member 1232 is then positioned within the tubular sleeve 1216 and threadably coupled to the internally threaded connection 1212 of the end portion 1214 of the first tubular member 1210. In an exemplary embodiment, a resilient elastomeric O-ring 1234 is then positioned on the second tubular member 1232 below the tapered portion 1220 of the tubular sleeve 1216 in order to couple the tubular sleeve to the first tubular member.

[00132] In an exemplary embodiment, the internally threaded connection 1212 of the end portion 1214 of the first tubular member 1210 is a box connection, and the externally threaded connection 1228 of the end portion 1230 of the second tubular member 1232 is a pin connection. In an exemplary embodiment, the internal diameter of the tubular sleeve 1216 is at least approximately .020" greater than the outside diameters of the end portions, 1214 and 1230, of the first and second tubular members, 1210 and 1232. In this manner, during the threaded coupling of the first and second tubular members, 1210 and 1232, fluidic materials within the first and second tubular members may be vented from the tubular members.

[00133] In an exemplary embodiment, as illustrated in Figs. 10d and 10e, the first and second tubular members, 1210 and 1232, and the tubular sleeve 1216 may then be positioned within another structure 32 such as, for example, a wellbore, and radially expanded and plastically deformed, for example, by moving an expansion cone 34 through the interiors of the first and second tubular

members. The movement of the expansion cone 34 through the interiors of the first and second tubular members, 1210 and 1232, may be from top to bottom or from bottom to top.

[00134] In an exemplary embodiment, during the radial expansion and plastic deformation of the first and second tubular members, 1210 and 1232, the tubular sleeve 1216 is also radially expanded and plastically deformed. In an exemplary embodiment, as a result, the tubular sleeve 1216 may be maintained in circumferential tension and the end portions, 1214 and 1230, of the first and second tubular members, 1210 and 1232, may be maintained in circumferential compression.

[00135] The use of the tubular sleeve 1216 during (a) the coupling of the first tubular member 1210 to the second tubular member 1232, (b) the placement of the first and second tubular members in the structure 32, and (c) the radial expansion and plastic deformation of the first and second tubular members provides a number of significant benefits. For example, the tubular sleeve 1216 protects the exterior surfaces of the end portions, 1214 and 1230, of the first and second tubular members, 1210 and 1232, during handling and insertion of the tubular members within the structure 32. In this manner, damage to the exterior surfaces of the end portions, 1214 and 1230, of the first and second tubular members, 1210 and 1232, are prevented that could result in stress concentrations that could result in a catastrophic failure during subsequent radial expansion operations. Furthermore, the tubular sleeve 1216 provides an alignment guide that facilitates the insertion and threaded coupling of the second tubular member 1232 to the first tubular member 1210. In this manner, misalignment that could result in damage to the threaded connections, 1212 and 1228, of the first and second tubular members, 1210 and 1232, may be avoided. Furthermore, the tubular sleeve 1216 may prevent crack propagation during the radial expansion and plastic deformation of the first and second tubular members, 1210 and 1232. In this manner, failure modes such as, for example, longitudinal cracks in the end portions, 1214 and 1230, of the first and second tubular members may be limited in severity or eliminated all together. In addition, after completing the radial expansion and plastic deformation of the first and second tubular members, 1210 and 1232, the tubular sleeve 1216 may provide a fluid tight metal-to-metal seal between interior surface of the tubular sleeve and the exterior surfaces of the end portions, 1214 and 1230, of the first and second tubular members. In this manner, fluidic materials are prevented from passing through the threaded connections, 1212 and 1228, of the first and second tubular members, 1210 and 1232, into the annulus between the first and second tubular members and the structure 32. Furthermore, because, following the radial expansion and plastic deformation of the first and second tubular members, 1210 and 1232, the tubular sleeve 1216 may be maintained in circumferential tension and the end portions, 1214 and 1230, of the first and second tubular members, 1210 and 1232, may be maintained in circumferential compression, axial loads and/or torque loads may be transmitted through the tubular sleeve. In addition, the tubular sleeve 1216 may also increase the collapse strength of the end portions, 1214 and 1230, of the first and second tubular members 1210 and 1232.

[00136] Referring to Fig. 11a, a first tubular member 1310 includes an internally threaded connection 1312 at an end portion 1314. As illustrated in Fig. 11b, a first end of a tubular sleeve 1316 having tapered portions, 1318 and 1320, at opposite ends is then mounted upon and receives the end portion 1314 of the first tubular member 1310. In an exemplary embodiment, an annular resilient retaining member 1322 is then positioned on the first tubular member 1310 below the bottom end of the tubular sleeve 1316 in order to couple the tubular sleeve to the first tubular member.

[00137] As illustrated in Fig. 11c, an externally threaded connection 1324 of an end portion 1326 of a second tubular member 1328 is then positioned within the tubular sleeve 1316 and threadably coupled to the internally threaded connection 1312 of the end portion 1314 of the first tubular member 1310. In an exemplary embodiment, an annular resilient retaining member 1330 is then positioned on the second tubular member 1328 above the top end of the tubular sleeve 1316 in order to couple the tubular sleeve to the second tubular member.

[00138] In an exemplary embodiment, the internally threaded connection 1312 of the end portion 1314 of the first tubular member 1310 is a box connection, and the externally threaded connection 1324 of the end portion 1326 of the second tubular member 1328 is a pin connection. In an exemplary embodiment, the internal diameter of the tubular sleeve 1316 is at least approximately .020" greater than the outside diameters of the end portions, 1314 and 1326, of the first and second tubular members, 1310 and 1328. In this manner, during the threaded coupling of the first and second tubular members, 1310 and 1328, fluidic materials within the first and second tubular members may be vented from the tubular members.

[00139] In an exemplary embodiment, as illustrated in Figs. 11d and 11e, the first and second tubular members, 1310 and 1328, and the tubular sleeve 1316 may then be positioned within another structure 32 such as, for example, a wellbore, and radially expanded and plastically deformed, for example, by moving an expansion cone 34 through the interiors of the first and second tubular members. The movement of the expansion cone 34 through the interiors of the first and second tubular members, 1310 and 1328, may be from top to bottom or from bottom to top.

[00140] In an exemplary embodiment, during the radial expansion and plastic deformation of the first and second tubular members, 1310 and 1328, the tubular sleeve 1316 is also radially expanded and plastically deformed. In an exemplary embodiment, as a result, the tubular sleeve 1316 may be maintained in circumferential tension and the end portions, 1314 and 1326, of the first and second tubular members, 1310 and 1328, may be maintained in circumferential compression.

[00141] The use of the tubular sleeve 1316 during (a) the coupling of the first tubular member 1310 to the second tubular member 1328, (b) the placement of the first and second tubular members in the structure 32, and (c) the radial expansion and plastic deformation of the first and second tubular members provides a number of significant benefits. For example, the tubular sleeve 1316 protects the exterior surfaces of the end portions, 1314 and 1326, of the first and second tubular members, 1310

and 1328, during handling and insertion of the tubular members within the structure 32. In this manner, damage to the exterior surfaces of the end portions, 1314 and 1326, of the first and second tubular members, 1310 and 1328, are prevented that could result in stress concentrations that could result in a catastrophic failure during subsequent radial expansion operations. Furthermore, the tubular sleeve 1316 provides an alignment guide that facilitates the insertion and threaded coupling of the second tubular member 1328 to the first tubular member 1310. In this manner, misalignment that could result in damage to the threaded connections, 1312 and 1324, of the first and second tubular members, 1310 and 1328, may be avoided. Furthermore, the tubular sleeve 1316 may prevent crack propagation during the radial expansion and plastic deformation of the first and second tubular members, 1310 and 1328. In this manner, failure modes such as, for example, longitudinal cracks in the end portions, 1314 and 1326, of the first and second tubular members may be limited in severity or eliminated all together. In addition, after completing the radial expansion and plastic deformation of the first and second tubular members, 1310 and 1328, the tubular sleeve 1316 may provide a fluid tight metal-to-metal seal between interior surface of the tubular sleeve and the exterior surfaces of the end portions, 1314 and 1326, of the first and second tubular members. In this manner, fluidic materials are prevented from passing through the threaded connections, 1312 and 1324, of the first and second tubular members, 1310 and 1328, into the annulus between the first and second tubular members and the structure 32. Furthermore, because, following the radial expansion and plastic deformation of the first and second tubular members, 1310 and 1328, the tubular sleeve 1316 may be maintained in circumferential tension and the end portions, 1314 and 1326, of the first and second tubular members, 1310 and 1328, may be maintained in circumferential compression, axial loads and/or torque loads may be transmitted through the tubular sleeve. In addition, the tubular sleeve 1316 may also increase the collapse strength of the end portions, 1314 and 1326, of the first and second tubular members, 1310 and 1328.

[00142] Referring to Fig. 12a, a first tubular member 1410 includes an internally threaded connection 1412 and an annular recess 1414 at an end portion 1416. As illustrated in Fig. 12b, a first end of a tubular sleeve 1418 that includes an external flange 1420 and tapered portions, 1422 and 1424, at opposite ends is then mounted within the end portion 1416 of the first tubular member 1410. In an exemplary embodiment, the external flange 1420 of the tubular sleeve 1418 is received within and is supported by the annular recess 1414 of the end portion 1416 of the first tubular member 1410. As illustrated in Fig. 12c, an externally threaded connection 1426 of an end portion 1428 of a second tubular member 1430 is then positioned around a second end of the tubular sleeve 1418 and threadably coupled to the internally threaded connection 1412 of the end portion 1414 of the first tubular member 1410. In an exemplary embodiment, the external flange 1420 of the tubular sleeve 1418 mates with and is received within the annular recess 1414 of the end portion 1414 of the first tubular member 1410, and the external flange of the tubular sleeve is retained in the annular recess by the end portion

1428 of the second tubular member 1430. Thus, the tubular sleeve 1416 is coupled to and is surrounded by the internal surfaces of the first and second tubular members, 1410 and 1430.

[00143] In an exemplary embodiment, the internally threaded connection 1412 of the end portion 1414 of the first tubular member 1410 is a box connection, and the externally threaded connection 1426 of the end portion 1428 of the second tubular member 1430 is a pin connection. In an exemplary embodiment, the external diameter of the tubular sleeve 1418 is at least approximately .020" less than the inside diameters of the first and second tubular members, 1410 and 1430. In this manner, during the threaded coupling of the first and second tubular members, 1410 and 1430, fluidic materials within the first and second tubular members may be vented from the tubular members.

[00144] In an exemplary embodiment, as illustrated in Figs. 12d and 12e, the first and second tubular members, 1410 and 1430, and the tubular sleeve 1418 may then be positioned within another structure 32 such as, for example, a wellbore, and radially expanded and plastically deformed, for example, by moving an expansion cone 34 through the interiors of the first and second tubular members. The tapered portions, 1422 and 1424, of the tubular sleeve 1418 facilitate the movement of the expansion cone 34 through the first and second tubular members, 1410 and 1430, and the movement of the expansion cone 34 through the interiors of the first and second tubular members, 1410 and 1430, may be from top to bottom or from bottom to top.

[00145] In an exemplary embodiment, during the radial expansion and plastic deformation of the first and second tubular members, 1410 and 1430, the tubular sleeve 1418 is also radially expanded and plastically deformed. In an exemplary embodiment, as a result, the tubular sleeve 1418 may be maintained in circumferential compression and the end portions, 1414 and 1428, of the first and second tubular members, 1410 and 1430, may be maintained in circumferential tension.

[00146] In several alternative embodiments, the first and second tubular members, 1410 and 1430, are radially expanded and plastically deformed using other conventional methods for radially expanding and plastically deforming tubular members such as, for example, internal pressurization and/or roller expansion devices.

[00147] The use of the tubular sleeve 1418 during (a) the coupling of the first tubular member 1410 to the second tubular member 1430, (b) the placement of the first and second tubular members in the structure 32, and (c) the radial expansion and plastic deformation of the first and second tubular members provides a number of significant benefits. For example, the tubular sleeve 1418 provides an alignment guide that facilitates the insertion and threaded coupling of the second tubular member 1430 to the first tubular member 1410. In this manner, misalignment that could result in damage to the threaded connections, 1412 and 1426, of the first and second tubular members, 1410 and 1430, may be avoided. In addition, during the relative rotation of the second tubular member with respect to the first tubular member, required during the threaded coupling of the first and second tubular members, the tubular sleeve 1418 provides an indication of to what degree the first and second tubular members are

threadably coupled. For example, if the tubular sleeve 1418 can be easily rotated, that would indicate that the first and second tubular members, 1410 and 1430, are not fully threadably coupled and in intimate contact with the internal flange 1420 of the tubular sleeve. Furthermore, the tubular sleeve 1418 may prevent crack propagation during the radial expansion and plastic deformation of the first and second tubular members, 1410 and 1430. In this manner, failure modes such as, for example, longitudinal cracks in the end portions, 1414 and 1428, of the first and second tubular members may be limited in severity or eliminated all together. In addition, after completing the radial expansion and plastic deformation of the first and second tubular members, 1410 and 1430, the tubular sleeve 1418 may provide a fluid tight metal-to-metal seal between the exterior surface of the tubular sleeve and the interior surfaces of the end portions, 1414 and 1428, of the first and second tubular members. In this manner, fluidic materials are prevented from passing through the threaded connections, 1412 and 1426, of the first and second tubular members, 1410 and 1430, into the annulus between the first and second tubular members and the structure 32. Furthermore, because, following the radial expansion and plastic deformation of the first and second tubular members, 1410 and 1430, the tubular sleeve 1418 may be maintained in circumferential compression and the end portions, 1414 and 1428, of the first and second tubular members, 1410 and 1430, may be maintained in circumferential tension, axial loads and/or torque loads may be transmitted through the tubular sleeve. In addition, the tubular sleeve 1418 may also increase the collapse strength of the end portions, 1414 and 1428, of the first and second tubular members, 1410 and 1430.

[00148] Referring to Fig. 13a, an end of a first tubular member 1510 is positioned within and coupled to an end of a tubular sleeve 1512 having an internal flange 1514. In an exemplary embodiment, the end of the first tubular member 1510 abuts one side of the internal flange 1514. As illustrated in Fig. 13b, an end of second tubular member 1516 is then positioned within and coupled to another end of the tubular sleeve 1512. In an exemplary embodiment, the end of the second tubular member 1516 abuts another side of the internal flange 1514. In an exemplary embodiment, the tubular sleeve 1512 is coupled to the ends of the first and second tubular members, 1510 and 1516, by expanding the tubular sleeve 1512 using heat and then inserting the ends of the first and second tubular members into the expanded tubular sleeve 1512. After cooling the tubular sleeve 1512, the tubular sleeve is coupled to the ends of the first and second tubular members, 1510 and 1516.

[00149] In an exemplary embodiment, as illustrated in Figs. 13c and 13d, the first and second tubular members, 1510 and 1516, and the tubular sleeve 1512 may then be positioned within another structure 32 such as, for example, a wellbore, and radially expanded and plastically deformed, for example, by moving an expansion cone 34 through the interiors of the first and second tubular members. The movement of the expansion cone 34 through the interiors of the first and second tubular members, 1510 and 1516, may be from top to bottom or from bottom to top.

[00150] In an exemplary embodiment, during the radial expansion and plastic deformation of the

first and second tubular members, 1510 and 1516, the tubular sleeve 1512 is also radially expanded and plastically deformed. In an exemplary embodiment, as a result, the tubular sleeve 1512 may be maintained in circumferential tension and the ends of the first and second tubular members, 1510 and 1516, may be maintained in circumferential compression.

[00151] The use of the tubular sleeve 1512 during (a) the placement of the first and second tubular members, 1510 and 1516, in the structure 32 and (b) the radial expansion and plastic deformation of the first and second tubular members provides a number of significant benefits. For example, the tubular sleeve 1512 may prevent crack propagation during the radial expansion and plastic deformation of the first and second tubular members, 1510 and 1516. In this manner, failure modes such as, for example, longitudinal cracks in the ends of the first and second tubular members, 1510 and 1516, may be limited in severity or eliminated all together. In addition, after completing the radial expansion and plastic deformation of the first and second tubular members, 1510 and 1516, the tubular sleeve 1512 may provide a fluid tight metal-to-metal seal between the exterior surface of the tubular sleeve and the interior surfaces of the end of the first and second tubular members. Furthermore, because, following the radial expansion and plastic deformation of the first and second tubular members, 1510 and 1516, the tubular sleeve 1512 may be maintained in circumferential compression and the ends of the first and second tubular members, 1510 and 1516, may be maintained in circumferential tension, axial loads and/or torque loads may be transmitted through the tubular sleeve. In addition, the tubular sleeve 1512 may also increase the collapse strength of the end portions of the first and second tubular members, 1510 and 1516.

[00152] Referring to Fig. 14a, a first tubular member 1610 includes a resilient retaining ring 1612 mounted within an annular recess 1614. As illustrated in Fig. 14b, the end of the first tubular member 1610 is then inserted into and coupled to an end of a tubular sleeve 1616 including an internal flange 1618 and annular recesses, 1620 and 1622, positioned on opposite sides of the internal flange, tapered portions, 1624 and 1626, on one end of the tubular sleeve, and tapered portions, 1628 and 1630, on the other end of the tubular sleeve. In an exemplary embodiment, the resilient retaining ring 1612 is thereby positioned at least partially in the annular recesses, 1614 and 1620, thereby coupling the first tubular member 1610 to the tubular sleeve 1616, and the end of the first tubular member 1610 abuts one side of the internal flange 1618. During the coupling of the first tubular member 1610 to the tubular sleeve 1616, the tapered portion 1630 facilitates the radial compression of the resilient retaining ring 1612 during the insertion of the first tubular member into the tubular sleeve.

[00153] As illustrated in Fig. 14c, an end of a second tubular member 1632 that includes a resilient retaining ring 1634 mounted within an annular recess 1636 is then inserted into and coupled to another end of the tubular sleeve 1616. In an exemplary embodiment, the resilient retaining ring 1634 is thereby positioned at least partially in the annular recesses, 1636 and 1622, thereby coupling the second tubular member 1632 to the tubular sleeve 1616, and the end of the second tubular member

1632 abuts another side of the internal flange 1618. During the coupling of the second tubular member 1632 to the tubular sleeve 1616, the tapered portion 1626 facilitates the radial compression of the resilient retaining ring 1634 during the insertion of the second tubular member into the tubular sleeve.

[00154] In an exemplary embodiment, as illustrated in Figs. 14d and 14e, the first and second tubular members, 1610 and 1632, and the tubular sleeve 1616 may then be positioned within another structure 32 such as, for example, a wellbore, and radially expanded and plastically deformed, for example, by moving an expansion cone 34 through the interiors of the first and second tubular members. The movement of the expansion cone 34 through the interiors of the first and second tubular members, 1610 and 1632, may be from top to bottom or from bottom to top.

[00155] In an exemplary embodiment, during the radial expansion and plastic deformation of the first and second tubular members, 1610 and 1632, the tubular sleeve 1616 is also radially expanded and plastically deformed. In an exemplary embodiment, as a result, the tubular sleeve 1616 may be maintained in circumferential tension and the ends of the first and second tubular members, 1610 and 1632, may be maintained in circumferential compression.

[00156] The use of the tubular sleeve 1616 during (a) the placement of the first and second tubular members, 1610 and 1632, in the structure 32, and (b) the radial expansion and plastic deformation of the first and second tubular members provides a number of significant benefits. For example, the tubular sleeve 1616 protects the exterior surfaces of the ends of the first and second tubular members, 1610 and 1632, during handling and insertion of the tubular members within the structure 32. In this manner, damage to the exterior surfaces of the ends of the first and second tubular member, 1610 and 1632, are prevented that could result in stress concentrations that could result in a catastrophic failure during subsequent radial expansion operations. Furthermore, the tubular sleeve 1616 may prevent crack propagation during the radial expansion and plastic deformation of the first and second tubular members, 1610 and 1632. In this manner, failure modes such as, for example, longitudinal cracks in the ends of the first and second tubular members, 1610 and 1632, may be limited in severity or eliminated all together. In addition, after completing the radial expansion and plastic deformation of the first and second tubular members, 1610 and 1632, the tubular sleeve 1616 may provide a fluid tight metal-to-metal seal between interior surface of the tubular sleeve and the exterior surfaces of the ends of the first and second tubular members. Furthermore, because, following the radial expansion and plastic deformation of the first and second tubular members, 1610 and 1632, the tubular sleeve 1616 may be maintained in circumferential tension and the ends of the first and second tubular members, 1610 and 1632, may be maintained in circumferential compression, axial loads and/or torque loads may be transmitted through the tubular sleeve. In addition, the tubular sleeve 1616 may also increase the collapse strength of the end portions of the first and second tubular members, 1610 and 1632.

[00157] Referring to Fig. 15a, a first tubular member 1700 defines a passage 1702 and a counterbore 1704 at an end portion 1706. The counterbore 1704 includes a tapered shoulder 1708, an

annular recess 1710, non-tapered internal threads, 1712, and tapered internal threads 1714. A second tubular member 1716 that defines a passage 1718 includes a recessed portion 1720 at an end portion 1722 that includes a tapered end portion 1724 that is adapted to mate with the tapered shoulder 1708 of the counterbore 1704 of the first tubular member 1700, non-tapered external threads 1726 adapted to mate with the non-tapered internal threads 1712 of the counterbore of the first tubular member, and tapered external threads 1728 adapted to mate with the tapered internal threads 1714 of the counterbore of the first tubular member. A sealing ring 1730 is received within the annular recess 1710 of the counterbore 1704 of the of the first tubular member 1700 for fluidicly sealing the interface between the counterbore of the first tubular member and the recessed portion 1720 of the second tubular member 1716. In an exemplary embodiment, the threads, 1712, 1714, 1726, and 1728, are left-handed threads in order to prevent de-coupling of the first and second tubular members, 1700 and 1716, during placement of the tubular members within the structure 32. In an exemplary embodiment, the sealing ring 1730 is an elastomeric sealing ring.

[00158] A tubular sleeve 1732 that defines a passage 1734 for receiving the end portions, 1706 and 1722, of the first and second tubular members, 1700 and 1716, respectively, includes an internal flange 1736 that mates with and is received within an annular recess 1738 that is defined between an end face 1740 of the end portion of the first tubular member and an end face 1742 of the recessed portion 1720 of the end portion of the second tubular member. In this manner, the tubular sleeve 1732 is coupled to the first and second tubular members, 1700 and 1716. The tubular sleeve 1732 further includes first and second internal annular recesses, 1744 and 1746, internal tapered flanges, 1748 and 1750, and external tapered flanges, 1752 and 1754.

[00159] Sealing members, 1756 and 1758, are received within and mate with the internal annular recesses, 1744 and 1746, respectively, of the tubular sleeve 1732 that fluidicly seal the interface between the tubular sleeve and the first and second tubular members, 1700 and 1716, respectively. A sealing member 1760 is coupled to the exterior surface of the tubular sleeve 1732 for fluidicly sealing the interface between the tubular sleeve and the interior surface of the preexisting structure 32 following the radial expansion of the first and second tubular members, 1700 and 1716, and the tubular sleeve using the expansion cone 34. In an exemplary embodiment, the sealing members, 1756 and 1758, may be, for example, elastomeric or non-elastomeric sealing members fabricated from nitrile, viton, or Teflon< materials. In an exemplary embodiment, the sealing member 1760 is fabricated from an elastomeric material.

[00160] In an exemplary embodiment, during the radial expansion and plastic deformation of the first and second tubular members, 1700 and 1716, the tubular sleeve 1732 is also radially expanded and plastically deformed. In an exemplary embodiment, as a result of the radial expansion, the tubular sleeve 1732 may be maintained in circumferential tension and the end portions, 1706 and 1722, of the first and second tubular members, 1700 and 1716, may be maintained in circumferential compression.

Furthermore, in an exemplary embodiment, during and following the radial expansion and plastic deformation of the first and second tubular members, 1700 and 1716, respectively: (a) the sealing members, 1756 and 1758, of the tubular sleeve 1732 engage and fluidically seal the interface between the tubular sleeve and the end portions, 1706 and 1722, of the first and second tubular members, (b) the internal tapered flanges, 1748 and 1750, of the tubular sleeve engage, and couple the tubular sleeve to, the end portions of the first and second tubular members, (c) the external tapered flanges, 1752 and 1754, of the tubular sleeve engage, and couple the tubular sleeve to, the structure 32, and (d) the sealing member 1760 engages and fluidically seals the interface between the tubular sleeve and the structure.

[00161] In several exemplary embodiments, the first and second tubular members, 1700 and 1716, are radially expanded and plastically deformed using the expansion cone 34 in a conventional manner and/or using one or more of the methods and apparatus disclosed in one or more of the following: (1) U.S. patent application serial no. 09/454,139, attorney docket no. 25791.03.02, filed on 12/3/1999, (2) U.S. patent application serial no. 09/510,913, attorney docket no. 25791.7.02, filed on 2/23/2000, (3) U.S. patent application serial no. 09/502,350, attorney docket no. 25791.8.02, filed on 2/10/2000, (4) U.S. patent application serial no. 09/440,338, attorney docket no. 25791.9.02, filed on 11/15/1999, (5) U.S. patent application serial no. 09/523,460, attorney docket no. 25791.11.02, filed on 3/10/2000, (6) U.S. patent application serial no. 09/512,895, attorney docket no. 25791.12.02, filed on 2/24/2000, (7) U.S. patent application serial no. 09/511,941, attorney docket no. 25791.16.02, filed on 2/24/2000, (8) U.S. patent application serial no. 09/588,946, attorney docket no. 25791.17.02, filed on 6/7/2000, (9) U.S. patent application serial no. 09/559,122, attorney docket no. 25791.23.02, filed on 4/26/2000, (10) PCT patent application serial no. PCT/US00/18635, attorney docket no. 25791.25.02, filed on 7/9/2000, (11) U.S. provisional patent application serial no. 60/162,671, attorney docket no. 25791.27, filed on 11/1/1999, (12) U.S. provisional patent application serial no. 60/154,047, attorney docket no. 25791.29, filed on 9/16/1999, (13) U.S. provisional patent application serial no. 60/159,082, attorney docket no. 25791.34, filed on 10/12/1999, (14) U.S. provisional patent application serial no. 60/159,039, attorney docket no. 25791.36, filed on 10/12/1999, (15) U.S. provisional patent application serial no. 60/159,033, attorney docket no. 25791.37, filed on 10/12/1999, (16) U.S. provisional patent application serial no. 60/212,359, attorney docket no. 25791.38, filed on 6/19/2000, (17) U.S. provisional patent application serial no. 60/165,228, attorney docket no. 25791.39, filed on 11/12/1999, (18) U.S. provisional patent application serial no. 60/221,443, attorney docket no. 25791.45, filed on 7/28/2000, (19) U.S. provisional patent application serial no. 60/221,645, attorney docket no. 25791.46, filed on 7/28/2000, (20) U.S. provisional patent application serial no. 60/233,638, attorney docket no. 25791.47, filed on 9/18/2000, (21) U.S. provisional patent application serial no. 60/237,334, attorney docket no. 25791.48, filed on 10/2/2000, (22) U.S. provisional patent application serial no. 60/270,007, attorney docket no. 25791.50, filed on 2/20/2001, (23) U.S.

provisional patent application serial no. 60/262,434, attorney docket no. 25791.51, filed on 1/17/2001, (24) U.S. provisional patent application serial no. 60/259,486, attorney docket no. 25791.52, filed on 1/3/2001, (25) U.S. provisional patent application serial no. 60/303,740, attorney docket no. 25791.61, filed on 7/6/2001, (26) U.S. provisional patent application serial no. 60/313,453, attorney docket no. 25791.59, filed on 8/20/2001, (27) U.S. provisional patent application serial no. 60/317,985, attorney docket no. 25791.67, filed on 9/6/2001, (28) U.S. provisional patent application serial no. 60/3318,386, attorney docket no. 25791.67.02, filed on 9/10/2001, (29) U.S. utility patent application serial no. 09/969,922, attorney docket no. 25791.69, filed on 10/3/2001, (30) U.S. utility patent application serial no. 10/016,467, attorney docket no. 25791.70, filed on 12/10/2001; (31) U.S. provisional patent application serial no. 60/343,674, attorney docket no. 25791.68, filed on 12/27/2001; (32) U.S. provisional patent application serial no. 60/346,309, attorney docket no. 25791.92, filed on 1/7/2002; (33) U.S. provisional patent application serial no. 60/372,048, attorney docket no. 25791.93, filed on 4/12/2002; (34) U.S. provisional patent application serial no. 60/380,147, attorney docket no. 25791.104, filed on 5/6/2002; (35) U.S. provisional patent application serial no. 60/387,486, attorney docket no. 25791.107, filed on 6/10/2002; (36) U.S. provisional patent application serial no. 60/387,961, attorney docket no. 25791.108, filed on 6/12/2002; (37) U.S. provisional patent application serial no. 60/391,703, attorney docket no. 25791.90, filed on 6/26/2002; and (38) U.S. provisional patent application serial no. 60/397,284, attorney docket no. 25791.106, filed on 7/19/2002, the disclosures of which are incorporated herein by reference.

[00162] In several alternative embodiments, the first and second tubular members, 1700 and 1716, are radially expanded and plastically deformed using other conventional methods for radially expanding and plastically deforming tubular members such as, for example, internal pressurization and/or roller expansion devices such as, for example, that disclosed in U.S. patent application publication no. US 2001/0045284 A1, the disclosure of which is incorporated herein by reference.

[00163] The use of the tubular sleeve 1732 during (a) the threaded coupling of the first tubular member 1700 to the second tubular member 1716, (b) the placement of the first and second tubular members in the structure 32, and (c) the radial expansion and plastic deformation of the first and second tubular members provides a number of significant benefits. For example, the tubular sleeve 1732 protects the exterior surfaces of the end portions, 1706 and 1722, of the first and second tubular members, 1700 and 1716, during handling and insertion of the tubular members within the structure 32. In this manner, damage to the exterior surfaces of the end portions, 1706 and 1722, of the first and second tubular member, 1700 and 1716, are prevented that could result in stress concentrations that could result in a catastrophic failure during subsequent radial expansion operations. Furthermore, the tubular sleeve 1732 provides an alignment guide that facilitates the insertion and threaded coupling of the second tubular member 1716 to the first tubular member 1700. In this manner, misalignment that could result in damage to the threaded connections, 1712, 1714, 1726, and 1728, of the first and

second tubular members, 1700 and 1716, may be avoided. In addition, during the relative rotation of the second tubular member with respect to the first tubular member, required during the threaded coupling of the first and second tubular members, the tubular sleeve 1732 provides an indication of to what degree the first and second tubular members are threadably coupled. For example, if the tubular sleeve 1732 can be easily rotated, that would indicate that the first and second tubular members, 1700 and 1716, are not fully threadably coupled and in intimate contact with the internal flange 1736 of the tubular sleeve. Furthermore, the tubular sleeve 1732 may prevent crack propagation during the radial expansion and plastic deformation of the first and second tubular members, 1700 and 1716. In this manner, failure modes such as, for example, longitudinal cracks in the end portions, 1706 and 1722, of the first and second tubular members may be limited in severity or eliminated all together. In addition, after completing the radial expansion and plastic deformation of the first and second tubular members, 1700 and 1716, the tubular sleeve 16 may provide a fluid tight metal-to-metal seal between interior surface of the tubular sleeve and the exterior surfaces of the end portions, 1706 and 1722, of the first and second tubular members. In this manner, fluidic materials are prevented from passing through the threaded connections, 1712, 1714, 1726, and 1728, of the first and second tubular members, 1700 and 1716, into the annulus between the first and second tubular members and the structure 32.

Furthermore, because, following the radial expansion and plastic deformation of the first and second tubular members, 1700 and 1716, the tubular sleeve 1732 may be maintained in circumferential tension and the end portions, 1706 and 1722, of the first and second tubular members, 1700 and 1716, may be maintained in circumferential compression, axial loads and/or torque loads may be transmitted through the tubular sleeve. In addition, the tubular sleeve 1732 may also increase the collapse strength of the end portions, 1706 and 1722, of the first and second tubular members, 1700 and 1716.

[00164] In an exemplary experimental implementation, following the radial expansion and plastic deformation of the first and second tubular members, 1700 and 1716, and the tubular sleeve 1732, the threads, 1712, 1714, 1726, and 1728, of the end portions, 1706 and 1722, of the first and second tubular members were unexpectedly deformed such that a fluidic seal was unexpectedly formed between and among the threads of the first and second tubular members. In this manner, a fluid tight seal was unexpectedly provided between the first and second tubular member, 1700 and 1716, due to the presence of the tubular sleeve 1732 during the radial expansion and plastic deformation of the end portions, 1706 and 1722, of the first and second tubular members.

[00165] In an exemplary embodiment, the rate and degree of radial expansion and plastic deformation of the first and second tubular members, 1700 and 1716, and the tubular sleeve 1732 are adjusted to generate sufficient localized heating to result in amorphous bonding or welding of the threads, 1712, 1714, 1726, and 1728. As a result, the first and second tubular members, 1700 and 1716, may be amorphously bonded resulting a joint between the first and second tubulars that is nearly metallurgically homogeneous.

[00166] In an alternative embodiment, as illustrated in Fig. 15c, a metallic foil 1762 of a suitable alloy is placed between and among the threads, 1712, 1714, 1726, and 1728, and during the radial expansion and plastic deformation of the first and second tubular members, 1700 and 1716, and the tubular sleeve 1732, localized heating of the region proximate the threads, 1712, 1714, 1726, and 1728, results in amorphous bonding or a brazing joint of the threads. As a result, the first and second tubular members, 1700 and 1716, may be amorphously bonded resulting a joint between the first and second tubulars that is nearly metallurgically homogeneous.

[00167] In an exemplary embodiment, as illustrated in Fig. 16, a plurality of overlapping wellbore casing strings 1800a-1800h, are positioned within a borehole 1802 that traverses a subterranean source 1804 of geothermal energy. In this manner, geothermal energy may then be extracted from the subterranean source 1804 geothermal energy using conventional methods of extraction. In an exemplary embodiment, one or more of the wellbore casing strings 1800 include one or more of the first and second tubular members, 10, 28, 910, 938, 1010, 1036, 1110, 1128, 1210, 1232, 1310, 1328, 1410, 1430, 1510, 1516, 1610, 1632, 1700 and/or 1716, that are coupled end-to-end and include one or more of the tubular sleeves, 16, 110, 210, 310, 410, 510, 610, 710, 810, 918, 1018, 1116, 1216, 1316, 1418, 1512, 1616 and/or 1732.

[00168] In an exemplary embodiment, the wellbore casing strings, 1800a-1800h, are radially expanded and plastically deformed in overlapping fashion within the borehole 1802.

[00169] For example, the wellbore casing string 1800a is positioned within the borehole 1802 and then radially expanded and plastically deformed. The wellbore casing string 1800b is then positioned within the borehole 1802 in overlapping relation to the wellbore casing string 1800a and then radially expanded and plastically deformed. In this manner, a mono-diameter wellbore casing may be formed that includes the overlapping wellbore casing strings 1800a and 1800b. This process may then be repeated for wellbore casing strings 1800c-1800h. As a result, a mono-diameter wellbore casing may be produced that extends from a surface location to the source 1804 of geothermal energy in which the inside diameter of a passage 1806 defined by the interiors of the wellbore casing strings 1800a-1800h is constant. In this manner, the geothermal energy from the source 1804 may be efficiently and economically extracted. Furthermore, because variations in the inside diameter of the wellbore casing strings 1800 is eliminated by the resulting mono-diameter design, the depth of the borehole 1802 may be virtually limitless. As a result, using the teachings of the present exemplary embodiments, sources of geothermal energy can now be extracted from depths of over 50,000 feet.

[00170] In several exemplary embodiments, the wellbore casing strings 1800a-1800h are radially expanded and plastically deformed using the expansion cone 34 using one or more of the methods and apparatus disclosed in one or more of the following: (1) U.S. patent application serial no. 09/454,139, attorney docket no. 25791.03.02, filed on 12/3/1999, (2) U.S. patent application serial no. 09/510,913, attorney docket no. 25791.7.02, filed on 2/23/2000, (3) U.S. patent application serial no. 09/502,350,

attorney docket no. 25791.8.02, filed on 2/10/2000, (4) U.S. patent application serial no. 09/440,338, attorney docket no. 25791.9.02, filed on 11/15/1999, (5) U.S. patent application serial no. 09/523,460, attorney docket no. 25791.11.02, filed on 3/10/2000, (6) U.S. patent application serial no. 09/512,895, attorney docket no. 25791.12.02, filed on 2/24/2000, (7) U.S. patent application serial no. 09/511,941, attorney docket no. 25791.16.02, filed on 2/24/2000, (8) U.S. patent application serial no. 09/588,946, attorney docket no. 25791.17.02, filed on 6/7/2000, (9) U.S. patent application serial no. 09/559,122, attorney docket no. 25791.23.02, filed on 4/26/2000, (10) PCT patent application serial no. PCT/US00/18635, attorney docket no. 25791.25.02, filed on 7/9/2000, (11) U.S. provisional patent application serial no. 60/162,671, attorney docket no. 25791.27, filed on 11/1/1999, (12) U.S. provisional patent application serial no. 60/154,047, attorney docket no. 25791.29, filed on 9/16/1999, (13) U.S. provisional patent application serial no. 60/159,082, attorney docket no. 25791.34, filed on 10/12/1999, (14) U.S. provisional patent application serial no. 60/159,039, attorney docket no. 25791.36, filed on 10/12/1999, (15) U.S. provisional patent application serial no. 60/159,033, attorney docket no. 25791.37, filed on 10/12/1999, (16) U.S. provisional patent application serial no. 60/212,359, attorney docket no. 25791.38, filed on 6/19/2000, (17) U.S. provisional patent application serial no. 60/165,228, attorney docket no. 25791.39, filed on 11/12/1999, (18) U.S. provisional patent application serial no. 60/221,443, attorney docket no. 25791.45, filed on 7/28/2000, (19) U.S. provisional patent application serial no. 60/221,645, attorney docket no. 25791.46, filed on 7/28/2000, (20) U.S. provisional patent application serial no. 60/233,638, attorney docket no. 25791.47, filed on 9/18/2000, (21) U.S. provisional patent application serial no. 60/237,334, attorney docket no. 25791.48, filed on 10/2/2000, (22) U.S. provisional patent application serial no. 60/270,007, attorney docket no. 25791.50, filed on 2/20/2001, (23) U.S. provisional patent application serial no. 60/262,434, attorney docket no. 25791.51, filed on 1/17/2001, (24) U.S. provisional patent application serial no. 60/259,486, attorney docket no. 25791.52, filed on 1/3/2001, (25) U.S. provisional patent application serial no. 60/303,740, attorney docket no. 25791.61, filed on 7/6/2001, (26) U.S. provisional patent application serial no. 60/313,453, attorney docket no. 25791.59, filed on 8/20/2001, (27) U.S. provisional patent application serial no. 60/317,985, attorney docket no. 25791.67, filed on 9/6/2001, (28) U.S. provisional patent application serial no. 60/3318,386, attorney docket no. 25791.67.02, filed on 9/10/2001, (29) U.S. utility patent application serial no. 09/969,922, attorney docket no. 25791.69, filed on 10/3/2001, (30) U.S. utility patent application serial no. 10/016,467, attorney docket no. 25791.70, filed on 12/10/2001; (31) U.S. provisional patent application serial no. 60/343,674, attorney docket no. 25791.68, filed on 12/27/2001; (32) U.S. provisional patent application serial no. 60/346,309, attorney docket no. 25791.92, filed on 1/7/2002; (33) U.S. provisional patent application serial no. 60/372,048, attorney docket no. 25791.93, filed on 4/12/2002; (34) U.S. provisional patent application serial no. 60/380,147, attorney docket no. 25791.104, filed on 5/6/2002; (35) U.S. provisional patent application serial no. 60/387,486, attorney docket no.

25791.107, filed on 6/10/2002; (36) U.S. provisional patent application serial no. 60/387,961, attorney docket no. 25791.108, filed on 6/12/2002; (37) U.S. provisional patent application serial no. 60/391,703, attorney docket no. 25791.90, filed on 6/26/2002; and (38) U.S. provisional patent application serial no. 60/397,284, attorney docket no. 25791.106, filed on 7/19/2002, the disclosures of which are incorporated herein by reference.

[00171] Referring to Fig. 17a, a first tubular member 1900 defines a passage 1902 and a counterbore 1904 at an end portion 1906. The counterbore 1904 includes non-tapered internal threads 1908, and tapered internal threads 1910. A second tubular member 1912 that defines a passage 1914 includes a recessed portion 1916 at an end portion 1918 that includes non-tapered external threads 1920 adapted to mate with the non-tapered internal threads 1908 of the counterbore of the first tubular member, and tapered external threads 1922 adapted to mate with the tapered internal threads 1910 of the counterbore of the first tubular member. In an exemplary embodiment, the threads, 1908, 1910, 1920, and 1922, are left-handed threads in order to prevent de-coupling of the first and second tubular members, 1900 and 1912, during handling of tubular members.

[00172] A tubular sleeve 1924 that defines a passage 1926 for receiving the end portions, 1906 and 1918, of the first and second tubular members, 1900 and 1912, respectively, includes an internal flange 1928 that mates with and is received within an annular recess 1930 that is defined between an end face 1932 of the end portion of the first tubular member and an end face 1934 of the recessed portion 1916 of the end portion of the second tubular member. In this manner, the tubular sleeve 1924 is coupled to the first and second tubular members, 1900 and 1912.

[00173] An adjustable expansion cone 1936 supported by a support member 1938 may then be lowered into the first and second tubular members, 1900 and 1912, to a position proximate the vicinity of the threads, 1908, 1910, 1920, and 1922. As illustrated in Fig. 17b, The expansion cone 1936 may then be controllably increased in size until the outside circumference of the expansion cone engages and radially expands and plastically deforms the end portions of the first and second tubular members, 1900 and 1912, proximate the expansion cone. The expansion cone 1936 may then be displaced in the longitudinal direction 1940 thereby radially expanding and plastically deforming the remaining portions of the first and second tubular members, 1900 and 1912, in the vicinity of the threads, 1908, 1910, 1920, and 1922. In several exemplary embodiments, the amount of radial expansion ranged from less than about one percent to less than about five percent.

[00174] After completing the radial expansion and plastic deformation of the portions 1942 of the first and second tubular members, 1900 and 1912, in the vicinity of the threads, 1908, 1910, 1920, and 1922, the expansion cone 1936 may then be controllably reduced in size until the outside circumference of the expansion cone disengages from the portion of the second tubular above the portion of the second tubular member in the vicinity of the threads. In this manner, only the portions 1942 of the first and second tubular members, 1900 and 1912, in the vicinity of the threads, 1908,

1910, 1920, and 1922, are radially expanded and plastically deformed.

[00175] In several exemplary embodiments, the portions 1942 of the first and second tubular members, 1900 and 1912, in the vicinity of the threads, 1908, 1910, 1920, are radially expanded and plastically deformed using one or more of the methods and apparatus disclosed in one or more of the following: (1) U.S. patent application serial no. 09/454,139, attorney docket no. 25791.03.02, filed on 12/3/1999, (2) U.S. patent application serial no. 09/510,913, attorney docket no. 25791.7.02, filed on 2/23/2000, (3) U.S. patent application serial no. 09/502,350, attorney docket no. 25791.8.02, filed on 2/10/2000, (4) U.S. patent application serial no. 09/440,338, attorney docket no. 25791.9.02, filed on 11/15/1999, (5) U.S. patent application serial no. 09/523,460, attorney docket no. 25791.11.02, filed on 3/10/2000, (6) U.S. patent application serial no. 09/512,895, attorney docket no. 25791.12.02, filed on 2/24/2000, (7) U.S. patent application serial no. 09/511,941, attorney docket no. 25791.16.02, filed on 2/24/2000, (8) U.S. patent application serial no. 09/588,946, attorney docket no. 25791.17.02, filed on 6/7/2000, (9) U.S. patent application serial no. 09/559,122, attorney docket no. 25791.23.02, filed on 4/26/2000, (10) PCT patent application serial no. PCT/US00/18635, attorney docket no. 25791.25.02, filed on 7/9/2000, (11) U.S. provisional patent application serial no. 60/162,671, attorney docket no. 25791.27, filed on 11/1/1999, (12) U.S. provisional patent application serial no. 60/154,047, attorney docket no. 25791.29, filed on 9/16/1999, (13) U.S. provisional patent application serial no. 60/159,082, attorney docket no. 25791.34, filed on 10/12/1999, (14) U.S. provisional patent application serial no. 60/159,039, attorney docket no. 25791.36, filed on 10/12/1999, (15) U.S. provisional patent application serial no. 60/159,033, attorney docket no. 25791.37, filed on 10/12/1999, (16) U.S. provisional patent application serial no. 60/212,359, attorney docket no. 25791.38, filed on 6/19/2000, (17) U.S. provisional patent application serial no. 60/165,228, attorney docket no. 25791.39, filed on 11/12/1999, (18) U.S. provisional patent application serial no. 60/221,443, attorney docket no. 25791.45, filed on 7/28/2000, (19) U.S. provisional patent application serial no. 60/221,645, attorney docket no. 25791.46, filed on 7/28/2000, (20) U.S. provisional patent application serial no. 60/233,638, attorney docket no. 25791.47, filed on 9/18/2000, (21) U.S. provisional patent application serial no. 60/237,334, attorney docket no. 25791.48, filed on 10/2/2000, (22) U.S. provisional patent application serial no. 60/270,007, attorney docket no. 25791.50, filed on 2/20/2001, (23) U.S. provisional patent application serial no. 60/262,434, attorney docket no. 25791.51, filed on 1/17/2001, (24) U.S. provisional patent application serial no. 60/259,486, attorney docket no. 25791.52, filed on 1/3/2001, (25) U.S. provisional patent application serial no. 60/303,740, attorney docket no. 25791.61, filed on 7/6/2001, (26) U.S. provisional patent application serial no. 60/313,453, attorney docket no. 25791.59, filed on 8/20/2001, (27) U.S. provisional patent application serial no. 60/317,985, attorney docket no. 25791.67, filed on 9/6/2001, (28) U.S. provisional patent application serial no. 60/3318,386, attorney docket no. 25791.67.02, filed on 9/10/2001, (29) U.S. utility patent application serial no. 09/969,922, attorney docket no. 25791.69, filed on 10/3/2001, (30)

U.S. utility patent application serial no. 10/016,467, attorney docket no. 25791.70, filed on 12/10/2001; (31) U.S. provisional patent application serial no. 60/343,674, attorney docket no. 25791.68, filed on 12/27/2001; (32) U.S. provisional patent application serial no. 60/346,309, attorney docket no 25791.92, filed on 1/7/2002; (33) U.S. provisional patent application serial no. 60/372,048, attorney docket no. 25791.93, filed on 4/12/2002; (34) U.S. provisional patent application serial no. 60/380,147, attorney docket no. 25791.104, filed on 5/6/2002; (35) U.S. provisional patent application serial no. 60/387,486, attorney docket no. 25791.107, filed on 6/10/2002; (36) U.S. provisional patent application serial no. 60/387,961, attorney docket no. 25791.108, filed on 6/12/2002; (37) U.S. provisional patent application serial no. 60/391,703, attorney docket no. 25791.90, filed on 6/26/2002; and (38) U.S. provisional patent application serial no. 60/397,284, attorney docket no. 25791.106, filed on 7/19/2002, the disclosures of which are incorporated herein by reference.

[00176] As illustrated in Fig. 17c, in an exemplary experimental implementation, prior to the radial expansion and plastic deformation of the portions 1942 of the first and second tubular members, 1900 and 1912, in the vicinity of the threads, 1908, 1910, 1920, and 1922, a variable gap 1944 is typically present between the threads, 1908 and 1920, and 1910 and 1922, that may permit fluidic materials to pass there through. The gap 1944 may be present, for example, in the radial, longitudinal and/or circumferential directions. The leakage of fluidic materials through the gap 1944 can cause serious problems, for example, in the extraction of subterranean fluids during oil or gas exploration and production operations, during the transport of hydrocarbons using underground pipelines, during the transport of pressurized fluids in a chemical processing plant, or within the heat exchanger tubes of a power plant.

[00177] In an exemplary experimental implementation, as illustrated in Fig. 17d, following the radial expansion and plastic deformation of the portion 1942 of the first and second tubular members, 1900 and 1912, in the vicinity of the threads, 1908, 1910, 1920, and 1922, the gap 1944 between the threads was unexpectedly eliminated thereby creating a fluid tight seal. As a result a fluid tight seal may be provided within the threads, 1908, 1910, 1920, and 1922, of the first and second tubular members, 1900 and 1912, without an elastomeric, or other conventional, sealing element present.

[00178] Furthermore, in an exemplary experimental implementation, following the radial expansion and plastic deformation of the portions 1942 of the first and second tubular members, 1900 and 1912, in the vicinity of the threads, 1908, 1910, 1920, and 1922, a fluid tight seal was also created between the interior circumference of the tubular sleeve 1924 and the exterior circumferences of the first and second tubular members, 1900 and 1912.

[00179] Thus, the teachings of the present illustrative embodiments of Figs. 17a-17d may also be used to provide a fluid tight seal between the first and second tubular members, 10, 28, 910, 938, 1010, 1036, 1110, 1128, 1210, 1232, 1310, 1328, 1410, 1430, 1510, 1516, 1610, 1632, 1700 and/or 1716, that are coupled end-to-end and include one or more of the tubular sleeves, 16, 110, 210, 310, 410,

510, 610, 710, 810, 918, 1018, 1116, 1216, 1316, 1418, 1512, 1616 and/or 1732. A fluid tight seal may thereby be formed within the threaded connection between the adjacent tubular members and/or between the tubular sleeve and the adjacent tubular members.

[00180] More generally, the teachings of the present illustrative embodiments may be used to solve the problem of providing a fluid tight seal between all types of tubular members such as, for example, wellbore casings, pipes, underground pipelines, piping used in the transport of pressurized fluids in a chemical processing plant, or within the heat exchanger tubes of a power plant.

[00181] Furthermore, the teachings of the present illustrative embodiments may be used to solve the problem of providing a fluid tight seal between all types of tubular members such as, for example, wellbore casings, chemical processing pipes and underground pipelines, without having to radially expand and plastically deform the entire length of the tubular members. Instead, only those portions of the tubular members proximate the tubular sleeve provided adjacent to the joint between the tubular members needs to be radially expanded and plastically deformed. Furthermore, in an exemplary embodiment, the amount of radial expansion and plastic deformation ranged from less than about one percent to less than about five percent. As a result, the amount of time and resources typically needed to perform the radial expansion and plastic deformation is economical.

[00182] More generally, the teachings of the exemplary embodiments may be used to provide an inexpensive and reliable fluid tight seal between tubular members. In this manner, expensive and unreliable methods of providing a fluid tight seal between tubular members such as, for example, those methods utilized in the chemical processing industries and in power plant heat exchangers may be replaced with the teachings of the present illustrative embodiments.

[00183] Furthermore, the teachings of the exemplary embodiments provide a method of radially expanding and plastically deforming the ends of adjacent coupled tubular members in which the freedom of movement of the adjacent ends of the coupled tubular members is constrained by the presence of the tubular sleeve. As a result, during the subsequent radial expansion process, the adjacent ends of the coupled tubular members are compressed into the plastic region of the stress-strain curve. Consequently, the material of the adjacent ends of the coupled tubular members such as, for example, the internal and external threads, flow into and fill any gaps or voids that may have existed within the junction of the coupled tubular members thereby providing a fluid tight seal. The creation of the fluid tight seal within the junction of the adjacent tubular members was an unexpected result that was discovered during experimental analysis and testing of the present exemplary embodiments. In fact, also unexpectedly, during a further exemplary analysis and testing of the present exemplary embodiments, a fluid tight seal was maintained within the junction between two adjacent tubulars despite being bent over 60 degrees relative to one another.

[00184] Thus the present exemplary embodiments will eliminate the need for expensive high precision threaded connection for tubular members in order to provide a fluid tight seal. Instead, a

fluid tight seal can now be provided using a combination of less expensive conventional threaded connection and a tubular sleeve that are then radially expanded to provide a fluid tight seal. Thus, the commercial application of the present exemplary embodiments will dramatically reduce the cost of oil and gas exploration and production. Furthermore, the teachings of the present exemplary embodiments can be extended to provide a fluid tight seal between adjacent tubular members in other applications such as, for example, underground pipelines, piping in chemical processing plants, and piping in power plants, in which conventional, inexpensive, piping with conventional threaded connections can be coupled together with a tubular sleeve and then radially expanded to provide an inexpensive and reliable fluid tight seal between the adjacent pipe sections.

[00185] Referring to Figs. 18a and 18b, in an alternative embodiment, a conventional rotary expansion tool 2000 may then be lowered into the first and second tubular members, 1900 and 1912, to a position proximate the vicinity of the threads, 1908, 1910, 1920, and 1922. In an exemplary embodiment, the rotary expansion tool 2000 may be, for example, a rotary expansion tool as disclosed in U.S. Patent Application Publication No. US 2001/0045284, published on November 29, 2001, the disclosure of which is incorporated herein by reference.

[00186] As illustrated in Fig. 18b, The rotary expansion tool 2000 may then be controllably increased in size and operated until the outside circumference of the rotary expansion tool engages and radially expands and plastically deforms the end portions of the first and second tubular members, 1900 and 1912, proximate the expansion cone. The rotary expansion tool 2000 may then be displaced in the longitudinal direction 2002 thereby radially expanding and plastically deforming the remaining portions of the first and second tubular members, 1900 and 1912, in the vicinity of the threads, 1908, 1910, 1920, and 1922. In an exemplary embodiment, the amount of radial expansion is less than about five percent. After completing the radial expansion and plastic deformation of the portion 1942 of the first and second tubular members, 1900 and 1912, in the vicinity of the threads, 1908, 1910, 1920, and 1922, the rotary expansion tool 2000 may then be controllably reduced in size until the outside circumference of the expansion cone disengages from the portion of the second tubular above the portion of the second tubular member in the vicinity of the threads. In this manner, only the portions of the first and second tubular members, 1900 and 1912, in the vicinity of the threads, 1908, 1910, 1920, and 1922, are radially expanded and plastically deformed.

[00187] More generally still, as illustrated in Fig. 19, the teachings of the present exemplary embodiments provide a method 2100 of providing a fluid tight seal between a pair of adjacent tubular members in which the location of a fluid leak may be detected in the junction between a pair of adjacent tubular members in step 2102. In an exemplary embodiment, in step 2102, a pressurized fluid may be injected through the adjacent coupled tubular members and the amount, if any, of any fluid leakage through the junctions between the adjacent tubular members monitored.

[00188] If the amount of fluid leakage through the junctions of the adjacent tubular members

exceeds a predetermined amount, then a tubular sleeve may then be coupled to and overlapping the junction between the adjacent tubular members in step 2104. And, finally, in step 2106, the portions of the tubular members proximate the tubular sleeve may then be radially expanded. In this manner, a cost efficient and reliable method for repairing leaks in the junctions between adjacent tubular members may be provided.

[00189] Referring to Fig. 20, in an exemplary embodiment, after radially expanding and plastically deforming the first and second tubular members, 1900 and 1912, and the tubular sleeve 1924, an energy source 2202 may be operably coupled to the second tubular member. The energy source 2202 may include, for example, a source of electrical, acoustic, and/or thermal energy. A controller 2204 may also be operably coupled to the energy source 2202 for controlling the operation of the energy source. In an exemplary embodiment, the first and second tubular members, 1900 and 1912, and the tubular sleeve 1924 are positioned within a borehole 2206 that traverses a subterranean formation 2208, and the energy source 2202 and the controller 2204 are positioned on the surface.

[00190] During operation, electrical, acoustic, and/or thermal energy may then be transmitted through the first and second tubular members, 1900 and 1912, and the tubular sleeve 1924, using the energy source 2202 and controller 2204. In an exemplary embodiment, the first tubular member 1900 may be operably coupled to an earth ground 2206 such as, for example, a subterranean formation. In this manner, the transmission of electrical, acoustic, and/or thermal energy through the tubular members, 1900 and 1912, and the tubular sleeve 1924, may be enhanced. The enhanced coupling of the first and second tubular members, 1900 and 1912, provided by the addition of the tubular sleeve 1924 during the radial expansion process, provides a enhanced conductive pathway for electrical, thermal, and/or acoustic energy.

[00191] In an exemplary embodiment, the transmitted electrical, acoustic, and/or thermal energy may be used, for example, to transmit communication signals to downhole tools, heat the first and second tubular members, 1900 and 1912, and tubular sleeve 1924, and/or to inject energy into the surrounding subterranean formation. In this manner, information may be transmitted through the tubular members, 1900 and 1912, and tubular sleeve 1924 to downhole tools. As will be recognized by persons having ordinary skill in the art, the transmission of an electrical current through the first and second tubular members, 1900 and 1912, will cause resistance heating of the tubular members. In this manner, the surrounding subterranean formation may be heated to thereby facilitate the extraction and recovery of hydrocarbons.

[00192] More generally, the teachings of the exemplary embodiment of Fig. 20 may be applied to one or more of the teachings of the exemplary embodiments of Figs. 1a-19 in order to transmit electrical, acoustic, and/or thermal energy through the corresponding radially expanded and plastically deformed tubular members and sleeves. In particular, the enhanced coupling of the tubular members of the exemplary embodiments of Figs. 1a-19, provided by the addition of the corresponding tubular

sleeves during the radial expansion process, provides an enhanced conductive pathway for the transmission of electrical, thermal and/or acoustic energy through the radially expanded tubular members.

[00193] More generally still, the teachings of Fig. 20 may be applied to the one or more of the teachings of the exemplary embodiments of Figs. 1a-19 in order to transmit electrical, acoustic, and/or thermal energy through the corresponding tubular members and sleeves, prior to the radial expansion and plastic deformation of the tubular members and sleeves. In particular, the enhanced coupling of the tubular members of the exemplary embodiments of Figs. 1a-19, provided by the addition of the corresponding tubular sleeves, prior to the radial expansion process, provides an enhanced conductive pathway for the transmission of electrical, thermal and/or acoustic energy through the radially expanded tubular members.

[00194] Referring to Fig. 21, an exemplary embodiment of a dual well completion system 2300 includes an inner tubing string 2302 and an outer tubing string 2304 that are positioned and supported within a borehole 2306 that traverses a subterranean formation 2308. The inner tubing string 2302 includes a first tubular member 2310 that is threadably coupled to a second tubular member 2312. The inner tubing string 2302 further includes a tubular sleeve 2314 that is coupled to the ends of the first and second tubular members, 2310 and 2312. The outer tubing string 2304 includes a first tubular member 2316 that is threadably coupled to a second tubular member 2318. The outer tubing string 2304 further includes a tubular sleeve 2320 that is coupled to the ends of the first and second tubular members, 2316 and 2318.

[00195] In an exemplary embodiment, the first tubular members, 2310 and 2316, may be any one of the tubular members, 28, 938, 1036, 1128, 1232, 1328, 1430, 1516, 1632, 1716, or 1912, described above with reference to Figs. 1a-20, the second tubular members, 2312 and 2318, may be any of the tubular members, 10, 910, 1010, 1110, 1210, 1310, 1410, 1510, 1610, 1700, or 1900, described above with reference to Figs. 1a-20, and the tubular sleeves, 2314 and 2320, may be any one of the tubular sleeves, 16, 110, 210, 310, 410, 510, 610, 710, 810, 918, 1018, 1116, 1216, 1316, 1418, 1512, 1616, 1732, or 1924, described above with reference to Figs. 1a-20.

[00196] In an exemplary embodiment, the outer tubing string 2304 is positioned within the borehole 2306, with the lower portion of the outer tubing string positioned above and proximate a producing subterranean zone 2322, and radially expanded and plastically deformed as described above with reference to Figs. 1a-20. In an exemplary embodiment, the upper portion of the outer tubing string 2304 is supported, for example, by coupling the upper portion of the outer tubing string to a wellbore casing. The inner tubing string 2302 is then positioned within the borehole 2306, with the lower portion of the inner tubing string positioned above and proximate another producing zone 2324, and radially expanded and plastically deformed as described above with reference to Figs. 1a-20. In an exemplary embodiment, the upper portion of the inner tubing string 2302 is supported, for example, by

coupling the upper portion of the inner tubing string to a wellbore casing. In this manner, an annular flow passage 2326 is defined between the inner and outer tubing strings, 2302 and 2304, and a flow passage 2328 is defined within the inner tubing string. In an exemplary embodiment, conventional packers, 2330 and 2332, are coupled to the lower portions of the outer and inner tubing strings, 2304 and 2302, respectively, for fluidically isolating the producing zones, 2322 and 2324 from one another. Furthermore, the packers, 2330 and 2332, in an exemplary embodiment, also fluidically isolate the annular passage 2326 from the passage 2328, as well as fluidically isolate the annular passage 2326 and the passage 2328 from an annular passage 2334 defined between the outer tubing string 2304 and the borehole 2306.

[00197] During operation of the dual well completion system 2300, fluidic materials within the producing zone 2322 are conveyed out of the borehole 2306 through the annular passage 2326, and fluidic materials within the producing zone 2324 are conveyed out of the borehole through the annular passage 2328. In this manner, the dual well completion system 2300 permits simultaneous and/or separate extraction of fluidic materials from the producing zones, 2322 and 2324. Furthermore, the use of the tubular sleeves, 2314 and 2320, in the inner and outer tubing strings, 2302 and 2304, respectively, permits an increased volumetric flow of fluidic materials through the annular passage 2326 and the passage 2328. In particular, in an exemplary embodiment, the use of the tubular sleeves, 2314 and 2320, in the inner and outer tubing strings, 2302 and 2304, in combination with first and second tubular members, 2310 and 2312 and 2316 and 2318, respectively, having conventional threaded connections, increases the permissible radial clearances between the inner and outer tubing strings thereby increasing the maximum volumetric flow rates through the annular passage 2326 and the passage 2328.

[00198] A method of radially expanding and plastically deforming a first tubular member and a second tubular member has been described that includes inserting an end of the first tubular member into an end of a tubular sleeve having an internal flange into abutment with the internal flange, inserting an end of the second tubular member into another end of the tubular sleeve, threadably coupling the ends of the first and second tubular member within the tubular sleeve until both ends of the first and second tubular members abut the internal flange of the tubular sleeve, and displacing an expansion cone through the interiors of the first and second tubular members. In an exemplary embodiment, the internal flange of the tubular sleeve is positioned between the ends of the tubular sleeve. In an exemplary embodiment, the internal flange of the tubular sleeve is positioned at one end of the tubular sleeve. In an exemplary embodiment, the tubular sleeve further includes one or more sealing members for sealing the interface between the tubular sleeve and at least one of the tubular members. In an exemplary embodiment, the method further includes placing the tubular members in another structure, and displacing the expansion cone through the interiors of the first and second tubular members. In an exemplary embodiment, the method further includes radially expanding the

tubular sleeve into engagement with the structure. In an exemplary embodiment, the method further includes sealing an annulus between the tubular sleeve and the other structure. In an exemplary embodiment, the other structure comprises a wellbore. In an exemplary embodiment, the other structure comprises a wellbore casing. In an exemplary embodiment, the tubular sleeve further comprises a sealing element coupled to the exterior of the tubular sleeve. In an exemplary embodiment, the tubular sleeve is metallic. In an exemplary embodiment, the tubular sleeve is non-metallic. In an exemplary embodiment, the tubular sleeve is plastic. In an exemplary embodiment, the tubular sleeve is ceramic. In an exemplary embodiment, the method further includes breaking the tubular sleeve. In an exemplary embodiment, the tubular sleeve includes one or more longitudinal slots. In an exemplary embodiment, the tubular sleeve includes one or more radial passages.

[00199] A method of radially expanding and plastically deforming a first tubular member and a second tubular member has also been described that includes inserting an end of the first tubular member into an end of a tubular sleeve, coupling the end of the tubular sleeve to the end of the first tubular member, inserting an end of the second tubular member into another end of the tubular sleeve, threadably coupling the ends of the first and second tubular member within the tubular sleeve, coupling the other end of the tubular sleeve to the end of the second tubular member, and displacing an expansion cone through the interiors of the first and second tubular members. In an exemplary embodiment, coupling the ends of the tubular sleeve to the ends of the first and second tubular members includes coupling the ends of the tubular sleeve to the ends of the first and second tubular members using locking rings. In an exemplary embodiment, coupling the ends of the tubular sleeve to the ends of the first and second tubular members using locking rings includes wedging the locking rings between the ends of the tubular sleeve and the ends of the first and second tubular members. In an exemplary embodiment, coupling the ends of the tubular sleeve to the ends of the first and second tubular members using locking rings includes affixing the locking rings to the ends of the first and second tubular members. In an exemplary embodiment, the locking rings are resilient. In an exemplary embodiment, the locking rings are elastomeric. In an exemplary embodiment, coupling the ends of the tubular sleeve to the ends of the first and second tubular members includes crimping the ends of the tubular sleeve onto the ends of the first and second tubular members. In an exemplary embodiment, the tubular sleeve further includes one or more sealing members for sealing the interface between the tubular sleeve and at least one of the tubular members. In an exemplary embodiment, the method further includes placing the tubular members in another structure, and displacing the expansion cone through the interiors of the first and second tubular members. In an exemplary embodiment, the method further includes radially expanding the tubular sleeve into engagement with the structure. In an exemplary embodiment, the method further includes sealing an annulus between the tubular sleeve and the other structure. In an exemplary embodiment, the other structure is a wellbore. In an exemplary embodiment, the other structure is a wellbore casing. In an exemplary embodiment, the

tubular sleeve further includes a sealing element coupled to the exterior of the tubular sleeve. In an exemplary embodiment, the tubular sleeve is metallic. In an exemplary embodiment, the tubular sleeve is non-metallic. In an exemplary embodiment, the tubular sleeve is plastic. In an exemplary embodiment, the tubular sleeve is ceramic. In an exemplary embodiment, the method further includes breaking the tubular sleeve. In an exemplary embodiment, the tubular sleeve includes one or more longitudinal slots. In an exemplary embodiment, the tubular sleeve includes one or more radial passages.

[00200] A method of radially expanding and plastically deforming a first tubular member and a second tubular member has also been described that includes inserting an end of a tubular sleeve having an external flange into an end of the first tubular member until the external flange abuts the end of the first tubular member, inserting the other end of the tubular sleeve into an end of a second tubular member, threadably coupling the ends of the first and second tubular member within the tubular sleeve until both ends of the first and second tubular members abut the external flange of the tubular sleeve, and displacing an expansion cone through the interiors of the first and second tubular members. In an exemplary embodiment, the external flange of the tubular sleeve is positioned between the ends of the tubular sleeve. In an exemplary embodiment, the external flange of the tubular sleeve is positioned at one end of the tubular sleeve. In an exemplary embodiment, the tubular sleeve further includes one or more sealing members for sealing the interface between the tubular sleeve and at least one of the tubular members. In an exemplary embodiment, the method further includes placing the tubular members in another structure, and displacing the expansion cone through the interiors of the first and second tubular members. In an exemplary embodiment, the other structure comprises a wellbore. In an exemplary embodiment, the other structure comprises a wellbore casing. In an exemplary embodiment, the tubular sleeve is metallic. In an exemplary embodiment, the tubular sleeve is non-metallic. In an exemplary embodiment, the tubular sleeve is plastic. In an exemplary embodiment, the tubular sleeve is ceramic. In an exemplary embodiment, the method further includes breaking the tubular sleeve. In an exemplary embodiment, the tubular sleeve includes one or more longitudinal slots. In an exemplary embodiment, the tubular sleeve includes one or more radial passages.

[00201] A method of radially expanding and plastically deforming a first tubular member and a second tubular member has also been described that includes inserting an end of the first tubular member into an end of a tubular sleeve having an internal flange into abutment with the internal flange, inserting an end of the second tubular member into another end of the tubular sleeve into abutment with the internal flange, coupling the ends of the first and second tubular member to the tubular sleeve, and displacing an expansion cone through the interiors of the first and second tubular members. In an exemplary embodiment, the internal flange of the tubular sleeve is positioned between the ends of the tubular sleeve. In an exemplary embodiment, the internal flange of the tubular sleeve is positioned at one end of the tubular sleeve. In an exemplary embodiment, the tubular sleeve further comprises one

or more sealing members for sealing the interface between the tubular sleeve and at least one of the tubular members. In an exemplary embodiment, the method further includes placing the tubular members in another structure, and displacing the expansion cone through the interiors of the first and second tubular members. In an exemplary embodiment, the method further includes radially expanding the tubular sleeve into engagement with the structure. In an exemplary embodiment, the method further includes sealing an annulus between the tubular sleeve and the other structure. In an exemplary embodiment, the other structure is a wellbore. In an exemplary embodiment, the other structure is a wellbore casing. In an exemplary embodiment, the tubular sleeve further includes a sealing element coupled to the exterior of the tubular sleeve. In an exemplary embodiment, the tubular sleeve is metallic. In an exemplary embodiment, the tubular sleeve is non-metallic. In an exemplary embodiment, the tubular sleeve is plastic. In an exemplary embodiment, the tubular sleeve is ceramic. In an exemplary embodiment, the method further includes breaking the tubular sleeve. In an exemplary embodiment, the tubular sleeve includes one or more longitudinal slots. In an exemplary embodiment, the tubular sleeve includes one or more radial passages. In an exemplary embodiment, coupling the ends of the first and second tubular member to the tubular sleeve includes heating the tubular sleeve and inserting the ends of the first and second tubular members into the tubular sleeve. In an exemplary embodiment, coupling the ends of the first and second tubular member to the tubular sleeve includes coupling the tubular sleeve to the ends of the first and second tubular members using a locking ring.

[00202] A method has been described that includes coupling an end of a first tubular member to an end of a tubular sleeve, coupling an end of a second tubular member to another end of the tubular sleeve, coupling the ends of the first and second tubular members, and radially expanding and plastically deforming the first tubular member and the second tubular member. In an exemplary embodiment, the tubular sleeve includes an internal flange. In an exemplary embodiment, coupling the end of the first tubular member to the end of the tubular sleeve includes inserting the end of the first tubular member into the end of the tubular sleeve into abutment with the internal flange. In an exemplary embodiment, coupling the end of the second tubular member to the other end of the tubular sleeve includes inserting the end of the second tubular member into the other end of the tubular sleeve into abutment with the internal flange. In an exemplary embodiment, coupling the end of the second tubular member to the other end of the tubular sleeve includes inserting the end of the second tubular member into the other end of the tubular sleeve into abutment with the internal flange. In an exemplary embodiment, the tubular sleeve includes an external flange. In an exemplary embodiment, coupling the end of the first tubular member to the end of the tubular sleeve includes inserting the end of the tubular sleeve into the end of the first tubular member until the end of the first tubular member abuts the external flange. In an exemplary embodiment, coupling the end of the second tubular member to the other end of the tubular sleeve includes inserting the other end of the tubular sleeve into

the end of the second tubular member until the end of the second tubular member abuts the external flange. In an exemplary embodiment, coupling the end of the second tubular member to the other end of the tubular sleeve includes inserting the other end of the tubular sleeve into the end of the second tubular member until the end of the second tubular member abuts the external flange. In an exemplary embodiment, coupling the end of the first tubular member to the end of the tubular sleeve includes inserting a retaining ring between the end of the first tubular member and the end of the tubular sleeve. In an exemplary embodiment, coupling the end of the second tubular member to the other end of the tubular sleeve includes inserting another retaining ring between the end of the second tubular member and the other end of the tubular sleeve. In an exemplary embodiment, coupling the end of the second tubular member to the other end of the tubular sleeve includes inserting a retaining ring between the end of the first tubular member and the other end of the tubular sleeve. In an exemplary embodiment, the retaining ring is resilient. In an exemplary embodiment, the retaining ring and the other retaining ring are resilient. In an exemplary embodiment, the retaining ring is resilient. In an exemplary embodiment, coupling the end of the first tubular member to the end of the tubular sleeve includes deforming the end of the tubular sleeve. In an exemplary embodiment, coupling the end of the second tubular member to the other end of the tubular sleeve includes deforming the other end of the tubular sleeve. In an exemplary embodiment, coupling the end of the second tubular member to the other end of the tubular sleeve includes deforming the other end of the tubular sleeve. In an exemplary embodiment, coupling the end of the first tubular member to the end of the tubular sleeve includes coupling a retaining ring to the end of the first tubular member. In an exemplary embodiment, coupling the end of the second tubular member to the other end of the tubular sleeve includes coupling another retaining ring to the end of the second tubular member. In an exemplary embodiment, coupling the end of the second tubular member to the other end of the tubular sleeve includes coupling a retaining ring to the end of the second tubular member. In an exemplary embodiment, the retaining ring is resilient. In an exemplary embodiment, the retaining ring and the other retaining ring are resilient. In an exemplary embodiment, the retaining ring is resilient. In an exemplary embodiment, coupling the end of the first tubular member to the end of the tubular sleeve includes heating the end of the tubular sleeve, and inserting the end of the first tubular member into the end of the tubular sleeve. In an exemplary embodiment, coupling the end of the second tubular member to the other end of the tubular sleeve includes heating the other end of the tubular sleeve, and inserting the end of the second tubular member into the other end of the tubular sleeve. In an exemplary embodiment, coupling the end of the second tubular member to the other end of the tubular sleeve includes heating the other end of the tubular sleeve, and inserting the end of the second tubular member into the other end of the tubular sleeve. In an exemplary embodiment, coupling the end of the first tubular member to the end of the tubular sleeve includes inserting the end of the first tubular member into the end of the tubular sleeve, and latching the end of the first tubular member to the end of the tubular sleeve. In an

exemplary embodiment, coupling the end of the second tubular member to the other end of the tubular sleeve includes inserting the end of the second tubular member into the end of the tubular sleeve, and latching the end of the second tubular member to the other end of the tubular sleeve. In an exemplary embodiment, coupling the end of the second tubular member to the other end of the tubular sleeve includes inserting the end of the second tubular member into the end of the tubular sleeve, and latching the end of the second tubular member to the other end of the tubular sleeve. In an exemplary embodiment, the tubular sleeve further comprises one or more sealing members for sealing the interface between the tubular sleeve and at least one of the tubular members. In an exemplary embodiment, the method further includes placing the tubular members in another structure, and then radially expanding and plastically deforming the first tubular member and the second tubular member. In an exemplary embodiment, the method further includes radially expanding the tubular sleeve into engagement with the structure. In an exemplary embodiment, the method further includes sealing an annulus between the tubular sleeve and the other structure. In an exemplary embodiment, the other structure is a wellbore. In an exemplary embodiment, the other structure is a wellbore casing. In an exemplary embodiment, the tubular sleeve further includes a sealing element coupled to the exterior of the tubular sleeve. In an exemplary embodiment, the tubular sleeve is metallic. In an exemplary embodiment, the tubular sleeve is non-metallic. In an exemplary embodiment, the tubular sleeve is plastic. In an exemplary embodiment, the tubular sleeve is ceramic. In an exemplary embodiment, the method further includes breaking the tubular sleeve. In an exemplary embodiment, the tubular sleeve includes one or more longitudinal slots. In an exemplary embodiment, the tubular sleeve includes one or more radial passages. In an exemplary embodiment, radially expanding and plastically deforming the first tubular member, the second tubular member, and the tubular sleeve includes displacing an expansion cone within and relative to the first and second tubular members. In an exemplary embodiment, radially expanding and plastically deforming the first tubular member, the second tubular member, and the tubular sleeve includes applying radial pressure to the interior surfaces of the first and second tubular member using a rotating member. In an exemplary embodiment, the method further includes amorously bonding the first and second tubular members during the radial expansion and plastic deformation of the first and second tubular members. In an exemplary embodiment, the method further includes welding the first and second tubular members during the radial expansion and plastic deformation of the first and second tubular members. In an exemplary embodiment, the method further includes providing a fluid tight seal within the threaded coupling between the first and second tubular members during the radial expansion and plastic deformation of the first and second tubular members. In an exemplary embodiment, the method further includes placing the tubular sleeve in circumferential tension, placing the end of the first tubular member in circumferential compression, and placing the end of the second tubular member in circumferential compression. In an exemplary embodiment, the method further includes placing the tubular sleeve in circumferential compression, placing the end of

the first tubular member in circumferential tension, and placing the end of the second tubular member in circumferential tension. In an exemplary embodiment, radially expanding and plastically deforming the first tubular member and the second tubular member includes radially expanding and plastically deforming only the portions of the first and second members proximate the tubular sleeve. In an exemplary embodiment, the method further includes providing a fluid tight seal between the tubular sleeve and at least one of the first and second tubular members. In an exemplary embodiment, the first tubular member includes internal threads, and the second tubular member includes external threads that engage the internal threads of the first tubular member. In an exemplary embodiment, radially expanding and plastically deforming the first tubular member and the second tubular member includes radially expanding and plastically deforming only the portions of the first and second members proximate the threads of the first and second tubular members. In an exemplary embodiment, the method further includes providing a fluid tight seal between the threads of the first and second tubular members. In an exemplary embodiment, the method further includes providing a fluid tight seal between the tubular sleeve and at least one of the first and second tubular members. In an exemplary embodiment, the first and second tubular members are wellbore casings. In an exemplary embodiment, the first and second tubular members are pipes.

[00203] A method has been described that includes providing a tubular sleeve including an internal flange positioned between the ends of the tubular sleeve, inserting an end of a first tubular member into an end of the tubular sleeve into abutment with the internal flange, inserting an end of a second tubular member into another end of the tubular sleeve into abutment the internal flange, threadably coupling the ends of the first and second tubular members, radially expanding and plastically deforming the first tubular member and the second tubular member, placing the tubular sleeve in circumferential tension, placing the end of the first tubular member in circumferential compression, and placing the end of the second tubular member in circumferential compression.

[00204] A method has been described that includes providing a tubular sleeve including an external flange positioned between the ends of the tubular sleeve, inserting an end of the tubular sleeve into an end of a first tubular member until the end of the first tubular member abuts with the external flange, inserting another end of the tubular sleeve into an end of the second tubular member until the end of the second tubular member abuts the external flange, threadably coupling the ends of the first and second tubular members, radially expanding and plastically deforming the first tubular member and the second tubular member, placing the tubular sleeve in circumferential compression, placing the end of the first tubular member in circumferential tension, and placing the end of the second tubular member in circumferential tension.

[00205] A method has been described that includes providing a tubular sleeve including an internal flange positioned between the ends of the tubular sleeve, inserting an end of a first tubular member into an end of the tubular sleeve into abutment with the internal flange, inserting an end of a second tubular

member into another end of the tubular sleeve into abutment the internal flange, threadably coupling the ends of the first and second tubular members, radially expanding and plastically deforming only the portions of the first tubular member and the second tubular member proximate the threads of the first and second tubular members, placing the tubular sleeve in circumferential tension, placing the end of the first tubular member in circumferential compression, and placing the end of the second tubular member in circumferential compression.

[00206] A method has been described that includes providing a tubular sleeve including an external flange positioned between the ends of the tubular sleeve, inserting an end of the tubular sleeve into an end of a first tubular member until the end of the first tubular member abuts with the external flange, inserting another end of the tubular sleeve into an end of the second tubular member until the end of the second tubular member abuts the external flange, threadably coupling the ends of the first and second tubular members, radially expanding and plastically deforming only the portions of the first tubular member and the second tubular member proximate the threads of the first and second tubular members, placing the tubular sleeve in circumferential compression, placing the end of the first tubular member in circumferential tension, and placing the end of the second tubular member in circumferential tension.

[00207] An apparatus has been described that includes a tubular sleeve, a first tubular member coupled to an end of the tubular sleeve, and a second tubular member coupled to another end of the tubular sleeve. In an exemplary embodiment, the tubular sleeve is in circumferential tension, the end portion of the first tubular member is in circumferential compression, and the end portion of the second tubular member is in circumferential compression. In an exemplary embodiment, the tubular sleeve is in circumferential compression, the end portion of the first tubular member is in circumferential tension, and the end portion of the second tubular member is in circumferential tension. In an exemplary embodiment, the tubular sleeve includes an internal flange. In an exemplary embodiment, the end portion of the first tubular member is received within an end of the tubular sleeve, and the end portion of the second tubular member is received within another end of the tubular sleeve. In an exemplary embodiment, the end portions of the first and second tubular members abut the internal flange of the tubular sleeve. In an exemplary embodiment, the end portion of the first tubular member is received within an end of the tubular sleeve. In an exemplary embodiment, the end portions of the first and second tubular members abut the internal flange of the tubular sleeve. In an exemplary embodiment, the end portion of the second tubular member is received within an end of the tubular sleeve. In an exemplary embodiment, the end portions of the first and second tubular members abut the internal flange of the tubular sleeve. In an exemplary embodiment, the internal flange of the tubular sleeve is positioned between the ends of the tubular sleeve. In an exemplary embodiment, the internal flange of the tubular sleeve is positioned at an end of the tubular sleeve. In an exemplary embodiment, the tubular sleeve includes an external flange. In an exemplary embodiment, an end

portion of the tubular sleeve is received within the first tubular member; and another end portion of the tubular sleeve is received within the end portion of the second tubular member. In an exemplary embodiment, the end portions of the first and second tubular members abut the external flange of the tubular sleeve. In an exemplary embodiment, an end portion of the tubular sleeve is received within the end portion of the first tubular member. In an exemplary embodiment, the end portions of the first and second tubular members abut the external flange of the tubular sleeve. In an exemplary embodiment, an end portion of the tubular sleeve is received within the end portion of the second tubular member. In an exemplary embodiment, the end portions of the first and second tubular members abut the external flange of the tubular sleeve. In an exemplary embodiment, the external flange of the tubular sleeve is positioned between the ends of the tubular sleeve. In an exemplary embodiment, the external flange of the tubular sleeve is positioned at an end of the tubular sleeve. In an exemplary embodiment, the tubular sleeve further comprises one or more sealing members for sealing the interface between the tubular sleeve and at least one of the tubular members. In an exemplary embodiment, the apparatus further includes a retaining ring positioned between the end of the first tubular member and the end of the tubular sleeve. In an exemplary embodiment, the apparatus further includes another retaining ring positioned between the end of the second tubular member and the other end of the tubular sleeve. In an exemplary embodiment, the apparatus further includes a retaining ring positioned between the end of the first tubular member and the other end of the tubular sleeve. In an exemplary embodiment, the retaining ring is resilient. In an exemplary embodiment, the retaining ring and the other retaining ring are resilient. In an exemplary embodiment, the retaining ring is resilient. In an exemplary embodiment, the end of the tubular sleeve is deformed onto the end of the first tubular member. In an exemplary embodiment, the other end of the tubular sleeve is deformed onto the end of the second tubular member. In an exemplary embodiment, the other end of the tubular sleeve is deformed onto the end of the second tubular member. In an exemplary embodiment, the apparatus further includes a retaining ring coupled to the end of the first tubular member for retaining the tubular sleeve onto the end of the first tubular member. In an exemplary embodiment, the apparatus further includes another retaining ring coupled to the end of the second tubular member for retaining the other end of the tubular sleeve onto the end of the second tubular member. In an exemplary embodiment, the apparatus further includes a retaining ring coupled to the end of the second tubular member for retaining the other end of the tubular sleeve onto the end of the second tubular member. In an exemplary embodiment, the retaining ring is resilient. In an exemplary embodiment, the retaining ring and the other retaining ring are resilient. In an exemplary embodiment, the retaining ring is resilient. In an exemplary embodiment, the apparatus further includes a locking ring for coupling the end of the first tubular member to the end of the tubular sleeve. In an exemplary embodiment, the apparatus further includes another locking ring for coupling the end of the second tubular member to the other end of the tubular sleeve. In an exemplary embodiment, the apparatus

further includes a locking ring for coupling the end of the second tubular member to the other end of the tubular sleeve. In an exemplary embodiment, the apparatus further includes a structure for receiving the first and second tubular members and the tubular sleeve, and the tubular sleeve contacts the interior surface of the structure. In an exemplary embodiment, the tubular sleeve further includes a sealing member for fluidically sealing the interface between the tubular sleeve and the structure. In an exemplary embodiment, the other structure is a wellbore. In an exemplary embodiment, the other structure is a wellbore casing. In an exemplary embodiment, the tubular sleeve further includes a sealing element coupled to the exterior surface of the tubular sleeve. In an exemplary embodiment, the tubular sleeve is metallic. In an exemplary embodiment, the tubular sleeve is non-metallic. In an exemplary embodiment, the tubular sleeve is plastic. In an exemplary embodiment, the tubular sleeve is ceramic. In an exemplary embodiment, the tubular sleeve is frangible. In an exemplary embodiment, the tubular sleeve includes one or more longitudinal slots. In an exemplary embodiment, the tubular sleeve includes one or more radial passages. In an exemplary embodiment, the first and second tubular members are amorphously bonded. In an exemplary embodiment, the first and second tubular members are welded. In an exemplary embodiment, the internal threads of the first tubular member and the internal threads of the second tubular member together provide a fluid tight seal. In an exemplary embodiment, only the portions of the first and second tubular members proximate the tubular sleeve are plastically deformed. In an exemplary embodiment, a fluid tight seal is provided between the tubular sleeve and at least one of the first and second tubular members. In an exemplary embodiment, the first tubular member includes internal threads; and wherein the second tubular member includes external threads that engage the internal threads of the first tubular member. In an exemplary embodiment, only the portions of the first and second members proximate the threads of the first and second tubular members are plastically deformed. In an exemplary embodiment, a fluid tight seal is provided between the threads of the first and second tubular members. In an exemplary embodiment, a fluid tight seal is provided between the tubular sleeve and at least one of the first and second tubular members.

[00208] An apparatus has been described that includes a tubular sleeve including an internal flange positioned between the ends of the tubular sleeve, a first tubular member received within an end of the tubular sleeve in abutment with the internal flange that comprises internal threads, and a second tubular member received within another end of the tubular sleeve in abutment with the internal flange that comprises external threads that engage the internal threads of the first tubular member. The tubular sleeve is in circumferential tension, the end of first tubular member is in circumferential compression, and the end of the second tubular member is in circumferential compression.

[00209] An apparatus has been described that includes a tubular sleeve comprising an external flange positioned between the ends of the tubular sleeve, a first tubular member that receives an end of the tubular sleeve and abuts the external flange that comprises internal threads, and a second tubular

member that receives another end of the tubular sleeve that abuts the external flange that comprises external threads that engage the internal threads of the first tubular member. The tubular sleeve is in circumferential compression, the first tubular member is in circumferential tension, and the second tubular member is in circumferential tension.

[00210] An apparatus has been described that includes a tubular sleeve comprising an internal flange positioned between the ends of the tubular sleeve, a first tubular member received within an end of the tubular sleeve in abutment with the internal flange that comprises internal threads, and a second tubular member received within another end of the tubular sleeve in abutment with the internal flange that comprises external threads that engage the internal threads of the first tubular member. The tubular sleeve is in circumferential tension, the end of first tubular member is in circumferential compression, the end of the second tubular member is in circumferential compression, a fluid tight seal is provided between the tubular sleeve and at least one of the first and second tubular members, and a fluid tight seal is provided between the threads of the first and second tubular members.

[00211] An apparatus has been described that includes a tubular sleeve comprising an external flange positioned between the ends of the tubular sleeve, a first tubular member that receives an end of the tubular sleeve and abuts the external flange that comprises internal threads, and a second tubular member that receives another end of the tubular sleeve that abuts the external flange that comprises external threads that engage the internal threads of the first tubular member. The tubular sleeve is in circumferential compression, the first tubular member is in circumferential tension, the second tubular member is in circumferential tension, a fluid tight seal is provided between the tubular sleeve and at least one of the first and second tubular members, and a fluid tight seal is provided between the threads of the first and second tubular members.

[00212] A method of extracting geothermal energy from a subterranean source of geothermal energy has been described that includes drilling a borehole that traverses the subterranean source of geothermal energy, positioning a first casing string within the borehole, radially expanding and plastically deforming the first casing string within the borehole, positioning a second casing string within the borehole that traverses the subterranean source of geothermal energy, overlapping a portion of the second casing string with a portion of the first casing string, radially expanding and plastically deforming the second casing string within the borehole, and extracting geothermal energy from the subterranean source of geothermal energy using the first and second casing strings. In an exemplary embodiment, the interior diameter of a passage defined by the first and second casing strings is constant. In an exemplary embodiment, at least one of the first and second casing strings includes a tubular sleeve, a first tubular member coupled to an end of the tubular sleeve comprising internal threads at an end portion, and a second tubular member coupled to another end of the tubular sleeve comprising external threads at an end portion that engage the internal threads of the end portion of the first tubular member.

[00213] A method of extracting geothermal energy from a subterranean source of geothermal energy has been described that includes drilling a borehole that traverses the subterranean source of geothermal energy, positioning a first casing string within the borehole, radially expanding and plastically deforming the first casing string within the borehole, positioning a second casing string within the borehole that traverses the subterranean source of geothermal energy, overlapping a portion of the second casing string with a portion of the first casing string, radially expanding and plastically deforming the second casing string within the borehole, and extracting geothermal energy from the subterranean source of geothermal energy using the first and second casing strings. The interior diameter of a passage defined by the first and second casing strings is constant, and at least one of the first and second casing strings includes a tubular sleeve comprising an internal flange positioned between the ends of the tubular sleeve, a first tubular member received within an end of the tubular sleeve in abutment with the internal flange that comprises internal threads, and a second tubular member received within another end of the tubular sleeve in abutment with the internal flange that comprises external threads that engage the internal threads of the first tubular member.

[00214] A method of extracting geothermal energy from a subterranean source of geothermal energy has been described that includes drilling a borehole that traverses the subterranean source of geothermal energy, positioning a first casing string within the borehole, radially expanding and plastically deforming the first casing string within the borehole, positioning a second casing string within the borehole that traverses the subterranean source of geothermal energy, overlapping a portion of the second casing string with a portion of the first casing string, radially expanding and plastically deforming the second casing string within the borehole, and extracting geothermal energy from the subterranean source of geothermal energy using the first and second casing strings. The interior diameter of a passage defined by the first and second casing strings is constant, and at least one of the first and second casing strings include: a tubular sleeve comprising an external flange positioned between the ends of the tubular sleeve, a first tubular member that receives an end of the tubular sleeve that abuts external flange that comprises internal threads, and a second tubular member that receives another end of the tubular sleeve that abuts the external flange that comprises external threads that engage the internal threads of the first tubular member.

[00215] A method of extracting geothermal energy from a subterranean source of geothermal energy has been described that includes drilling a borehole that traverses the subterranean source of geothermal energy, positioning a first casing string within the borehole, radially expanding and plastically deforming the first casing string within the borehole, positioning a second casing string within the borehole that traverses the subterranean source of geothermal energy, overlapping a portion of the second casing string with a portion of the first casing string, radially expanding and plastically deforming the second casing string within the borehole, and extracting geothermal energy from the subterranean source of geothermal energy using the first and second casing strings. The interior

diameter of a passage defined by the first and second casing strings is constant, and at least one of the first and second casing strings include a tubular sleeve comprising an internal flange positioned between the ends of the tubular sleeve, a first tubular member received within an end of the tubular sleeve in abutment with the internal flange that comprises internal threads, and a second tubular member received within another end of the tubular sleeve in abutment with the internal flange that comprises external threads that engage the internal threads of the first tubular member. The tubular sleeve is in circumferential tension, the first tubular member is in circumferential compression, the second tubular member is in circumferential compression, a fluid tight seal is provided between the tubular sleeve and at least one of the first and second tubular members, and a fluid tight seal is provided between the threads of the first and second tubular members.

[00216] A method of extracting geothermal energy from a subterranean source of geothermal energy has been described that includes drilling a borehole that traverses the subterranean source of geothermal energy, positioning a first casing string within the borehole, radially expanding and plastically deforming the first casing string within the borehole, positioning a second casing string within the borehole that traverses the subterranean source of geothermal energy, overlapping a portion of the second casing string with a portion of the first casing string, radially expanding and plastically deforming the second casing string within the borehole, and extracting geothermal energy from the subterranean source of geothermal energy using the first and second casing strings. The interior diameter of a passage defined by the first and second casing strings is constant, and wherein at least one of the first and second casing strings include a tubular sleeve comprising an external flange positioned between the ends of the tubular sleeve, a first tubular member that receives an end of the tubular sleeve that abuts external flange that comprises internal threads, and a second tubular member that receives another end of the tubular sleeve that abuts the external flange that comprises external threads that engage the internal threads of the first tubular member. The tubular sleeve is in circumferential compression, the first tubular member is in circumferential tension, the second tubular member is in circumferential tension, a fluid tight seal is provided between the tubular sleeve and at least one of the first and second tubular members, and a fluid tight seal is provided between the threads of the first and second tubular members.

[00217] An apparatus for extracting geothermal energy from a subterranean source of geothermal energy has been described that includes a borehole that traverses the subterranean source of geothermal energy, a first casing string positioned within the borehole, and a second casing positioned within the borehole that overlaps with the first casing string that traverses the subterranean source of geothermal energy. The first casing string and the second casing string are radially expanded and plastically deformed within the borehole. In an exemplary embodiment, the interior diameter of a passage defined by the first and second casing strings is constant. In an exemplary embodiment, at least one of the first and second casing strings include a tubular sleeve, a first tubular member coupled to an end of the

tubular sleeve comprising internal threads at an end portion, and a second tubular member coupled to another end of the tubular sleeve comprising external threads at an end portion that engage the internal threads of the end portion of the first tubular member.

[00218] An apparatus for extracting geothermal energy from a subterranean source of geothermal energy has been described that includes a borehole that traverses the subterranean source of geothermal energy, a first casing string positioned within the borehole, a second casing string within the borehole that traverses the subterranean source of geothermal energy that overlaps with the first casing string. The first and second casing strings are radially expanded and plastically deformed within the borehole, the inside diameter of a passage defined by the first and second casing strings is constant, and at least one of the first and second casing strings includes a tubular sleeve comprising an internal flange positioned between the ends of the tubular sleeve, a first tubular member received within an end of the tubular sleeve in abutment with the internal flange that comprises internal threads, and a second tubular member received within another end of the tubular sleeve in abutment with the internal flange that comprises external threads that engage the internal threads of the first tubular member.

[00219] An apparatus for extracting geothermal energy from a subterranean source of geothermal energy has been described a borehole that traverses the subterranean source of geothermal energy, a first casing string positioned within the borehole, and a second casing string positioned within the borehole that traverses the subterranean source of geothermal energy that overlaps with the first casing string. The interior diameter of a passage defined by the first and second casing strings is constant, and wherein at least one of the first and second casing strings include: a tubular sleeve comprising an external flange positioned between the ends of the tubular sleeve, a first tubular member that receives an end of the tubular sleeve that abuts external flange that comprises internal threads, and a second tubular member that receives another end of the tubular sleeve that abuts the external flange that comprises external threads that engage the internal threads of the first tubular member.

[00220] An apparatus for extracting geothermal energy from a subterranean source of geothermal energy has been described that includes a borehole that traverses the subterranean source of geothermal energy, a first casing string positioned within the borehole, and a second casing string within the borehole that traverses the subterranean source of geothermal energy that overlaps with the first casing string. The first and second casing strings are radially expanded and plastically deformed within the borehole. The inside diameter of a passage defined by the first and second casing strings is constant, and at least one of the first and second casing strings include: a tubular sleeve comprising an internal flange positioned between the ends of the tubular sleeve, a first tubular member received within an end of the tubular sleeve in abutment with the internal flange that comprises internal threads, a second tubular member received within another end of the tubular sleeve in abutment with the internal flange that comprises external threads that engage the internal threads of the first tubular member, the tubular sleeve is in circumferential tension, the first tubular member is in circumferential compression, the

second tubular member is in circumferential compression, a fluid tight seal is provided between the tubular sleeve and at least one of the first and second tubular members, and a fluid tight seal is provided between the threads of the first and second tubular members.

[00221] An apparatus for extracting geothermal energy from a subterranean source of geothermal energy has been described that includes a borehole that traverses the subterranean source of geothermal energy, a first casing string positioned within the borehole, and a second casing string positioned within the borehole that traverses the subterranean source of geothermal energy that overlaps with the first casing string. The interior diameter of a passage defined by the first and second casing strings is constant, and at least one of the first and second casing strings include: a tubular sleeve comprising an external flange positioned between the ends of the tubular sleeve, a first tubular member that receives an end of the tubular sleeve that abuts external flange that comprises internal threads, and a second tubular member that receives another end of the tubular sleeve that abuts the external flange that comprises external threads that engage the internal threads of the first tubular member. The tubular sleeve is in circumferential compression, the first tubular member is in circumferential tension, the second tubular member is in circumferential tension, a fluid tight seal is provided between the tubular sleeve and at least one of the first and second tubular members, and a fluid tight seal is provided between the threads of the first and second tubular members.

[00222] A method has been described that includes coupling an end of a first tubular member to an end of a tubular sleeve, coupling an end of a second tubular member to another end of the tubular sleeve, coupling the ends of the first and second tubular members, injecting a pressurized fluid through the first and second tubular members, determining if any of the pressurized fluid leaks through the coupled ends of the first and second tubular members, and if a predetermined amount of the pressurized fluid leaks through the coupled ends of the first and second tubular members, then coupling a tubular sleeve to the ends of the first and second tubular members and radially expanding and plastically deforming only the portions of the first and second tubular members proximate the tubular sleeve. In an exemplary embodiment, radially expanding and plastically deforming only the portions of the first and second tubular members proximate the tubular sleeve includes displacing an expansion cone within and relative to the first and second tubular members. In an exemplary embodiment, radially expanding and plastically deforming only the portions of the first and second tubular members proximate the tubular sleeve includes applying radial pressure to the interior surfaces of the first and second tubular member proximate the tubular sleeve using a rotating member.

[00223] A method has been described that includes coupling an end of a first tubular member to an end of a tubular sleeve, coupling an end of a second tubular member to another end of the tubular sleeve, coupling the ends of the first and second tubular members, radially expanding and plastically deforming the first tubular member and the second tubular member, and transmitting energy through the first and second tubular members. In an exemplary embodiment, the energy is electrical energy. In

an exemplary embodiment, the electrical energy is a communication signal. In an exemplary embodiment, the energy is thermal energy. In an exemplary embodiment, the energy is acoustic energy. In an exemplary embodiment, the energy is transmitted through the first and second tubular members prior to radially expanding and plastically deforming the first and second tubular members. In an exemplary embodiment, the energy is transmitted through the first and second tubular members after radially expanding and plastically deforming the first and second tubular members. In an exemplary embodiment, the method further includes placing the tubular members in another structure, then radially expanding the tubular members, and transmitting energy through the first and second tubular members.

[00224] A system has been described that includes a source of energy, a borehole formed in the earth, a first tubular member positioned within the borehole operably coupled to the source of energy, a second tubular member positioned within the borehole coupled to the first tubular member, and a tubular sleeve positioned within the borehole coupled to the first and second tubular members. The first tubular member, second tubular member, and the tubular sleeve are plastically deformed into engagement with one another. In an exemplary embodiment, the source of energy is a source of electrical energy. In an exemplary embodiment, the source of energy is a source of thermal energy. In an exemplary embodiment, the source of energy is a source of acoustic energy.

[00225] A method of operating a well for extracting hydrocarbons from a subterranean formation has been described that includes drilling a borehole into the earth that traverses the subterranean formation, positioning a wellbore casing in the borehole, transmitting energy through the wellbore casing, and extracting hydrocarbons from the subterranean formation. The wellbore casing includes a first tubular member, a second tubular member coupled to the first tubular member, and a tubular sleeve coupled to the first and second tubular member. The first tubular member, the second tubular member, and the tubular sleeve are plastically deformed into engagement with one another. In an exemplary embodiment, the energy is electrical energy. In an exemplary embodiment, the energy is thermal energy. In an exemplary embodiment, the energy is acoustic energy.

[00226] A method of extracting fluidic materials from first and second producing subterranean formations traversed by a borehole has been described that includes coupling an end of a first tubular member to an end of a tubular sleeve, coupling an end of a second tubular member to another end of the first tubular sleeve, coupling the ends of the first and second tubular members, positioning the coupled first tubular member, second tubular member and first tubular sleeve within the borehole proximate the first producing subterranean formation, radially expanding and plastically deforming the first tubular member, the second tubular member, and the first tubular sleeve within the borehole, coupling an end of a third tubular member to an end of a second tubular sleeve, coupling an end of a fourth tubular member to another end of the second tubular sleeve, coupling the ends of the third and fourth tubular members, positioning the coupled third tubular member, fourth tubular member and

second tubular sleeve within the radially expanded and coupled first tubular member, second tubular member, and first tubular sleeve and the borehole proximate the second producing subterranean formation, radially expanding and plastically deforming the third tubular member, the fourth tubular member, and the second tubular sleeve within the borehole, extracting fluidic materials from the first producing subterranean formation through an annular passage defined between the radially expanded and coupled first tubular member, second tubular member, and first tubular sleeve and the radially expanded and coupled third tubular member, fourth tubular member, and second tubular sleeve, and extracting fluidic materials from the second producing subterranean formation through a passage defined within the radially expanded and coupled third tubular member, fourth tubular member, and second tubular sleeve. In an exemplary embodiment, the method further includes fluidically sealing an annular passage defined between the radially expanded and coupled first tubular member, second tubular member, and first tubular sleeve and the borehole, and fluidically sealing an annular passage defined between the radially expanded and coupled third tubular member, fourth tubular member, and second tubular sleeve and the borehole.

[00227] A system for extracting fluidic materials from first and second producing subterranean formations traversed by a borehole has been described that includes means for coupling an end of a first tubular member to an end of a tubular sleeve, means for coupling an end of a second tubular member to another end of the first tubular sleeve, means for coupling the ends of the first and second tubular members, means for positioning the coupled first tubular member, second tubular member and first tubular sleeve within the borehole proximate the first producing subterranean formation, means for radially expanding and plastically deforming the first tubular member, the second tubular member, and the first tubular sleeve within the borehole, means for coupling an end of a third tubular member to an end of a second tubular sleeve, means for coupling an end of a fourth tubular member to another end of the second tubular sleeve, means for coupling the ends of the third and fourth tubular members, means for positioning the coupled third tubular member, fourth tubular member and second tubular sleeve within the radially expanded and coupled first tubular member, second tubular member, and first tubular sleeve and the borehole proximate the second producing subterranean formation, means for radially expanding and plastically deforming the third tubular member, the fourth tubular member, and the second tubular sleeve within the borehole, means for extracting fluidic materials from the first producing subterranean formation through an annular passage defined between the radially expanded and coupled first tubular member, second tubular member, and first tubular sleeve and the radially expanded and coupled third tubular member, fourth tubular member, and second tubular sleeve, and means for extracting fluidic materials from the second producing subterranean formation through a passage defined within the radially expanded and coupled third tubular member, fourth tubular member, and second tubular sleeve. In an exemplary embodiment, the system further includes means for fluidically sealing an annular passage defined between the radially expanded and coupled first tubular

member, second tubular member, and first tubular sleeve and the borehole, and means for fluidically sealing an annular passage defined between the radially expanded and coupled third tubular member, fourth tubular member, and second tubular sleeve and the borehole.

[00228] It is understood that variations may be made in the foregoing without departing from the scope of the invention. For example, the teachings of the present illustrative embodiments may be used to provide a wellbore casing, a pipeline, or a structural support. Furthermore, the elements and teachings of the various illustrative embodiments may be combined in whole or in part in some or all of the illustrative embodiments.

[00229] Although illustrative embodiments of the invention have been shown and described, a wide range of modification, changes and substitution is contemplated in the foregoing disclosure. In some instances, some features of the present invention may be employed without a corresponding use of the other features. Accordingly, it is appropriate that the appended claims be construed broadly and in a manner consistent with the scope of the invention.

Claims

What is claimed is:

1. A method, comprising:
coupling an end of a first tubular member to an end of a tubular sleeve;
coupling an end of a second tubular member to another end of the tubular sleeve;
coupling the ends of the first and second tubular members; and
radially expanding and plastically deforming the first tubular member and the second tubular member.
2. The method of claim 1, wherein the tubular sleeve comprises an internal flange.
3. The method of claim 2, wherein coupling the end of the first tubular member to the end of the tubular sleeve comprises:
inserting the end of the first tubular member into the end of the tubular sleeve into abutment with the internal flange.
4. The method of claim 3, wherein coupling the end of the second tubular member to the other end of the tubular sleeve comprises:
inserting the end of the second tubular member into the other end of the tubular sleeve into abutment with the internal flange.
5. The method of claim 2, wherein coupling the end of the second tubular member to the other end of the tubular sleeve comprises:
inserting the end of the second tubular member into the other end of the tubular sleeve into abutment with the internal flange.
6. The method of claim 1, wherein the tubular sleeve comprises an external flange.
7. The method of claim 6, wherein coupling the end of the first tubular member to the end of the tubular sleeve comprises:
inserting the end of the tubular sleeve into the end of the first tubular member until the end of the first tubular member abuts the external flange.
8. The method of claim 7, wherein coupling the end of the second tubular member to the other end of the tubular sleeve comprises:
inserting the other end of the tubular sleeve into the end of the second tubular member until the end of the second tubular member abuts the external flange.
9. The method of claim 6, wherein coupling the end of the second tubular member to the other end of the tubular sleeve comprises:
inserting the other end of the tubular sleeve into the end of the second tubular member until the end of the second tubular member abuts the external flange.
10. The method of claim 1, wherein coupling the end of the first tubular member to the end of the tubular sleeve comprises:

inserting a retaining ring between the end of the first tubular member and the end of the tubular sleeve.

11. The method of claim 10, wherein coupling the end of the second tubular member to the other end of the tubular sleeve comprises:
 - inserting another retaining ring between the end of the second tubular member and the other end of the tubular sleeve.
12. The method of claim 1, wherein coupling the end of the second tubular member to the other end of the tubular sleeve comprises:
 - inserting a retaining ring between the end of the first tubular member and the other end of the tubular sleeve.
13. The method of claim 10, wherein the retaining ring is resilient.
14. The method of claim 11, wherein the retaining ring and the other retaining ring are resilient.
15. The method of claim 12, wherein the retaining ring is resilient.
16. The method of claim 1, wherein coupling the end of the first tubular member to the end of the tubular sleeve comprises:
 - deforming the end of the tubular sleeve.
17. The method of claim 16, wherein coupling the end of the second tubular member to the other end of the tubular sleeve comprises:
 - deforming the other end of the tubular sleeve.
18. The method of claim 1, wherein coupling the end of the second tubular member to the other end of the tubular sleeve comprises:
 - deforming the other end of the tubular sleeve.
19. The method of claim 1, wherein coupling the end of the first tubular member to the end of the tubular sleeve comprises:
 - coupling a retaining ring to the end of the first tubular member.
20. The method of claim 19, wherein coupling the end of the second tubular member to the other end of the tubular sleeve comprises:
 - coupling another retaining ring to the end of the second tubular member.
21. The method of claim 1, wherein coupling the end of the second tubular member to the other end of the tubular sleeve comprises:
 - coupling a retaining ring to the end of the second tubular member.
22. The method of claim 19, wherein the retaining ring is resilient.
23. The method of claim 20, wherein the retaining ring and the other retaining ring are resilient.
24. The method of claim 21, wherein the retaining ring is resilient.
25. The method of claim 1, wherein coupling the end of the first tubular member to the end of the tubular sleeve comprises:

- heating the end of the tubular sleeve; and
inserting the end of the first tubular member into the end of the tubular sleeve.
26. The method of claim 25, wherein coupling the end of the second tubular member to the other end of the tubular sleeve comprises:
heating the other end of the tubular sleeve; and
inserting the end of the second tubular member into the other end of the tubular sleeve.
27. The method of claim 1, wherein coupling the end of the second tubular member to the other end of the tubular sleeve comprises:
heating the other end of the tubular sleeve; and
inserting the end of the second tubular member into the other end of the tubular sleeve.
28. The method of claim 1, wherein coupling the end of the first tubular member to the end of the tubular sleeve comprises:
inserting the end of the first tubular member into the end of the tubular sleeve; and
latching the end of the first tubular member to the end of the tubular sleeve.
29. The method of claim 28, wherein coupling the end of the second tubular member to the other end of the tubular sleeve comprises:
inserting the end of the second tubular member into the end of the tubular sleeve; and
latching the end of the second tubular member to the other end of the tubular sleeve.
30. The method of claim 1, wherein coupling the end of the second tubular member to the other end of the tubular sleeve comprises:
inserting the end of the second tubular member into the end of the tubular sleeve; and
latching the end of the second tubular member to the other end of the tubular sleeve.
31. The method of claim 1, wherein the tubular sleeve further comprises one or more sealing members for sealing the interface between the tubular sleeve and at least one of the tubular members.
32. The method of claim 1, further comprising:
placing the tubular members in another structure; and
then radially expanding and plastically deforming the first tubular member and the second tubular member.
33. The method of claim 32, further comprising:
radially expanding the tubular sleeve into engagement with the structure.
34. The method of claim 32, further comprising:
sealing an annulus between the tubular sleeve and the other structure.
35. The method of claim 32, wherein the other structure comprises a wellbore.
36. The method of claim 32, wherein the other structure comprises a wellbore casing.
37. The method of claim 1, wherein the tubular sleeve further comprises a sealing element coupled to the exterior of the tubular sleeve.

38. The method of claim 1, wherein the tubular sleeve is metallic.
39. The method of claim 1, wherein the tubular sleeve is non-metallic.
40. The method of claim 1, wherein the tubular sleeve is plastic.
41. The method of claim 1, wherein the tubular sleeve is ceramic.
42. The method of claim 1, further comprising:
breaking the tubular sleeve.
43. The method of claim 1, wherein the tubular sleeve includes one or more longitudinal slots.
44. The method of claim 1, wherein the tubular sleeve includes one or more radial passages.
45. The method of claim 1, wherein radially expanding and plastically deforming the first tubular member, the second tubular member, and the tubular sleeve comprises:
displacing an expansion cone within and relative to the first and second tubular members.
46. The method of claim 1, wherein radially expanding and plastically deforming the first tubular member, the second tubular member, and the tubular sleeve comprises:
applying radial pressure to the interior surfaces of the first and second tubular member using a rotating member.
47. The method of claim 1, further comprising:
amorphously bonding the first and second tubular members during the radial expansion and plastic deformation of the first and second tubular members.
48. The method of claim 1, further comprising:
welding the first and second tubular members during the radial expansion and plastic deformation of the first and second tubular members.
49. The method of claim 1, further comprising:
providing a fluid tight seal within the threaded coupling between the first and second tubular members during the radial expansion and plastic deformation of the first and second tubular members.
50. The method of claim 1, further comprising:
placing the tubular sleeve in circumferential tension;
placing the end of the first tubular member in circumferential compression; and
placing the end of the second tubular member in circumferential compression.
51. The method of claim 1, further comprising:
placing the tubular sleeve in circumferential compression;
placing the end of the first tubular member in circumferential tension; and
placing the end of the second tubular member in circumferential tension.
52. The method of claim 1, wherein radially expanding and plastically deforming the first tubular member and the second tubular member comprises:
radially expanding and plastically deforming only the portions of the first and second members

- proximate the tubular sleeve.
53. The method of claim 52, further comprising:
providing a fluid tight seal between the tubular sleeve and at least one of the first and second tubular members.
54. The method of claim 1, wherein the first tubular member comprises internal threads; and wherein the second tubular member comprises external threads that engage the internal threads of the first tubular member.
55. The method of claim 54, wherein radially expanding and plastically deforming the first tubular member and the second tubular member comprises:
radially expanding and plastically deforming only the portions of the first and second members proximate the threads of the first and second tubular members.
56. The method of claim 55, further comprising:
providing a fluid tight seal between the threads of the first and second tubular members.
57. The method of claim 55, further comprising:
providing a fluid tight seal between the tubular sleeve and at least one of the first and second tubular members.
58. The method of claim 1, wherein the first and second tubular members comprise wellbore casings.
59. The method of claim 1, wherein the first and second tubular members comprise pipes.
60. A method, comprising:
providing a tubular sleeve comprising an internal flange positioned between the ends of the tubular sleeve;
inserting an end of a first tubular member into an end of the tubular sleeve into abutment with the internal flange;
inserting an end of a second tubular member into another end of the tubular sleeve into abutment the internal flange;
threadably coupling the ends of the first and second tubular members;
radially expanding and plastically deforming the first tubular member and the second tubular member;
placing the tubular sleeve in circumferential tension;
placing the end of the first tubular member in circumferential compression; and
placing the end of the second tubular member in circumferential compression.
61. A method, comprising:
providing a tubular sleeve comprising an external flange positioned between the ends of the tubular sleeve;
inserting an end of the tubular sleeve into an end of a first tubular member until the end of the

first tubular member abuts with the external flange;
inserting another end of the tubular sleeve into an end of the second tubular member until the
end of the second tubular member abuts the external flange;
threadably coupling the ends of the first and second tubular members;
radially expanding and plastically deforming the first tubular member and the second tubular
member;
placing the tubular sleeve in circumferential compression;
placing the end of the first tubular member in circumferential tension; and
placing the end of the second tubular member in circumferential tension.

62. A method, comprising:
providing a tubular sleeve comprising an internal flange positioned between the ends of the
tubular sleeve;
inserting an end of a first tubular member into an end of the tubular sleeve into abutment with
the internal flange;
inserting an end of a second tubular member into another end of the tubular sleeve into
abutment the internal flange;
threadably coupling the ends of the first and second tubular members;
radially expanding and plastically deforming only the portions of the first tubular member and
the second tubular member proximate the threads of the first and second tubular
members;
placing the tubular sleeve in circumferential tension;
placing the end of the first tubular member in circumferential compression; and
placing the end of the second tubular member in circumferential compression.
63. A method, comprising:
providing a tubular sleeve comprising an external flange positioned between the ends of the
tubular sleeve;
inserting an end of the tubular sleeve into an end of a first tubular member until the end of the
first tubular member abuts with the external flange;
inserting another end of the tubular sleeve into an end of the second tubular member until the
end of the second tubular member abuts the external flange;
threadably coupling the ends of the first and second tubular members;
radially expanding and plastically deforming only the portions of the first tubular member and
the second tubular member proximate the threads of the first and second tubular
members;
placing the tubular sleeve in circumferential compression;
placing the end of the first tubular member in circumferential tension; and

- placing the end of the second tubular member in circumferential tension.
64. An apparatus, comprising:
a tubular sleeve;
a first tubular member coupled to an end of the tubular sleeve; and
a second tubular member coupled to another end of the tubular sleeve and the first tubular member.
65. The apparatus of claim 64,
wherein the tubular sleeve is in circumferential tension;
wherein the end portion of the first tubular member is in circumferential compression; and
wherein the end portion of the second tubular member is in circumferential compression.
66. The apparatus of claim 64,
wherein the tubular sleeve is in circumferential compression;
wherein the end portion of the first tubular member is in circumferential tension; and
wherein the end portion of the second tubular member is in circumferential tension.
67. The apparatus of claim 64, wherein the tubular sleeve comprises an internal flange.
68. The apparatus of claim 67, wherein the end portion of the first tubular member is received within an end of the tubular sleeve; and wherein the end portion of the second tubular member is received within another end of the tubular sleeve.
69. The apparatus of claim 68, wherein the end portions of the first and second tubular members abut the internal flange of the tubular sleeve.
70. The apparatus of claim 67, wherein the end portion of the first tubular member is received within an end of the tubular sleeve.
71. The apparatus of claim 70, wherein the end portions of the first and second tubular members abut the internal flange of the tubular sleeve.
72. The apparatus of claim 67, wherein the end portion of the second tubular member is received within an end of the tubular sleeve.
73. The apparatus of claim 72, wherein the end portions of the first and second tubular members abut the internal flange of the tubular sleeve.
74. The apparatus of claim 67, wherein the internal flange of the tubular sleeve is positioned between the ends of the tubular sleeve.
75. The apparatus of claim 67, wherein the internal flange of the tubular sleeve is positioned at an end of the tubular sleeve.
76. The apparatus of claim 64, wherein the tubular sleeve comprises an external flange.
77. The apparatus of claim 76, wherein an end portion of the tubular sleeve is received within the first tubular member; and wherein another end portion of the tubular sleeve is received within the end portion of the second tubular member.

78. The apparatus of claim 77, wherein the end portions of the first and second tubular members abut the external flange of the tubular sleeve.
79. The apparatus of claim 76, wherein an end portion of the tubular sleeve is received within the end portion of the first tubular member.
80. The apparatus of claim 79, wherein the end portions of the first and second tubular members abut the external flange of the tubular sleeve.
81. The apparatus of claim 76, wherein an end portion of the tubular sleeve is received within the end portion of the second tubular member.
82. The apparatus of claim 81, wherein the end portions of the first and second tubular members abut the external flange of the tubular sleeve.
83. The apparatus of claim 76, wherein the external flange of the tubular sleeve is positioned between the ends of the tubular sleeve.
84. The apparatus of claim 76, wherein the external flange of the tubular sleeve is positioned at an end of the tubular sleeve.
85. The apparatus of claim 64, wherein the tubular sleeve further comprises one or more sealing members for sealing the interface between the tubular sleeve and at least one of the tubular members.
86. The apparatus of claim 64, further comprising:
a retaining ring positioned between the end of the first tubular member and the end of the tubular sleeve.
87. The apparatus of claim 86, further comprising:
another retaining ring positioned between the end of the second tubular member and the other end of the tubular sleeve.
88. The apparatus of claim 64, further comprising:
a retaining ring positioned between the end of the first tubular member and the other end of the tubular sleeve.
89. The apparatus of claim 86, wherein the retaining ring is resilient.
90. The apparatus of claim 87, wherein the retaining ring and the other retaining ring are resilient.
91. The apparatus of claim 88, wherein the retaining ring is resilient.
92. The apparatus of claim 64, wherein the end of the tubular sleeve is deformed onto the end of the first tubular member.
93. The apparatus of claim 92, wherein the other end of the tubular sleeve is deformed onto the end of the second tubular member.
94. The apparatus of claim 64, wherein the other end of the tubular sleeve is deformed onto the end of the second tubular member.
95. The apparatus of claim 64, further comprising:
a retaining ring coupled to the end of the first tubular member for retaining the tubular sleeve

- onto the end of the first tubular member.
96. The apparatus of claim 95, further comprising:
another retaining ring coupled to the end of the second tubular member for retaining the other end of the tubular sleeve onto the end of the second tubular member.
 97. The apparatus of claim 64, further comprising:
a retaining ring coupled to the end of the second tubular member for retaining the other end of the tubular sleeve onto the end of the second tubular member.
 98. The apparatus of claim 95, wherein the retaining ring is resilient.
 99. The apparatus of claim 96, wherein the retaining ring and the other retaining ring are resilient.
 100. The apparatus of claim 97, wherein the retaining ring is resilient.
 101. The apparatus of claim 64, further comprising:
a locking ring for coupling the end of the first tubular member to the end of the tubular sleeve.
 102. The apparatus of claim 101, further comprising:
another locking ring for coupling the end of the second tubular member to the other end of the tubular sleeve.
 103. The apparatus of claim 64, further comprising:
a locking ring for coupling the end of the second tubular member to the other end of the tubular sleeve.
 104. The apparatus of claim 64, further comprising:
a structure for receiving the first and second tubular members and the tubular sleeve;
wherein the tubular sleeve contacts the interior surface of the structure.
 105. The apparatus of claim 104, wherein the tubular sleeve further comprises:
a sealing member for fluidically sealing the interface between the tubular sleeve and the structure.
 106. The apparatus of claim 104, wherein the other structure comprises a wellbore.
 107. The apparatus of claim 104, wherein the other structure comprises a wellbore casing.
 108. The apparatus of claim 64, wherein the tubular sleeve further comprises a sealing element coupled to the exterior surface of the tubular sleeve.
 109. The apparatus of claim 64, wherein the tubular sleeve is metallic.
 110. The apparatus of claim 64, wherein the tubular sleeve is non-metallic.
 111. The apparatus of claim 64, wherein the tubular sleeve is plastic.
 112. The apparatus of claim 64, wherein the tubular sleeve is ceramic.
 113. The apparatus of claim 64, wherein the tubular sleeve is frangible.
 114. The apparatus of claim 64, wherein the tubular sleeve comprises one or more longitudinal slots.
 115. The apparatus of claim 64, wherein the tubular sleeve comprises one or more radial passages.

116. The apparatus of claim 64, wherein the first and second tubular members are amorously bonded.
117. The apparatus of claim 64, wherein the first and second tubular members are welded.
118. The apparatus of claim 64, wherein only the portions of the first and second tubular members proximate the tubular sleeve are plastically deformed.
119. The apparatus of claim 118, wherein a fluid tight seal is provided between the tubular sleeve and at least one of the first and second tubular members.
120. The apparatus of claim 64, wherein the first tubular member comprises internal threads; and wherein the second tubular member comprises external threads that engage the internal threads of the first tubular member.
121. The apparatus of claim 120, wherein only the portions of the first and second members proximate the threads of the first and second tubular members are plastically deformed.
122. The apparatus of claim 121, wherein a fluid tight seal is provided between the threads of the first and second tubular members.
123. The apparatus of claim 121, wherein a fluid tight seal is provided between the tubular sleeve and at least one of the first and second tubular members.
124. An apparatus, comprising:
a tubular sleeve comprising an internal flange positioned between the ends of the tubular sleeve;
a first tubular member received within an end of the tubular sleeve in abutment with the internal flange that comprises internal threads; and
a second tubular member received within another end of the tubular sleeve in abutment with the internal flange that comprises external threads that engage the internal threads of the first tubular member;
wherein the tubular sleeve is in circumferential tension;
wherein the end of first tubular member is in circumferential compression; and
wherein the end of the second tubular member is in circumferential compression.
125. An apparatus, comprising:
a tubular sleeve comprising an external flange positioned between the ends of the tubular sleeve;
a first tubular member that receives an end of the tubular sleeve and abuts the external flange that comprises internal threads; and
a second tubular member that receives another end of the tubular sleeve that abuts the external flange that comprises external threads that engage the internal threads of the first tubular member;
wherein the tubular sleeve is in circumferential compression;

- wherein the first tubular member is in circumferential tension; and
wherein the second tubular member is in circumferential tension.
126. An apparatus, comprising:
a tubular sleeve comprising an internal flange positioned between the ends of the tubular sleeve;
a first tubular member received within an end of the tubular sleeve in abutment with the internal flange that comprises internal threads; and
a second tubular member received within another end of the tubular sleeve in abutment with the internal flange that comprises external threads that engage the internal threads of the first tubular member;
wherein the tubular sleeve is in circumferential tension;
wherein the end of first tubular member is in circumferential compression;
wherein the end of the second tubular member is in circumferential compression;
wherein a fluid tight seal is provided between the tubular sleeve and at least one of the first and second tubular members; and
wherein a fluid tight seal is provided between the threads of the first and second tubular members.
127. An apparatus, comprising:
a tubular sleeve comprising an external flange positioned between the ends of the tubular sleeve;
a first tubular member that receives an end of the tubular sleeve and abuts the external flange that comprises internal threads; and
a second tubular member that receives another end of the tubular sleeve that abuts the external flange that comprises external threads that engage the internal threads of the first tubular member;
wherein the tubular sleeve is in circumferential compression;
wherein the first tubular member is in circumferential tension;
wherein the second tubular member is in circumferential tension;
wherein a fluid tight seal is provided between the tubular sleeve and at least one of the first and second tubular members; and
wherein a fluid tight seal is provided between the threads of the first and second tubular members.
128. A method of extracting geothermal energy from a subterranean source of geothermal energy, comprising:
drilling a borehole that traverses the subterranean source of geothermal energy;
positioning a first casing string within the borehole;

radially expanding and plastically deforming the first casing string within the borehole;
positioning a second casing string within the borehole that traverses the subterranean source of
geothermal energy;
overlapping a portion of the second casing string with a portion of the first casing string;
radially expanding and plastically deforming the second casing string within the borehole; and
extracting geothermal energy from the subterranean source of geothermal energy using the first
and second casing strings.

129. The method of claim 128, wherein the interior diameter of a passage defined by the first and second casing strings is constant.
130. The method of claim 128, wherein at least one of the first and second casing strings comprise:
a tubular sleeve;
a first tubular member coupled to an end of the tubular sleeve comprising internal threads at an end portion; and
a second tubular member coupled to another end of the tubular sleeve comprising external threads at an end portion that engage the internal threads of the end portion of the first tubular member.
131. A method of extracting geothermal energy from a subterranean source of geothermal energy, comprising:
drilling a borehole that traverses the subterranean source of geothermal energy;
positioning a first casing string within the borehole;
radially expanding and plastically deforming the first casing string within the borehole;
positioning a second casing string within the borehole that traverses the subterranean source of geothermal energy;
overlapping a portion of the second casing string with a portion of the first casing string;
radially expanding and plastically deforming the second casing string within the borehole; and
extracting geothermal energy from the subterranean source of geothermal energy using the first and second casing strings;
wherein the interior diameter of a passage defined by the first and second casing strings is constant; and
wherein at least one of the first and second casing strings comprise:
a tubular sleeve comprising an internal flange positioned between the ends of the tubular sleeve;
a first tubular member received within an end of the tubular sleeve in abutment with the internal flange that comprises internal threads; and
a second tubular member received within another end of the tubular sleeve in abutment with the internal flange that comprises external threads that engage

the internal threads of the first tubular member.

132. A method of extracting geothermal energy from a subterranean source of geothermal energy, comprising:
- drilling a borehole that traverses the subterranean source of geothermal energy;
 - positioning a first casing string within the borehole;
 - radially expanding and plastically deforming the first casing string within the borehole;
 - positioning a second casing string within the borehole that traverses the subterranean source of geothermal energy;
 - overlapping a portion of the second casing string with a portion of the first casing string;
 - radially expanding and plastically deforming the second casing string within the borehole; and
 - extracting geothermal energy from the subterranean source of geothermal energy using the first and second casing strings;
- wherein the interior diameter of a passage defined by the first and second casing strings is constant; and
- wherein at least one of the first and second casing strings comprise:
- a tubular sleeve comprising an external flange positioned between the ends of the tubular sleeve;
 - a first tubular member that receives an end of the tubular sleeve that abuts external flange that comprises internal threads; and
 - a second tubular member that receives another end of the tubular sleeve that abuts the external flange that comprises external threads that engage the internal threads of the first tubular member.
133. A method of extracting geothermal energy from a subterranean source of geothermal energy, comprising:
- drilling a borehole that traverses the subterranean source of geothermal energy;
 - positioning a first casing string within the borehole;
 - radially expanding and plastically deforming the first casing string within the borehole;
 - positioning a second casing string within the borehole that traverses the subterranean source of geothermal energy;
 - overlapping a portion of the second casing string with a portion of the first casing string;
 - radially expanding and plastically deforming the second casing string within the borehole; and
 - extracting geothermal energy from the subterranean source of geothermal energy using the first and second casing strings;
- wherein the interior diameter of a passage defined by the first and second casing strings is constant; and
- wherein at least one of the first and second casing strings comprise:

a tubular sleeve comprising an internal flange positioned between the ends of the tubular sleeve;

a first tubular member received within an end of the tubular sleeve in abutment with the internal flange that comprises internal threads; and

a second tubular member received within another end of the tubular sleeve in abutment with the internal flange that comprises external threads that engage the internal threads of the first tubular member;

wherein the tubular sleeve is in circumferential tension;

wherein the first tubular member is in circumferential compression;

wherein the second tubular member is in circumferential compression;

wherein a fluid tight seal is provided between the tubular sleeve and at least one of the first and second tubular members; and

wherein a fluid tight seal is provided between the threads of the first and second tubular members.

134. A method of extracting geothermal energy from a subterranean source of geothermal energy, comprising:
- drilling a borehole that traverses the subterranean source of geothermal energy;
- positioning a first casing string within the borehole;
- radially expanding and plastically deforming the first casing string within the borehole;
- positioning a second casing string within the borehole that traverses the subterranean source of geothermal energy;
- overlapping a portion of the second casing string with a portion of the first casing string;
- radially expanding and plastically deforming the second casing string within the borehole; and
- extracting geothermal energy from the subterranean source of geothermal energy using the first and second casing strings;
- wherein the interior diameter of a passage defined by the first and second casing strings is constant; and
- wherein at least one of the first and second casing strings comprise:
- a tubular sleeve comprising an external flange positioned between the ends of the tubular sleeve;
- a first tubular member that receives an end of the tubular sleeve that abuts external flange that comprises internal threads; and
- a second tubular member that receives another end of the tubular sleeve that abuts the external flange that comprises external threads that engage the internal threads of the first tubular member;
- wherein the tubular sleeve is in circumferential compression;

wherein the first tubular member is in circumferential tension;
wherein the second tubular member is in circumferential tension;
wherein a fluid tight seal is provided between the tubular sleeve and at least one of the
first and second tubular members; and
wherein a fluid tight seal is provided between the threads of the first and second
tubular members.

135. An apparatus for extracting geothermal energy from a subterranean source of geothermal energy, comprising:

a borehole that traverses the subterranean source of geothermal energy;
a first casing string positioned within the borehole; and
a second casing positioned within the borehole that overlaps with the first casing string that
traverses the subterranean source of geothermal energy;
wherein the first casing string and the second casing string are radially expanded and
plastically deformed within the borehole.

136. The apparatus of claim 135, wherein the interior diameter of a passage defined by the first and second casing strings is constant.

137. The apparatus of claim 135, wherein at least one of the first and second casing strings comprise:

a tubular sleeve;
a first tubular member coupled to an end of the tubular sleeve comprising internal threads at an
end portion; and
a second tubular member coupled to another end of the tubular sleeve comprising external
threads at an end portion that engage the internal threads of the end portion of the first
tubular member.

138. An apparatus for extracting geothermal energy from a subterranean source of geothermal energy, comprising:

a borehole that traverses the subterranean source of geothermal energy;
a first casing string positioned within the borehole;
a second casing string within the borehole that traverses the subterranean source of geothermal
energy that overlaps with the first casing string;
wherein the first and second casing strings are radially expanded and plastically deformed
within the borehole;
wherein the inside diameter of a passage defined by the first and second casing strings is
constant; and
wherein at least one of the first and second casing strings comprise:
a tubular sleeve comprising an internal flange positioned between the ends of the

tubular sleeve;

a first tubular member received within an end of the tubular sleeve in abutment with the internal flange that comprises internal threads; and

a second tubular member received within another end of the tubular sleeve in abutment with the internal flange that comprises external threads that engage the internal threads of the first tubular member.

139. An apparatus for extracting geothermal energy from a subterranean source of geothermal energy, comprising:

a borehole that traverses the subterranean source of geothermal energy;

a first casing string positioned within the borehole; and

a second casing string positioned within the borehole that traverses the subterranean source of geothermal energy that overlaps with the first casing string;

wherein the interior diameter of a passage defined by the first and second casing strings is constant; and

wherein at least one of the first and second casing strings comprise:

a tubular sleeve comprising an external flange positioned between the ends of the tubular sleeve;

a first tubular member that receives an end of the tubular sleeve that abuts external flange that comprises internal threads; and

a second tubular member that receives another end of the tubular sleeve that abuts the external flange that comprises external threads that engage the internal threads of the first tubular member.

140. An apparatus for extracting geothermal energy from a subterranean source of geothermal energy, comprising:

a borehole that traverses the subterranean source of geothermal energy;

a first casing string positioned within the borehole;

a second casing string within the borehole that traverses the subterranean source of geothermal energy that overlaps with the first casing string;

wherein the first and second casing strings are radially expanded and plastically deformed within the borehole;

wherein the inside diameter of a passage defined by the first and second casing strings is constant; and

wherein at least one of the first and second casing strings comprise:

a tubular sleeve comprising an internal flange positioned between the ends of the tubular sleeve;

a first tubular member received within an end of the tubular sleeve in abutment with

the internal flange that comprises internal threads;
a second tubular member received within another end of the tubular sleeve in
abutment with the internal flange that comprises external threads that engage
the internal threads of the first tubular member;
wherein the tubular sleeve is in circumferential tension;
wherein the first tubular member is in circumferential compression;
wherein the second tubular member is in circumferential compression;
wherein a fluid tight seal is provided between the tubular sleeve and at least one of the
first and second tubular members; and
wherein a fluid tight seal is provided between the threads of the first and second
tubular members.

141. An apparatus for extracting geothermal energy from a subterranean source of geothermal energy, comprising:

a borehole that traverses the subterranean source of geothermal energy;
a first casing string positioned within the borehole; and
a second casing string positioned within the borehole that traverses the subterranean source of
geothermal energy that overlaps with the first casing string;
wherein the interior diameter of a passage defined by the first and second casing strings is
constant; and
wherein at least one of the first and second casing strings comprise:
a tubular sleeve comprising an external flange positioned between the ends of the
tubular sleeve;
a first tubular member that receives an end of the tubular sleeve that abuts external
flange that comprises internal threads;
a second tubular member that receives another end of the tubular sleeve that abuts the
external flange that comprises external threads that engage the internal threads
of the first tubular member;
wherein the tubular sleeve is in circumferential compression;
wherein the first tubular member is in circumferential tension;
wherein the second tubular member is in circumferential tension;
wherein a fluid tight seal is provided between the tubular sleeve and at least one of the
first and second tubular members; and
wherein a fluid tight seal is provided between the threads of the first and second
tubular members.

142. A method, comprising:
coupling the ends of first and second tubular members;

- injecting a pressurized fluid through the first and second tubular members;
determining if any of the pressurized fluid leaks through the coupled ends of the first and second tubular members; and
if a predetermined amount of the pressurized fluid leaks through the coupled ends of the first and second tubular members, then coupling a tubular sleeve to the ends of the first and second tubular members and radially expanding and plastically deforming only the portions of the first and second tubular members proximate the tubular sleeve.
143. The method of claim 142, wherein radially expanding and plastically deforming only the portions of the first and second tubular members proximate the tubular sleeve comprises:
displacing an expansion cone within and relative to the first and second tubular members.
144. The method of claim 142, wherein radially expanding and plastically deforming only the portions of the first and second tubular members proximate the tubular sleeve comprises:
applying radial pressure to the interior surfaces of the first and second tubular member proximate the tubular sleeve using a rotating member.
145. The method of claim 1, further comprising:
transmitting energy through the first and second tubular members.
146. The method of claim 145, wherein the energy comprises electrical energy.
147. The method of claim 146, wherein the electrical energy comprises a communication signal.
148. The method of claim 145, wherein the energy comprises thermal energy.
149. The method of claim 145, wherein the energy comprises acoustic energy.
150. The method of claim 145, wherein the energy is transmitted through the first and second tubular members prior to radially expanding and plastically deforming the first and second tubular members.
151. The method of claim 145, wherein the energy is transmitted through the first and second tubular members after radially expanding and plastically deforming the first and second tubular members.
152. The method of claim 32, further comprising:
transmitting energy through the first and second tubular members.
153. The method of claim 152, wherein the energy comprises electrical energy.
154. The method of claim 153, wherein the electrical energy comprises a communication signal.
155. The method of claim 152, wherein the energy comprises thermal energy.
156. The method of claim 152, wherein the energy comprises acoustic energy.
157. The method of claim 152, wherein the energy is transmitted through the first and second tubular members prior to radially expanding and plastically deforming the first and second tubular members.
158. The method of claim 152, wherein the energy is transmitted through the first and second

tubular members after radially expanding and plastically deforming the first and second tubular members.

159. A system comprising:
a source of energy;
a borehole formed in the earth;
a first tubular member positioned within the borehole operably coupled to the source of energy;
a second tubular member positioned within the borehole coupled to the first tubular member;
and
a tubular sleeve positioned within the borehole coupled to the first and second tubular members;
wherein the first tubular member, second tubular member, and the tubular sleeve are plastically deformed into engagement with one another.
160. The system of claim 159, wherein the source of energy comprises a source of electrical energy.
161. The system of claim 159, wherein the source of energy comprises a source of thermal energy.
162. The system of claim 159, wherein the source of energy comprises a source of acoustic energy.
163. A method of operating a well for extracting hydrocarbons from a subterranean formation, comprising:
drilling a borehole into the earth that traverses the subterranean formation;
positioning a wellbore casing in the borehole;
transmitting energy through the wellbore casing; and
extracting hydrocarbons from the subterranean formation;
wherein the wellbore casing comprises:
a first tubular member;
a second tubular member coupled to the first tubular member; and
a tubular sleeve coupled to the first and second tubular member; and
wherein the first tubular member, the second tubular member, and the tubular sleeve are plastically deformed into engagement with one another.
164. The method of claim 163, wherein the energy comprises electrical energy.
165. The system of claim 163, wherein the energy comprises thermal energy.
166. The system of claim 163, wherein the energy comprises acoustic energy.
167. A method of extracting fluidic materials from first and second producing subterranean formations traversed by a borehole, comprising:
coupling an end of a first tubular member to an end of a tubular sleeve;
coupling an end of a second tubular member to another end of the first tubular sleeve;
coupling the ends of the first and second tubular members;

positioning the coupled first tubular member, second tubular member and first tubular sleeve within the borehole proximate the first producing subterranean formation;
radially expanding and plastically deforming the first tubular member, the second tubular member, and the first tubular sleeve within the borehole;
coupling an end of a third tubular member to an end of a second tubular sleeve;
coupling an end of a fourth tubular member to another end of the second tubular sleeve;
coupling the ends of the third and fourth tubular members;
positioning the coupled third tubular member, fourth tubular member and second tubular sleeve within the radially expanded and coupled first tubular member, second tubular member, and first tubular sleeve and the borehole proximate the second producing subterranean formation;
radially expanding and plastically deforming the third tubular member, the fourth tubular member, and the second tubular sleeve within the borehole;
extracting fluidic materials from the first producing subterranean formation through an annular passage defined between the radially expanded and coupled first tubular member, second tubular member, and first tubular sleeve and the radially expanded and coupled third tubular member, fourth tubular member, and second tubular sleeve; and
extracting fluidic materials from the second producing subterranean formation through a passage defined within the radially expanded and coupled third tubular member, fourth tubular member, and second tubular sleeve.

168. The method of claim 167, further comprising:
fluidically sealing an annular passage defined between the radially expanded and coupled first tubular member, second tubular member, and first tubular sleeve and the borehole; and
fluidically sealing an annular passage defined between the radially expanded and coupled third tubular member, fourth tubular member, and second tubular sleeve and the borehole.
169. A system for extracting fluidic materials from first and second producing subterranean formations traversed by a borehole, comprising:
means for coupling an end of a first tubular member to an end of a tubular sleeve;
means for coupling an end of a second tubular member to another end of the first tubular sleeve;
means for coupling the ends of the first and second tubular members;
means for positioning the coupled first tubular member, second tubular member and first tubular sleeve within the borehole proximate the first producing subterranean formation;
means for radially expanding and plastically deforming the first tubular member, the second tubular member, and the first tubular sleeve within the borehole;

means for coupling an end of a third tubular member to an end of a second tubular sleeve;
means for coupling an end of a fourth tubular member to another end of the second tubular sleeve;
means for coupling the ends of the third and fourth tubular members;
means for positioning the coupled third tubular member, fourth tubular member and second tubular sleeve within the radially expanded and coupled first tubular member, second tubular member, and first tubular sleeve and the borehole proximate the second producing subterranean formation;
means for radially expanding and plastically deforming the third tubular member, the fourth tubular member, and the second tubular sleeve within the borehole;
means for extracting fluidic materials from the first producing subterranean formation through an annular passage defined between the radially expanded and coupled first tubular member, second tubular member, and first tubular sleeve and the radially expanded and coupled third tubular member, fourth tubular member, and second tubular sleeve;
and
means for extracting fluidic materials from the second producing subterranean formation through a passage defined within the radially expanded and coupled third tubular member, fourth tubular member, and second tubular sleeve.

170. The system of claim 169, further comprising:

means for fluidically sealing an annular passage defined between the radially expanded and coupled first tubular member, second tubular member, and first tubular sleeve and the borehole; and
means for fluidically sealing an annular passage defined between the radially expanded and coupled third tubular member, fourth tubular member, and second tubular sleeve and the borehole.

AMENDED CLAIMS

[received by the International Bureau on 09 January 2004 (09.01.04);
original claim 64 cancelled; original claims 65, 67, 76, 85, 86, 88, 92, 94, 95, 97,
101, 103, 104, 106, 118 and 120 amended; remaining claims unchanged (18 pages)]

placing the end of the second tubular member in circumferential tension.

64. Cancelled

65. An apparatus, comprising:

a tubular sleeve;

a first tubular member coupled to an end of the tubular sleeve; and

a second tubular member coupled to another end of the tubular sleeve and the first tubular member;

wherein the tubular sleeve is in circumferential tension;

wherein the end portion of the first tubular member is in circumferential compression; and

wherein the end portion of the second tubular member is in circumferential compression.

66. An apparatus, comprising:

a tubular sleeve;

a first tubular member coupled to an end of the tubular sleeve; and

a second tubular member coupled to another end of the tubular sleeve and the first tubular member;

wherein the tubular sleeve is in circumferential compression;

wherein the end portion of the first tubular member is in circumferential tension; and

wherein the end portion of the second tubular member is in circumferential tension.

67. An apparatus, comprising:

a tubular sleeve;

a first tubular member coupled to an end of the tubular sleeve; and

a second tubular member coupled to another end of the tubular sleeve and the first tubular member;

wherein the tubular sleeve comprises an internal flange.

68. The apparatus of claim 67, wherein the end portion of the first tubular member is received within an end of the tubular sleeve; and wherein the end portion of the second tubular member is received within another end of the tubular sleeve.

69. The apparatus of claim 68, wherein the end portions of the first and second tubular members abut the internal flange of the tubular sleeve.

70. The apparatus of claim 67, wherein the end portion of the first tubular member is received within an end of the tubular sleeve.

71. The apparatus of claim 70, wherein the end portions of the first and second tubular members abut the internal flange of the tubular sleeve.

72. The apparatus of claim 67, wherein the end portion of the second tubular member is received within an end of the tubular sleeve.

73. The apparatus of claim 72, wherein the end portions of the first and second tubular members

abut the internal flange of the tubular sleeve .

74. The apparatus of claim 67, wherein the internal flange of the tubular sleeve is positioned between the ends of the tubular sleeve.
75. The apparatus of claim 67, wherein the internal flange of the tubular sleeve is positioned at an end of the tubular sleeve.
76. An apparatus, comprising:
a tubular sleeve;
a first tubular member coupled to an end of the tubular sleeve; and
a second tubular member coupled to another end of the tubular sleeve and the first tubular member;
wherein the tubular sleeve comprises an external flange.
77. The apparatus of claim 76, wherein an end portion of the tubular sleeve is received within the first tubular member, and wherein another end portion of the tubular sleeve is received within the end portion of the second tubular member.
78. The apparatus of claim 77, wherein the end portions of the first and second tubular members abut the external flange of the tubular sleeve.
79. The apparatus of claim 76, wherein an end portion of the tubular sleeve is received within the end portion of the first tubular member.
80. The apparatus of claim 79, wherein the end portions of the first and second tubular members abut the external flange of the tubular sleeve.
81. The apparatus of claim 76, wherein an end portion of the tubular sleeve is received within the end portion of the second tubular member.
82. The apparatus of claim 81, wherein the end portions of the first and second tubular members abut the external flange of the tubular sleeve.
83. The apparatus of claim 76, wherein the external flange of the tubular sleeve is positioned between the ends of the tubular sleeve.
84. The apparatus of claim 76, wherein the external flange of the tubular sleeve is positioned at an end of the tubular sleeve.
85. An apparatus, comprising:
a tubular sleeve;
a first tubular member coupled to an end of the tubular sleeve; and
a second tubular member coupled to another end of the tubular sleeve and the first tubular member;
wherein the tubular sleeve further comprises one or more sealing members for sealing the interface between the tubular sleeve and at least one of the tubular members.
86. An apparatus, comprising:

- a tubular sleeve;
a first tubular member coupled to an end of the tubular sleeve;
a second tubular member coupled to another end of the tubular sleeve and the first tubular member; and
a retaining ring positioned between the end of the first tubular member and the end of the tubular sleeve.
87. The apparatus of claim 86, further comprising:
another retaining ring positioned between the end of the second tubular member and the other end of the tubular sleeve.
88. An apparatus, comprising:
a tubular sleeve;
a first tubular member coupled to an end of the tubular sleeve;
a second tubular member coupled to another end of the tubular sleeve and the first tubular member; and
a retaining ring positioned between the end of the first tubular member and the other end of the tubular sleeve.
89. The apparatus of claim 86, wherein the retaining ring is resilient.
90. The apparatus of claim 87, wherein the retaining ring and the other retaining ring are resilient.
91. The apparatus of claim 88, wherein the retaining ring is resilient.
92. An apparatus, comprising:
a tubular sleeve;
a first tubular member coupled to an end of the tubular sleeve; and
a second tubular member coupled to another end of the tubular sleeve and the first tubular member;
wherein the end of the tubular sleeve is deformed onto the end of the first tubular member.
93. The apparatus of claim 92, wherein the other end of the tubular sleeve is deformed onto the end of the second tubular member.
94. An apparatus, comprising:
a tubular sleeve;
a first tubular member coupled to an end of the tubular sleeve; and
a second tubular member coupled to another end of the tubular sleeve and the first tubular member;
wherein the other end of the tubular sleeve is deformed onto the end of the second tubular member.
95. An apparatus, comprising:
a tubular sleeve;

- a first tubular member coupled to an end of the tubular sleeve;
a second tubular member coupled to another end of the tubular sleeve and the first tubular member; and
a retaining ring coupled to the end of the first tubular member for retaining the tubular sleeve onto the end of the first tubular member.
96. The apparatus of claim 95, further comprising:
another retaining ring coupled to the end of the second tubular member for retaining the other end of the tubular sleeve onto the end of the second tubular member.
97. An apparatus, comprising:
a tubular sleeve;
a first tubular member coupled to an end of the tubular sleeve;
a second tubular member coupled to another end of the tubular sleeve and the first tubular member; and
a retaining ring coupled to the end of the second tubular member for retaining the other end of the tubular sleeve onto the end of the second tubular member.
98. The apparatus of claim 95, wherein the retaining ring is resilient.
99. The apparatus of claim 96, wherein the retaining ring and the other retaining ring are resilient.
100. The apparatus of claim 97, wherein the retaining ring is resilient.
101. An apparatus, comprising:
a tubular sleeve;
a first tubular member coupled to an end of the tubular sleeve;
a second tubular member coupled to another end of the tubular sleeve and the first tubular member; and
a locking ring for coupling the end of the first tubular member to the end of the tubular sleeve.
102. The apparatus of claim 101, further comprising:
another locking ring for coupling the end of the second tubular member to the other end of the tubular sleeve.
103. An apparatus, comprising:
a tubular sleeve;
a first tubular member coupled to an end of the tubular sleeve;
a second tubular member coupled to another end of the tubular sleeve and the first tubular member; and
a locking ring for coupling the end of the second tubular member to the other end of the tubular sleeve.
104. An apparatus, comprising:
a tubular sleeve;

- a first tubular member coupled to an end of the tubular sleeve;
a second tubular member coupled to another end of the tubular sleeve and the first tubular member; and
a structure for receiving the first and second tubular members and the tubular sleeve;
wherein the tubular sleeve contacts the interior surface of the structure.
105. The apparatus of claim 104, wherein the tubular sleeve further comprises:
a sealing member for fluidically sealing the interface between the tubular sleeve and the structure.
106. The apparatus of claim 104, wherein the structure comprises a wellbore.
107. The apparatus of claim 104, wherein the structure comprises a wellbore casing.
108. An apparatus, comprising:
a tubular sleeve;
a first tubular member coupled to an end of the tubular sleeve; and
a second tubular member coupled to another end of the tubular sleeve and the first tubular member;
wherein the tubular sleeve further comprises a sealing element coupled to the exterior surface of the tubular sleeve.
109. An apparatus, comprising:
a tubular sleeve;
a first tubular member coupled to an end of the tubular sleeve; and
a second tubular member coupled to another end of the tubular sleeve and the first tubular member;
wherein the tubular sleeve is metallic.
110. An apparatus, comprising:
a tubular sleeve;
a first tubular member coupled to an end of the tubular sleeve; and
a second tubular member coupled to another end of the tubular sleeve and the first tubular member;
wherein the tubular sleeve is non-metallic.
111. An apparatus, comprising:
a tubular sleeve;
a first tubular member coupled to an end of the tubular sleeve; and
a second tubular member coupled to another end of the tubular sleeve and the first tubular member;
wherein the tubular sleeve is plastic.
112. An apparatus, comprising:

- a tubular sleeve;
a first tubular member coupled to an end of the tubular sleeve; and
a second tubular member coupled to another end of the tubular sleeve and the first tubular member;
wherein the tubular sleeve is ceramic.
113. An apparatus, comprising:
a tubular sleeve;
a first tubular member coupled to an end of the tubular sleeve; and
a second tubular member coupled to another end of the tubular sleeve and the first tubular member;
wherein the tubular sleeve is frangible.
114. An apparatus, comprising:
a tubular sleeve;
a first tubular member coupled to an end of the tubular sleeve; and
a second tubular member coupled to another end of the tubular sleeve and the first tubular member;
wherein the tubular sleeve comprises one or more longitudinal slots.
115. An apparatus, comprising:
a tubular sleeve;
a first tubular member coupled to an end of the tubular sleeve; and
a second tubular member coupled to another end of the tubular sleeve and the first tubular member;
wherein the tubular sleeve comprises one or more radial passages.
116. An apparatus, comprising:
a tubular sleeve;
a first tubular member coupled to an end of the tubular sleeve; and
a second tubular member coupled to another end of the tubular sleeve and the first tubular member;
wherein the first and second tubular members are amorphaously bonded.
117. An apparatus, comprising:
a tubular sleeve;
a first tubular member coupled to an end of the tubular sleeve; and
a second tubular member coupled to another end of the tubular sleeve and the first tubular member;
wherein the first and second tubular members are welded.
118. An apparatus, comprising:

a tubular sleeve;
a first tubular member coupled to an end of the tubular sleeve; and
a second tubular member coupled to another end of the tubular sleeve and the first tubular member;

wherein only the portions of the first and second tubular members proximate the tubular sleeve are plastically deformed.

119. The apparatus of claim 118, wherein a fluid tight seal is provided between the tubular sleeve and at least one of the first and second tubular members.

120. An apparatus, comprising:

a tubular sleeve;
a first tubular member coupled to an end of the tubular sleeve; and
a second tubular member coupled to another end of the tubular sleeve and the first tubular member;

wherein the first tubular member comprises internal threads; and wherein the second tubular member comprises external threads that engage the internal threads of the first tubular member.

121. The apparatus of claim 120, wherein only the portions of the first and second members proximate the threads of the first and second tubular members are plastically deformed.

122. The apparatus of claim 121, wherein a fluid tight seal is provided between the threads of the first and second tubular members.

123. The apparatus of claim 121, wherein a fluid tight seal is provided between the tubular sleeve and at least one of the first and second tubular members.

124. An apparatus, comprising:

a tubular sleeve comprising an internal flange positioned between the ends of the tubular sleeve;
a first tubular member received within an end of the tubular sleeve in abutment with the internal flange that comprises internal threads; and
a second tubular member received within another end of the tubular sleeve in abutment with the internal flange that comprises external threads that engage the internal threads of the first tubular member;

wherein the tubular sleeve is in circumferential tension;

wherein the end of first tubular member is in circumferential compression; and

wherein the end of the second tubular member is in circumferential compression.

125. An apparatus, comprising:

a tubular sleeve comprising an external flange positioned between the ends of the tubular sleeve;

a first tubular member that receives an end of the tubular sleeve and abuts the external flange

that comprises internal threads and
 a second tubular member that receives another end of the tubular sleeve that abuts the external
 flange that comprises external threads that engage the internal threads of the first
 tubular member;

wherein the tubular sleeve is in circumferential compression;

wherein the first tubular member is in circumferential tension; and

wherein the second tubular member is in circumferential tension.

126. An apparatus, comprising:

a tubular sleeve comprising an internal flange positioned between the ends of the tubular
 sleeve;

a first tubular member received within an end of the tubular sleeve in abutment with the
 internal flange that comprises internal threads; and

a second tubular member received within another end of the tubular sleeve in abutment with
 the internal flange that comprises external threads that engage the internal threads of
 the first tubular member;

wherein the tubular sleeve is in circumferential tension;

wherein the end of first tubular member is in circumferential compression;

wherein the end of the second tubular member is in circumferential compression;

wherein a fluid tight seal is provided between the tubular sleeve and at least one of the first and
 second tubular members; and

wherein a fluid tight seal is provided between the threads of the first and second tubular
 members.

127. An apparatus, comprising:

a tubular sleeve comprising an external flange positioned between the ends of the tubular
 sleeve;

a first tubular member that receives an end of the tubular sleeve and abuts the external flange
 that comprises internal threads; and

a second tubular member that receives another end of the tubular sleeve that abuts the external
 flange that comprises external threads that engage the internal threads of the first
 tubular member;

wherein the tubular sleeve is in circumferential compression;

wherein the first tubular member is in circumferential tension;

wherein the second tubular member is in circumferential tension;

wherein a fluid tight seal is provided between the tubular sleeve and at least one of the first and
 second tubular members; and

wherein a fluid tight seal is provided between the threads of the first and second tubular

members.

128. A method of extracting geothermal energy from a subterranean source of geothermal energy, comprising:

drilling a borehole that traverses the subterranean source of geothermal energy;
positioning a first casing string within the borehole;
radially expanding and plastically deforming the first casing string within the borehole;
positioning a second casing string within the borehole that traverses the subterranean source of geothermal energy;

overlapping a portion of the second casing string with a portion of the first casing string;
radially expanding and plastically deforming the second casing string within the borehole; and
extracting geothermal energy from the subterranean source of geothermal energy using the first and second casing strings.

129. The method of claim 128, wherein the interior diameter of a passage defined by the first and second casing strings is constant.

130. The method of claim 128, wherein at least one of the first and second casing strings comprise:

a tubular sleeve;

a first tubular member coupled to an end of the tubular sleeve comprising internal threads at an end portion; and

a second tubular member coupled to another end of the tubular sleeve comprising external threads at an end portion that engage the internal threads of the end portion of the first tubular member.

131. A method of extracting geothermal energy from a subterranean source of geothermal energy, comprising:

drilling a borehole that traverses the subterranean source of geothermal energy;
positioning a first casing string within the borehole;
radially expanding and plastically deforming the first casing string within the borehole;
positioning a second casing string within the borehole that traverses the subterranean source of geothermal energy;

overlapping a portion of the second casing string with a portion of the first casing string;
radially expanding and plastically deforming the second casing string within the borehole; and
extracting geothermal energy from the subterranean source of geothermal energy using the first and second casing strings;

wherein the interior diameter of a passage defined by the first and second casing strings is constant; and

wherein at least one of the first and second casing strings comprise:

a tubular sleeve comprising an internal flange positioned between the ends of the

tubular sleeve;

a first tubular member received within an end of the tubular sleeve in abutment with the internal flange that comprises internal threads; and

a second tubular member received within another end of the tubular sleeve in abutment with the internal flange that comprises external threads that engage the internal threads of the first tubular member.

132. A method of extracting geothermal energy from a subterranean source of geothermal energy, comprising:
- drilling a borehole that traverses the subterranean source of geothermal energy;
 - positioning a first casing string within the borehole;
 - radially expanding and plastically deforming the first casing string within the borehole;
 - positioning a second casing string within the borehole that traverses the subterranean source of geothermal energy;
 - overlapping a portion of the second casing string with a portion of the first casing string;
 - radially expanding and plastically deforming the second casing string within the borehole; and
 - extracting geothermal energy from the subterranean source of geothermal energy using the first and second casing strings;
- wherein the interior diameter of a passage defined by the first and second casing strings is constant; and
- wherein at least one of the first and second casing strings comprise:
- a tubular sleeve comprising an external flange positioned between the ends of the tubular sleeve;
 - a first tubular member that receives an end of the tubular sleeve that abuts external flange that comprises internal threads; and
 - a second tubular member that receives another end of the tubular sleeve that abuts the external flange that comprises external threads that engage the internal threads of the first tubular member.
133. A method of extracting geothermal energy from a subterranean source of geothermal energy, comprising:
- drilling a borehole that traverses the subterranean source of geothermal energy;
 - positioning a first casing string within the borehole;
 - radially expanding and plastically deforming the first casing string within the borehole;
 - positioning a second casing string within the borehole that traverses the subterranean source of geothermal energy;
 - overlapping a portion of the second casing string with a portion of the first casing string;
 - radially expanding and plastically deforming the second casing string within the borehole; and

extracting geothermal energy from the subterranean source of geothermal energy using the first and second casing strings;

wherein the interior diameter of a passage defined by the first and second casing strings is constant; and

wherein at least one of the first and second casing strings comprise:

a tubular sleeve comprising an internal flange positioned between the ends of the tubular sleeve;

a first tubular member received within an end of the tubular sleeve in abutment with the internal flange that comprises internal threads; and

a second tubular member received within another end of the tubular sleeve in abutment with the internal flange that comprises external threads that engage the internal threads of the first tubular member;

wherein the tubular sleeve is in circumferential tension;

wherein the first tubular member is in circumferential compression;

wherein the second tubular member is in circumferential compression;

wherein a fluid tight seal is provided between the tubular sleeve and at least one of the first and second tubular members; and

wherein a fluid tight seal is provided between the threads of the first and second tubular members.

134. A method of extracting geothermal energy from a subterranean source of geothermal energy, comprising:
- drilling a borehole that traverses the subterranean source of geothermal energy;
- positioning a first casing string within the borehole;
- radially expanding and plastically deforming the first casing string within the borehole;
- positioning a second casing string within the borehole that traverses the subterranean source of geothermal energy;
- overlapping a portion of the second casing string with a portion of the first casing string;
- radially expanding and plastically deforming the second casing string within the borehole; and
- extracting geothermal energy from the subterranean source of geothermal energy using the first and second casing strings;
- wherein the interior diameter of a passage defined by the first and second casing strings is constant; and
- wherein at least one of the first and second casing strings comprise:
- a tubular sleeve comprising an external flange positioned between the ends of the tubular sleeve;
- a first tubular member that receives an end of the tubular sleeve that abuts external

flange that comprises internal threads; and
 a second tubular member that receives another end of the tubular sleeve that abuts the
 external flange that comprises external threads that engage the internal threads
 of the first tubular member,
 wherein the tubular sleeve is in circumferential compression;
 wherein the first tubular member is in circumferential tension;
 wherein the second tubular member is in circumferential tension;
 wherein a fluid tight seal is provided between the tubular sleeve and at least one of the
 first and second tubular members, and
 wherein a fluid tight seal is provided between the threads of the first and second
 tubular members.

135. An apparatus for extracting geothermal energy from a subterranean source of geothermal energy, comprising:

a borehole that traverses the subterranean source of geothermal energy;
 a first casing string positioned within the borehole; and
 a second casing positioned within the borehole that overlaps with the first casing string that
 traverses the subterranean source of geothermal energy;
 wherein the first casing string and the second casing string are radially expanded and
 plastically deformed within the borehole.

136. The apparatus of claim 135, wherein the interior diameter of a passage defined by the first and second casing strings is constant.

137. The apparatus of claim 135, wherein at least one of the first and second casing strings comprise:

a tubular sleeve;
 a first tubular member coupled to an end of the tubular sleeve comprising internal threads at an
 end portion; and
 a second tubular member coupled to another end of the tubular sleeve comprising external
 threads at an end portion that engage the internal threads of the end portion of the first
 tubular member.

138. An apparatus for extracting geothermal energy from a subterranean source of geothermal energy, comprising:

a borehole that traverses the subterranean source of geothermal energy;
 a first casing string positioned within the borehole;
 a second casing string within the borehole that traverses the subterranean source of geothermal
 energy that overlaps with the first casing string;
 wherein the first and second casing strings are radially expanded and plastically deformed

within the borehole;
 wherein the inside diameter of a passage defined by the first and second casing strings is constant; and
 wherein at least one of the first and second casing strings comprise:
 a tubular sleeve comprising an internal flange positioned between the ends of the tubular sleeve;
 a first tubular member received within an end of the tubular sleeve in abutment with the internal flange that comprises internal threads; and
 a second tubular member received within another end of the tubular sleeve in abutment with the internal flange that comprises external threads that engage the internal threads of the first tubular member.

139. An apparatus for extracting geothermal energy from a subterranean source of geothermal energy, comprising:

a borehole that traverses the subterranean source of geothermal energy;
 a first casing string positioned within the borehole; and
 a second casing string positioned within the borehole that traverses the subterranean source of geothermal energy that overlaps with the first casing string;
 wherein the interior diameter of a passage defined by the first and second casing strings is constant; and
 wherein at least one of the first and second casing strings comprise:
 a tubular sleeve comprising an external flange positioned between the ends of the tubular sleeve;
 a first tubular member that receives an end of the tubular sleeve that abuts external flange that comprises internal threads; and
 a second tubular member that receives another end of the tubular sleeve that abuts the external flange that comprises external threads that engage the internal threads of the first tubular member.

140. An apparatus for extracting geothermal energy from a subterranean source of geothermal energy, comprising:

a borehole that traverses the subterranean source of geothermal energy;
 a first casing string positioned within the borehole;
 a second casing string within the borehole that traverses the subterranean source of geothermal energy that overlaps with the first casing string;
 wherein the first and second casing strings are radially expanded and plastically deformed within the borehole;
 wherein the inside diameter of a passage defined by the first and second casing strings is

constant; and

wherein at least one of the first and second casing strings comprise:

a tubular sleeve comprising an internal flange positioned between the ends of the tubular sleeve;

a first tubular member received within an end of the tubular sleeve in abutment with the internal flange that comprises internal threads;

a second tubular member received within another end of the tubular sleeve in abutment with the internal flange that comprises external threads that engage the internal threads of the first tubular member;

wherein the tubular sleeve is in circumferential tension;

wherein the first tubular member is in circumferential compression;

wherein the second tubular member is in circumferential compression;

wherein a fluid tight seal is provided between the tubular sleeve and at least one of the first and second tubular members; and

wherein a fluid tight seal is provided between the threads of the first and second tubular members.

141. An apparatus for extracting geothermal energy from a subterranean source of geothermal energy, comprising:

a borehole that traverses the subterranean source of geothermal energy;

a first casing string positioned within the borehole; and

a second casing string positioned within the borehole that traverses the subterranean source of geothermal energy that overlaps with the first casing string;

wherein the interior diameter of a passage defined by the first and second casing strings is constant; and

wherein at least one of the first and second casing strings comprise:

a tubular sleeve comprising an external flange positioned between the ends of the tubular sleeve;

a first tubular member that receives an end of the tubular sleeve that abuts external flange that comprises internal threads;

a second tubular member that receives another end of the tubular sleeve that abuts the external flange that comprises external threads that engage the internal threads of the first tubular member;

wherein the tubular sleeve is in circumferential compression;

wherein the first tubular member is in circumferential tension;

wherein the second tubular member is in circumferential tension;

wherein a fluid tight seal is provided between the tubular sleeve and at least one of the

first and second tubular members; and
wherein a fluid tight seal is provided between the threads of the first and second
tubular members.

142. A method, comprising:
coupling the ends of first and second tubular members;
injecting a pressurized fluid through the first and second tubular members;
determining if any of the pressurized fluid leaks through the coupled ends of the first and
second tubular members; and
if a predetermined amount of the pressurized fluid leaks through the coupled ends of the first
and second tubular members, then coupling a tubular sleeve to the ends of the first and
second tubular members and radially expanding and plastically deforming only the
portions of the first and second tubular members proximate the tubular sleeve.
143. The method of claim 142, wherein radially expanding and plastically deforming only the
portions of the first and second tubular members proximate the tubular sleeve comprises:
displacing an expansion cone within and relative to the first and second tubular members.
144. The method of claim 142, wherein radially expanding and plastically deforming only the
portions of the first and second tubular members proximate the tubular sleeve comprises:
applying radial pressure to the interior surfaces of the first and second tubular member
proximate the tubular sleeve using a rotating member.
145. The method of claim 1, further comprising:
transmitting energy through the first and second tubular members.
146. The method of claim 145, wherein the energy comprises electrical energy.
147. The method of claim 146, wherein the electrical energy comprises a communication signal.
148. The method of claim 145, wherein the energy comprises thermal energy.
149. The method of claim 145, wherein the energy comprises acoustic energy.
150. The method of claim 145, wherein the energy is transmitted through the first and second
tubular members prior to radially expanding and plastically deforming the first and second tubular
members.
151. The method of claim 145, wherein the energy is transmitted through the first and second
tubular members after radially expanding and plastically deforming the first and second tubular
members.
152. The method of claim 32, further comprising:
transmitting energy through the first and second tubular members.
153. The method of claim 152, wherein the energy comprises electrical energy.
154. The method of claim 153, wherein the electrical energy comprises a communication signal.
155. The method of claim 152, wherein the energy comprises thermal energy.

156. The method of claim 152, wherein the energy comprises acoustic energy.
157. The method of claim 152, wherein the energy is transmitted through the first and second tubular members prior to radially expanding and plastically deforming the first and second tubular members.
158. The method of claim 152, wherein the energy is transmitted through the first and second tubular members after radially expanding and plastically deforming the first and second tubular members.
159. A system comprising:
a source of energy;
a borehole formed in the earth;
a first tubular member positioned within the borehole operably coupled to the source of energy;
a second tubular member positioned within the borehole coupled to the first tubular member;
and
a tubular sleeve positioned within the borehole coupled to the first and second tubular members;
wherein the first tubular member, second tubular member, and the tubular sleeve are plastically deformed into engagement with one another.
160. The system of claim 159, wherein the source of energy comprises a source of electrical energy.
161. The system of claim 159, wherein the source of energy comprises a source of thermal energy.
162. The system of claim 159, wherein the source of energy comprises a source of acoustic energy.
163. A method of operating a well for extracting hydrocarbons from a subterranean formation, comprising:
drilling a borehole into the earth that traverses the subterranean formation;
positioning a wellbore casing in the borehole;
transmitting energy through the wellbore casing; and
extracting hydrocarbons from the subterranean formation;
wherein the wellbore casing comprises:
a first tubular member;
a second tubular member coupled to the first tubular member; and
a tubular sleeve coupled to the first and second tubular member; and
wherein the first tubular member, the second tubular member, and the tubular sleeve are plastically deformed into engagement with one another.
164. The method of claim 163, wherein the energy comprises electrical energy.
165. The system of claim 163, wherein the energy comprises thermal energy.
166. The system of claim 163, wherein the energy comprises acoustic energy.

167. A method of extracting fluidic materials from first and second producing subterranean formations traversed by a borehole, comprising:
- coupling an end of a first tubular member to an end of a tubular sleeve;
 - coupling an end of a second tubular member to another end of the first tubular sleeve;
 - coupling the ends of the first and second tubular members;
 - positioning the coupled first tubular member, second tubular member and first tubular sleeve within the borehole proximate the first producing subterranean formation;
 - radially expanding and plastically deforming the first tubular member, the second tubular member, and the first tubular sleeve within the borehole;
 - coupling an end of a third tubular member to an end of a second tubular sleeve;
 - coupling an end of a fourth tubular member to another end of the second tubular sleeve;
 - coupling the ends of the third and fourth tubular members;
 - positioning the coupled third tubular member, fourth tubular member and second tubular sleeve within the radially expanded and coupled first tubular member, second tubular member, and first tubular sleeve and the borehole proximate the second producing subterranean formation;
 - radially expanding and plastically deforming the third tubular member, the fourth tubular member, and the second tubular sleeve within the borehole;
 - extracting fluidic materials from the first producing subterranean formation through an annular passage defined between the radially expanded and coupled first tubular member, second tubular member, and first tubular sleeve and the radially expanded and coupled third tubular member, fourth tubular member, and second tubular sleeve; and
 - extracting fluidic materials from the second producing subterranean formation through a passage defined within the radially expanded and coupled third tubular member, fourth tubular member, and second tubular sleeve.
168. The method of claim 167, further comprising:
- fluidically sealing an annular passage defined between the radially expanded and coupled first tubular member, second tubular member, and first tubular sleeve and the borehole; and
 - fluidically sealing an annular passage defined between the radially expanded and coupled third tubular member, fourth tubular member, and second tubular sleeve and the borehole.
169. A system for extracting fluidic materials from first and second producing subterranean formations traversed by a borehole, comprising:
- means for coupling an end of a first tubular member to an end of a tubular sleeve;
 - means for coupling an end of a second tubular member to another end of the first tubular sleeve;
 - means for coupling the ends of the first and second tubular members;

means for positioning the coupled first tubular member, second tubular member and first tubular sleeve within the borehole proximate the first producing subterranean formation;

means for radially expanding and plastically deforming the first tubular member, the second tubular member, and the first tubular sleeve within the borehole;

means for coupling an end of a third tubular member to an end of a second tubular sleeve;

means for coupling an end of a fourth tubular member to another end of the second tubular sleeve;

means for coupling the ends of the third and fourth tubular members;

means for positioning the coupled third tubular member, fourth tubular member and second tubular sleeve within the radially expanded and coupled first tubular member, second tubular member, and first tubular sleeve and the borehole proximate the second producing subterranean formation;

means for radially expanding and plastically deforming the third tubular member, the fourth tubular member, and the second tubular sleeve within the borehole;

means for extracting fluidic materials from the first producing subterranean formation through an annular passage defined between the radially expanded and coupled first tubular member, second tubular member, and first tubular sleeve and the radially expanded and coupled third tubular member, fourth tubular member, and second tubular sleeve;

and

means for extracting fluidic materials from the second producing subterranean formation through a passage defined within the radially expanded and coupled third tubular member, fourth tubular member, and second tubular sleeve.

170. The system of claim 169, further comprising:

means for fluidically sealing an annular passage defined between the radially expanded and coupled first tubular member, second tubular member, and first tubular sleeve and the borehole; and

means for fluidically sealing an annular passage defined between the radially expanded and coupled third tubular member, fourth tubular member, and second tubular sleeve and the borehole.

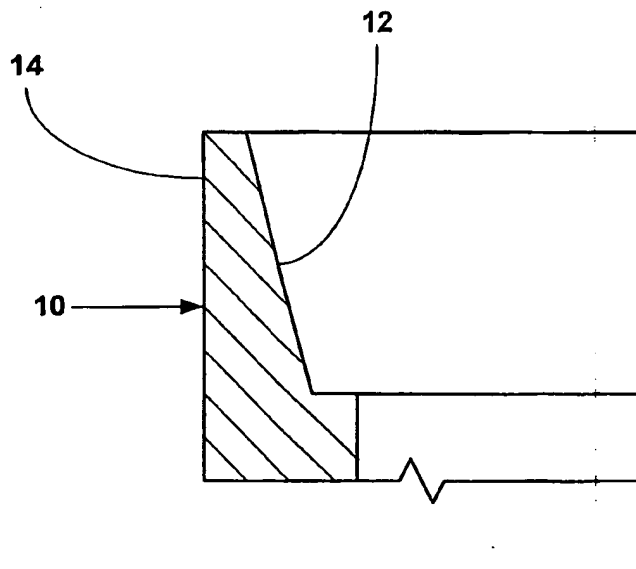

Fig. 1a

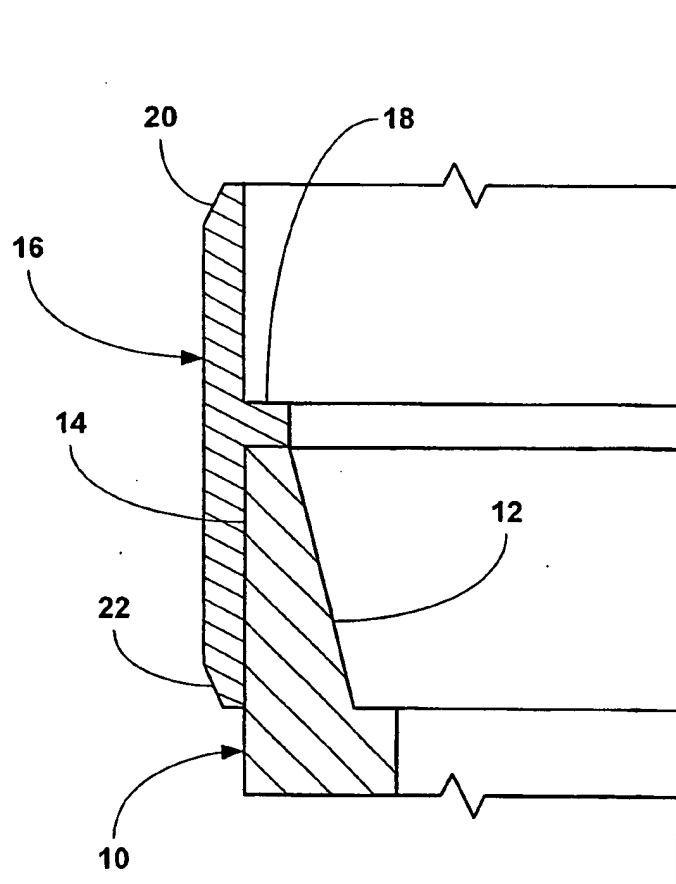

Fig. 1b

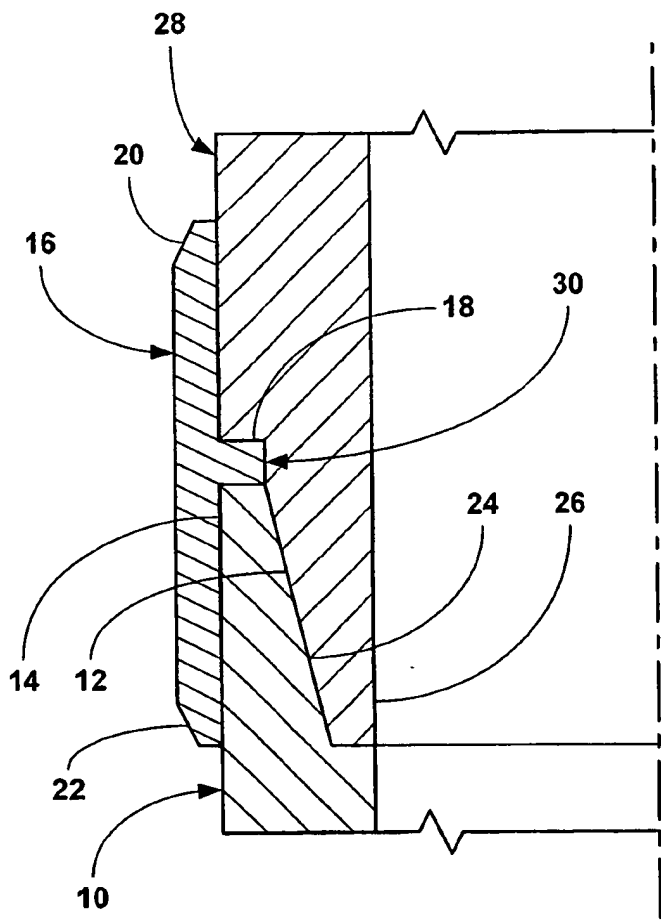

Fig. 1c

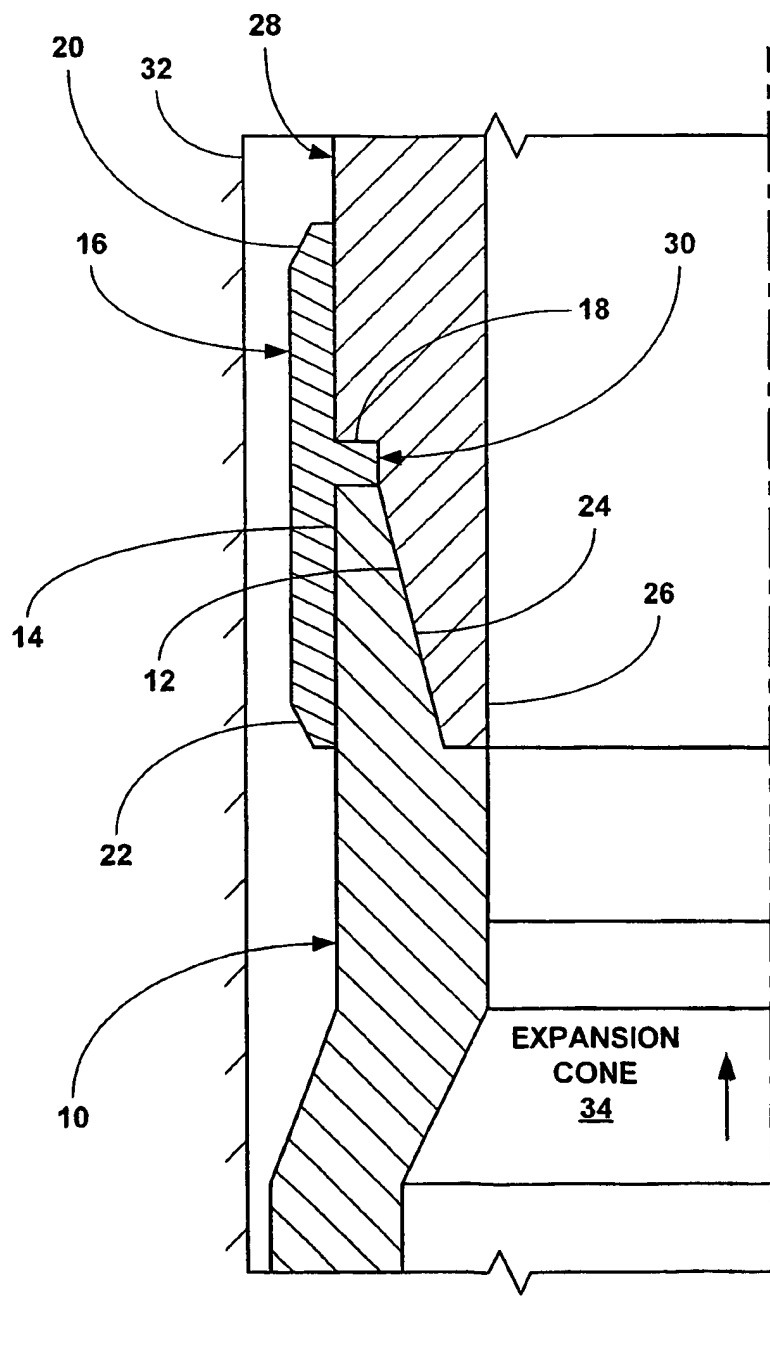

Fig. 1d

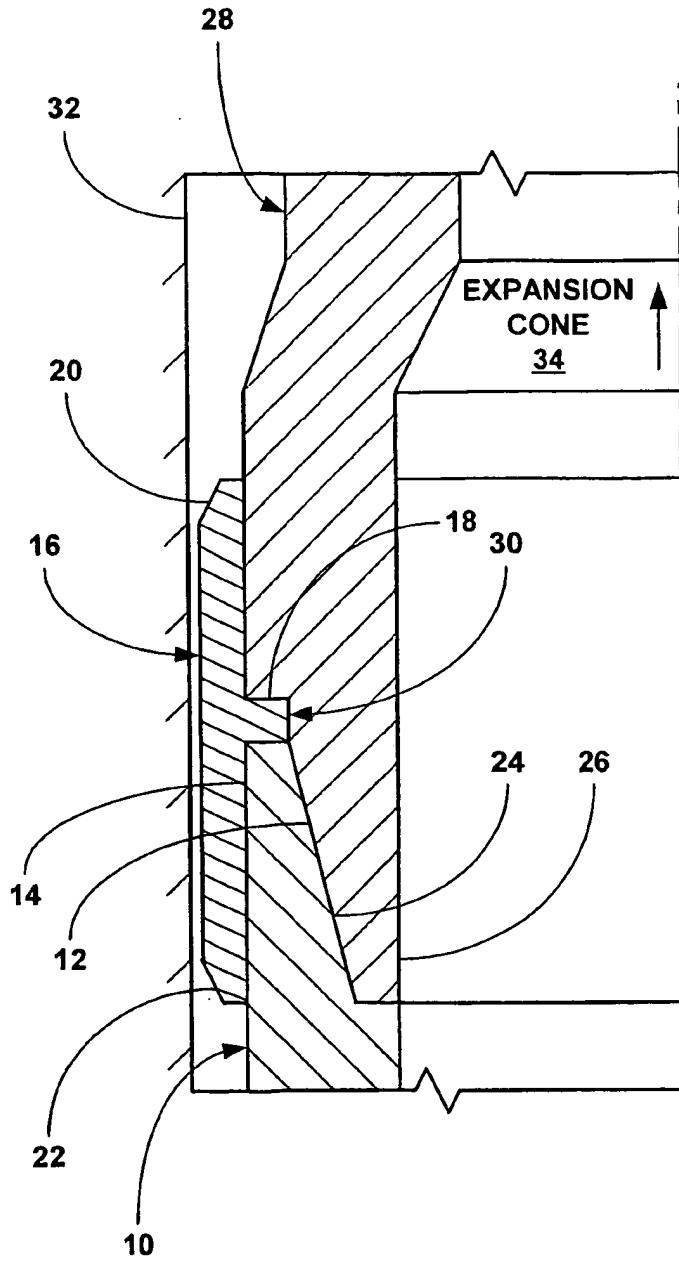

Fig. 1e

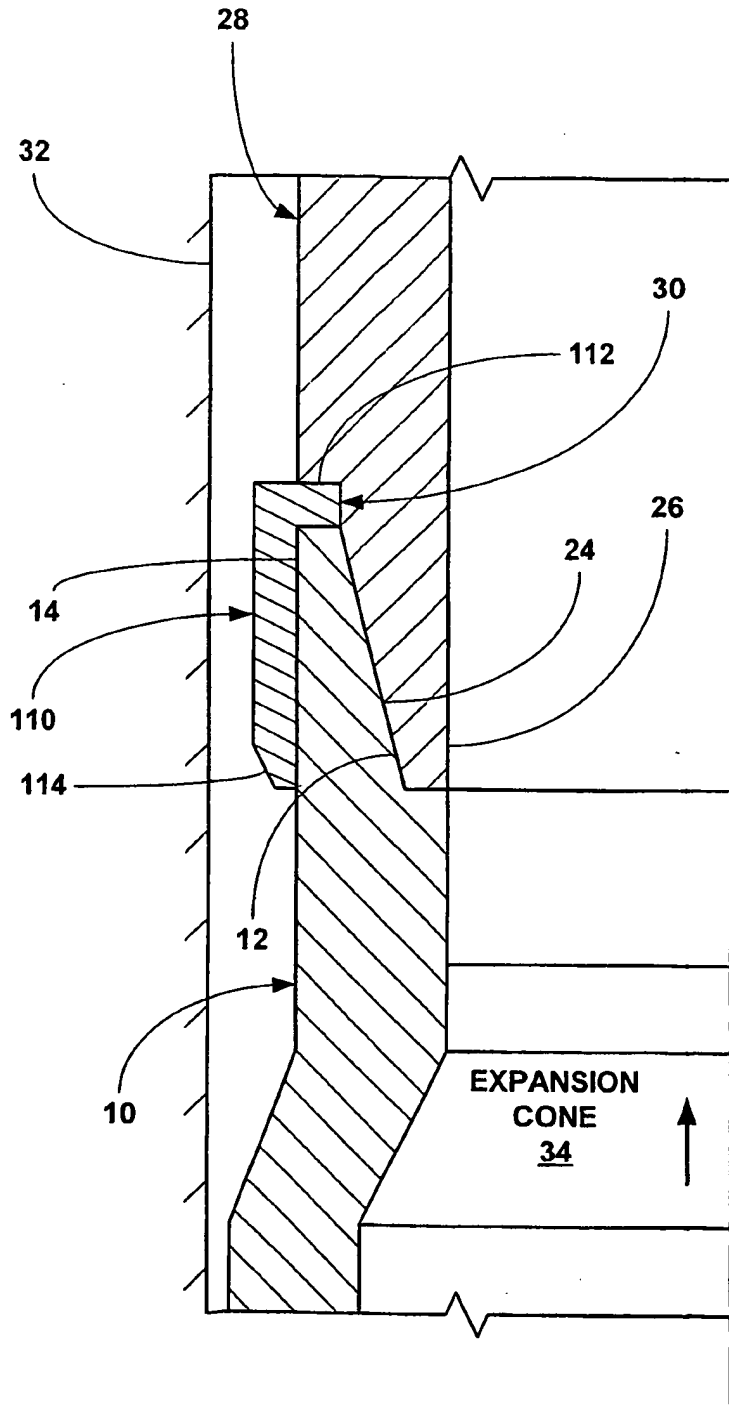

Fig. 2a

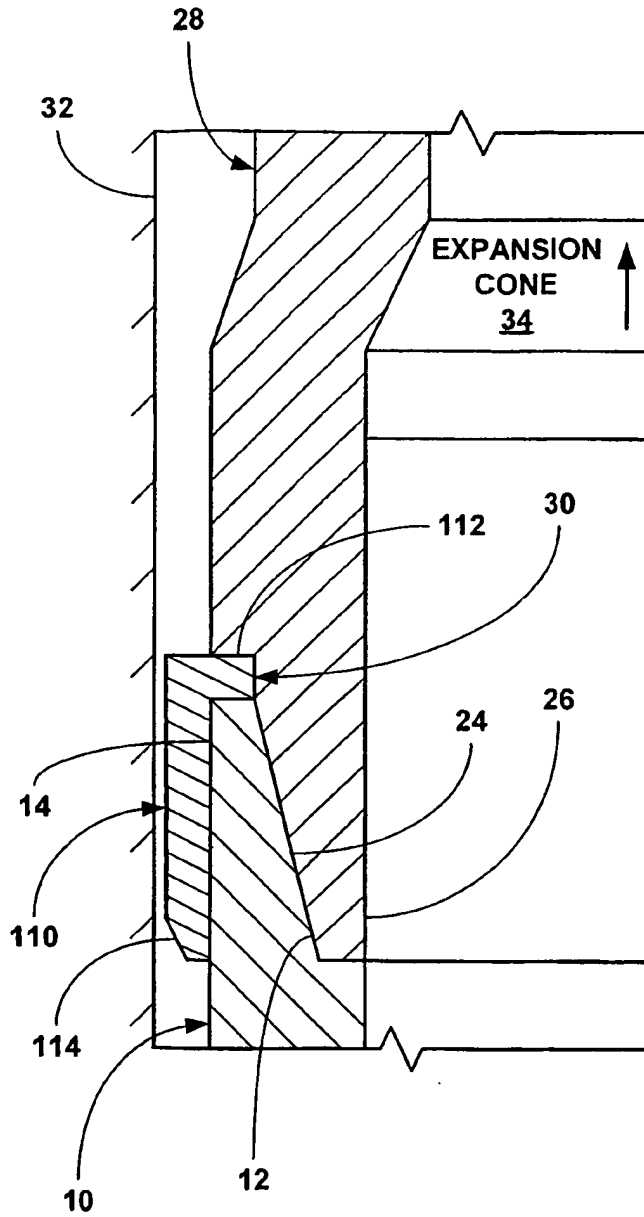

Fig. 2b

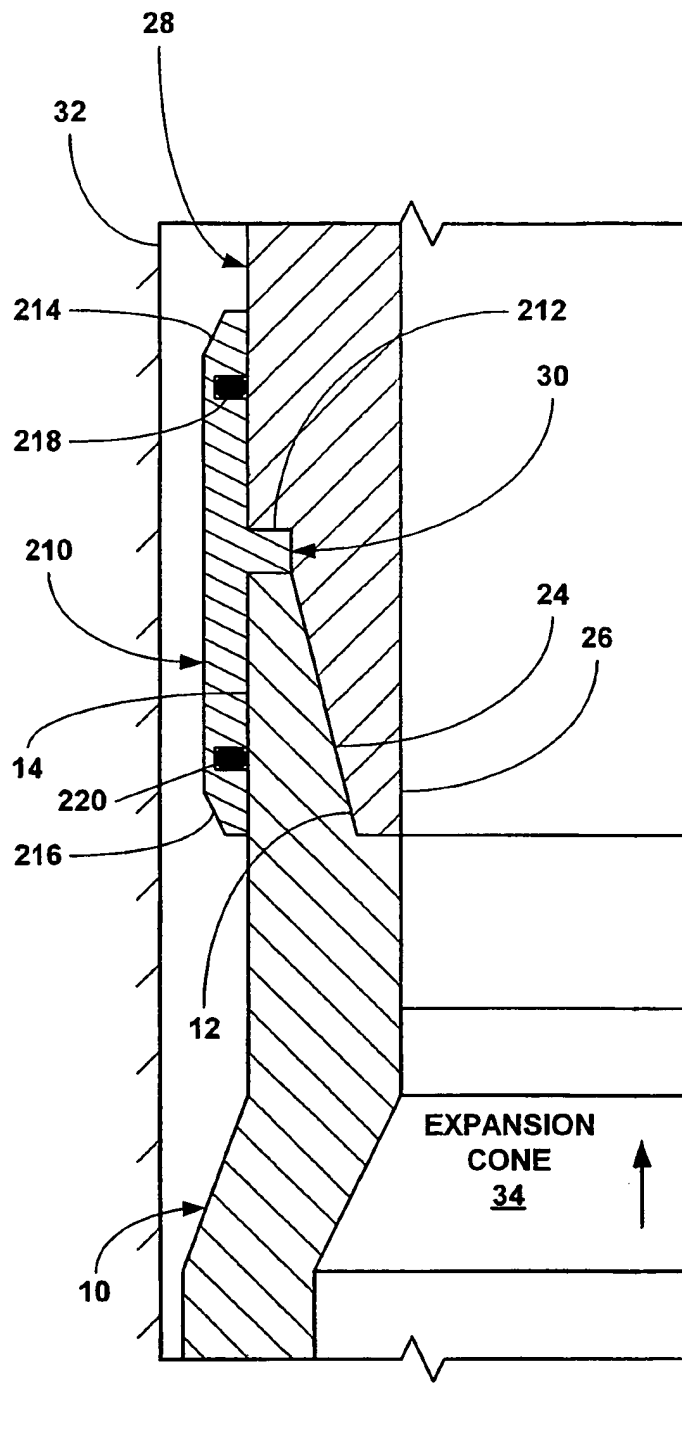

Fig. 3a

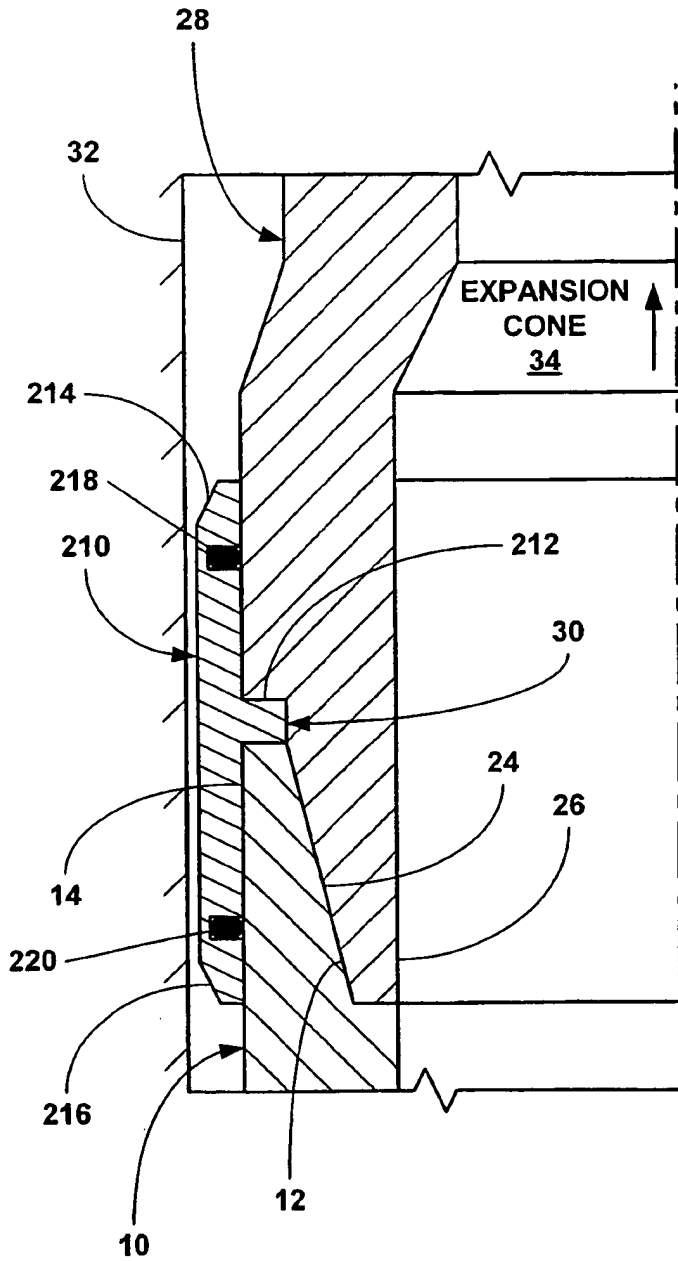

Fig. 3b

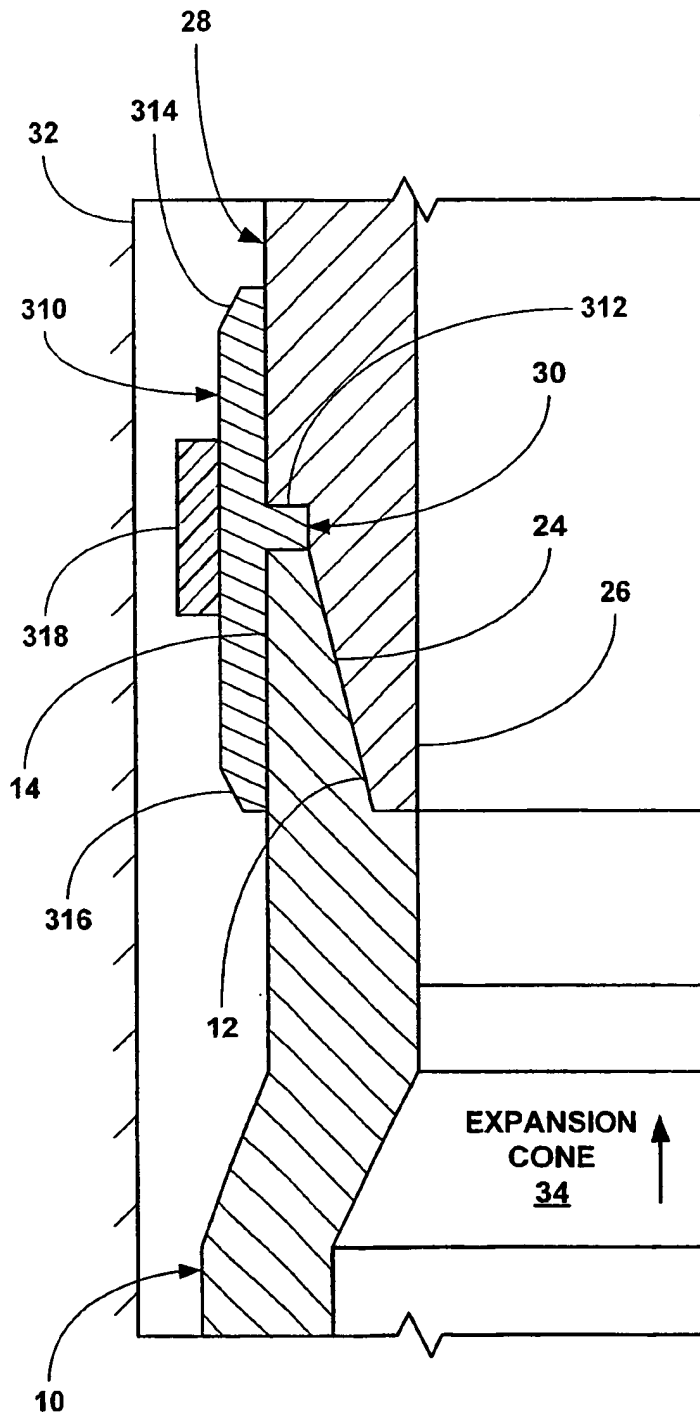

Fig. 4a

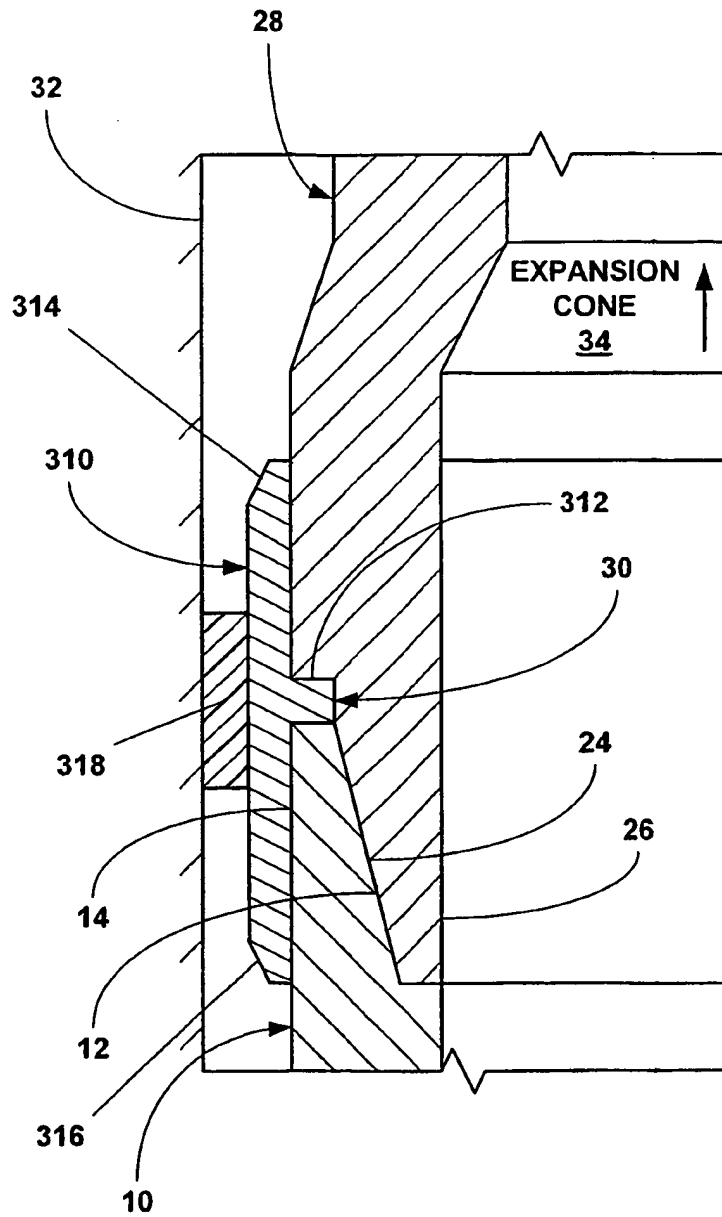

Fig. 4b

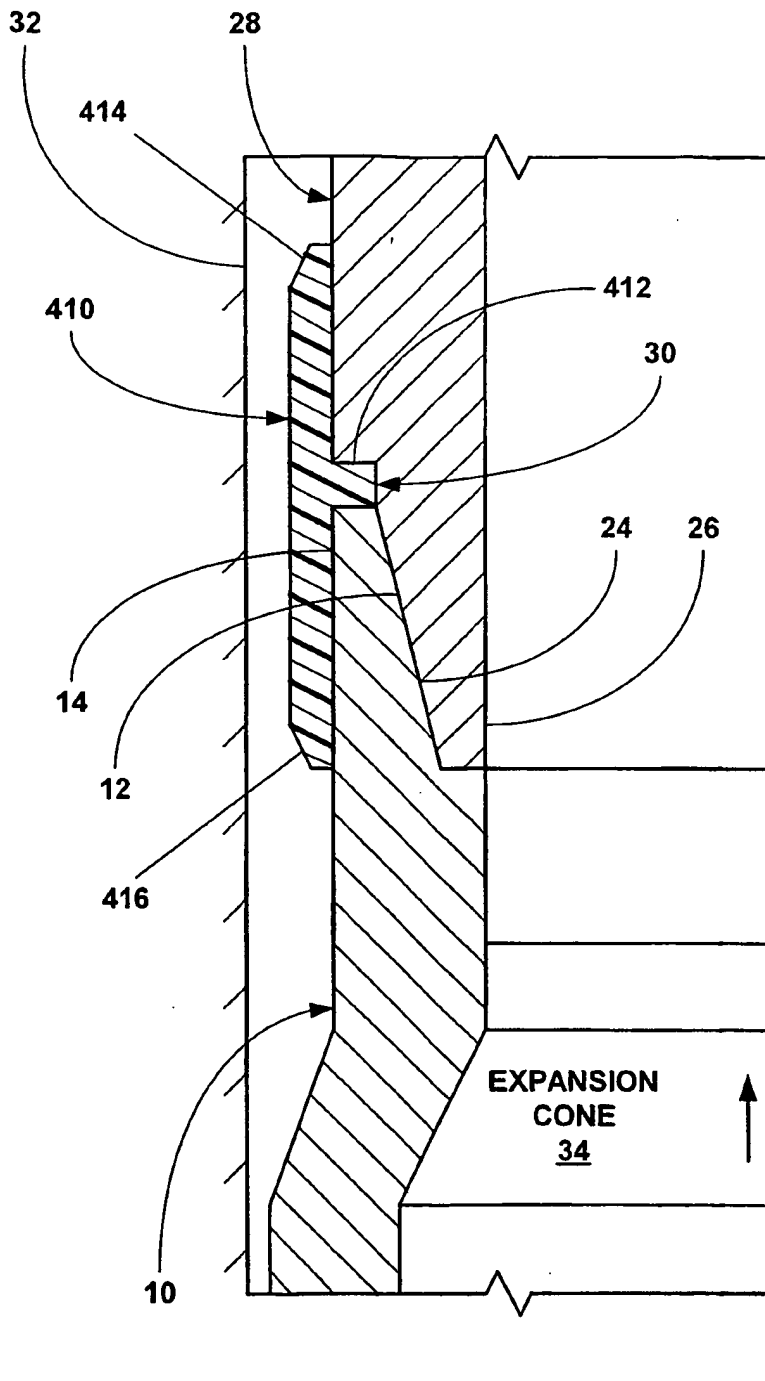

Fig. 5a

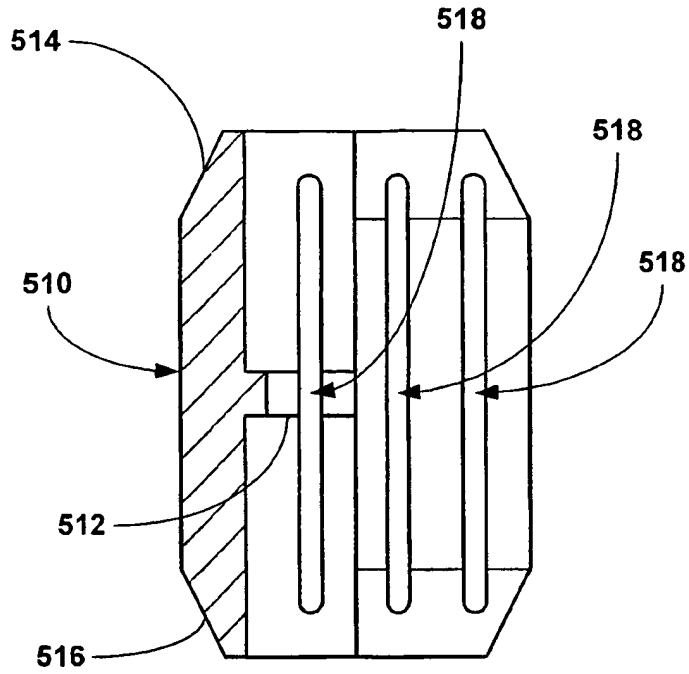

Fig. 6a

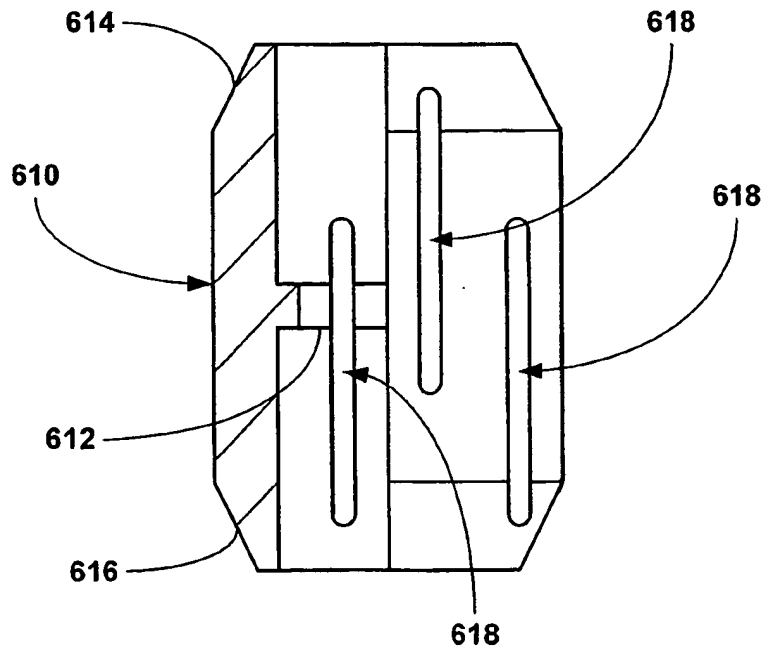

Fig. 6b

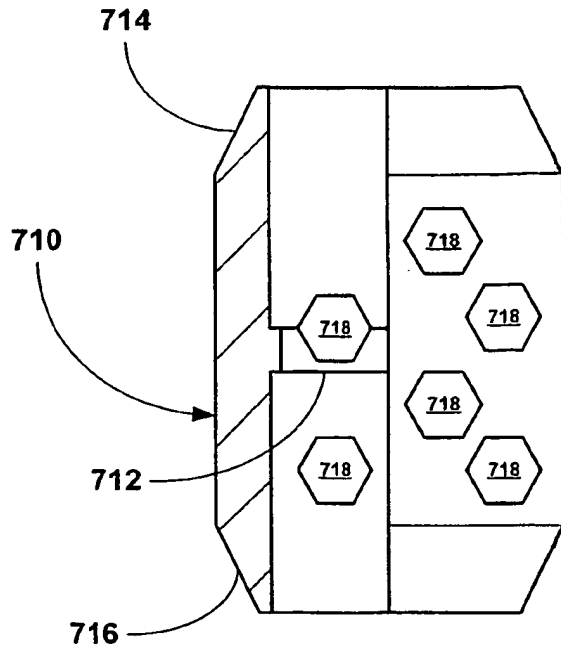

Fig. 6c

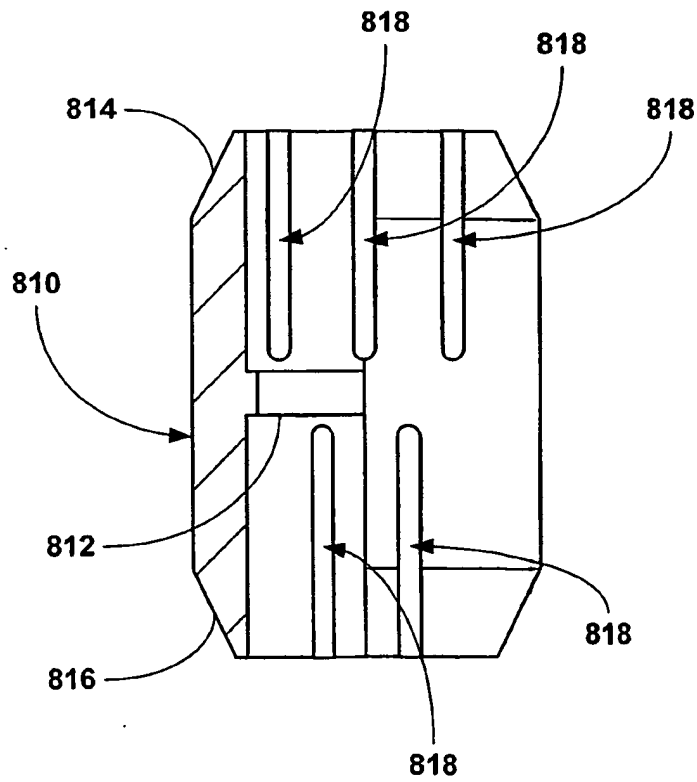

Fig. 6d

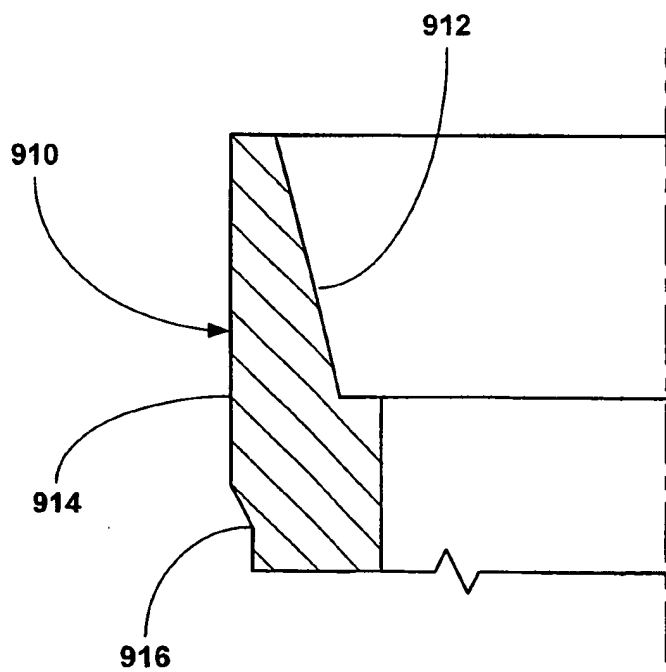

Fig. 7a

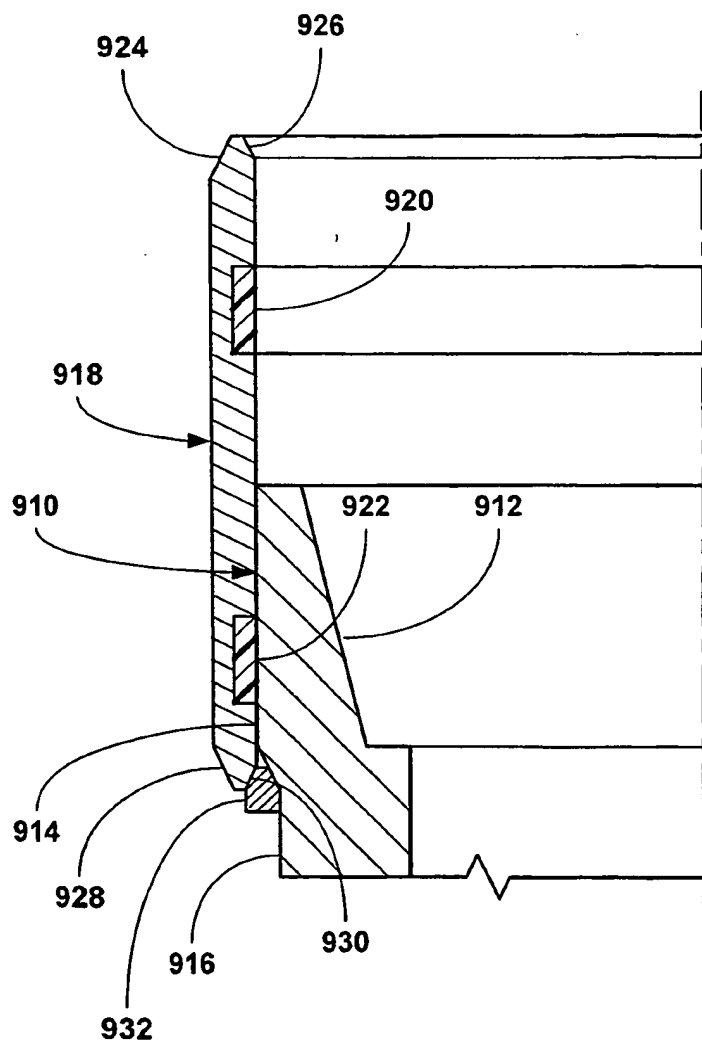

Fig. 7b

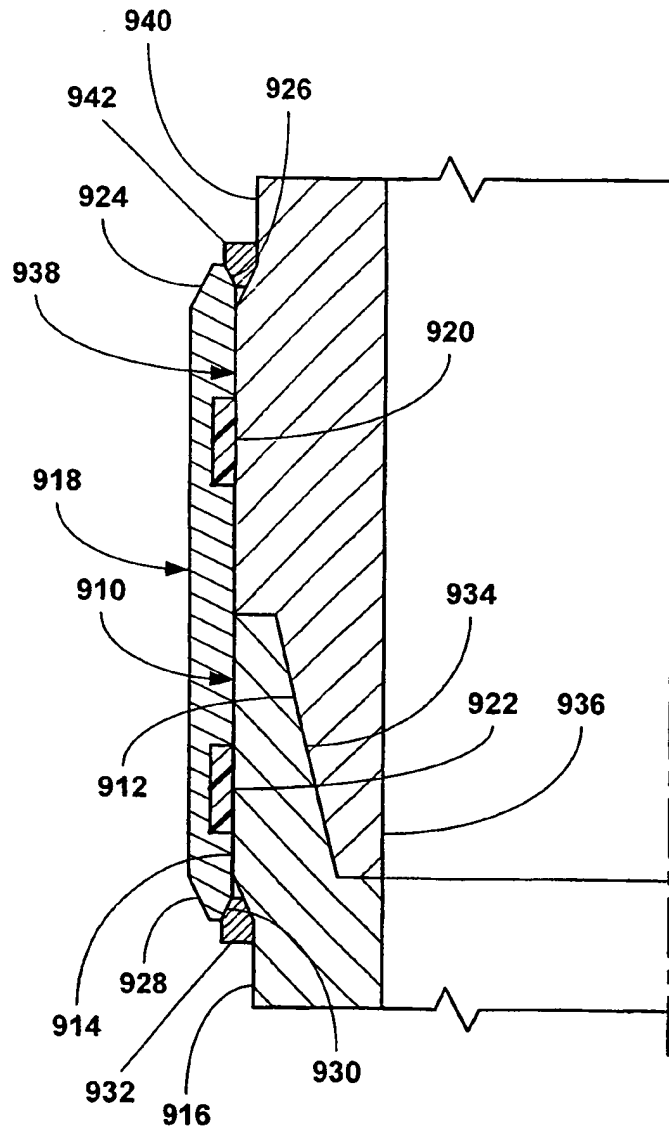

Fig. 7c

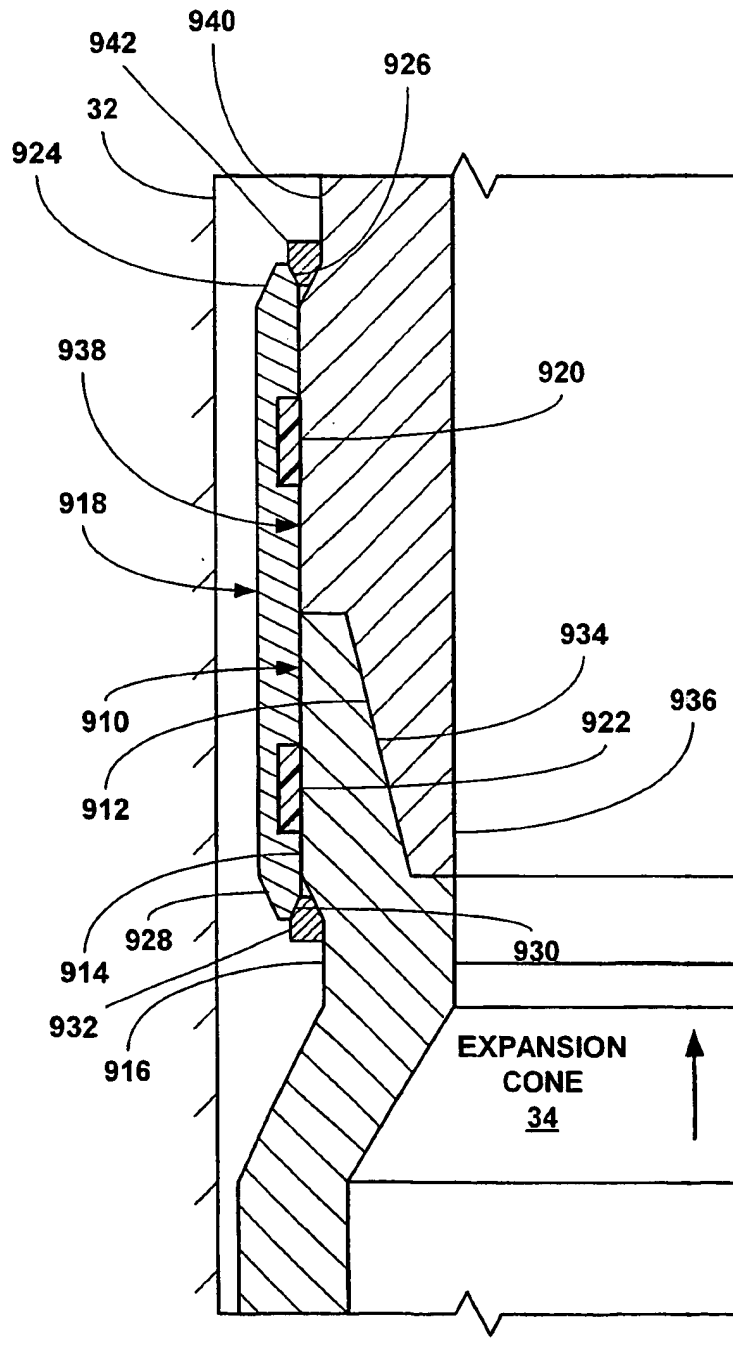

Fig. 7d

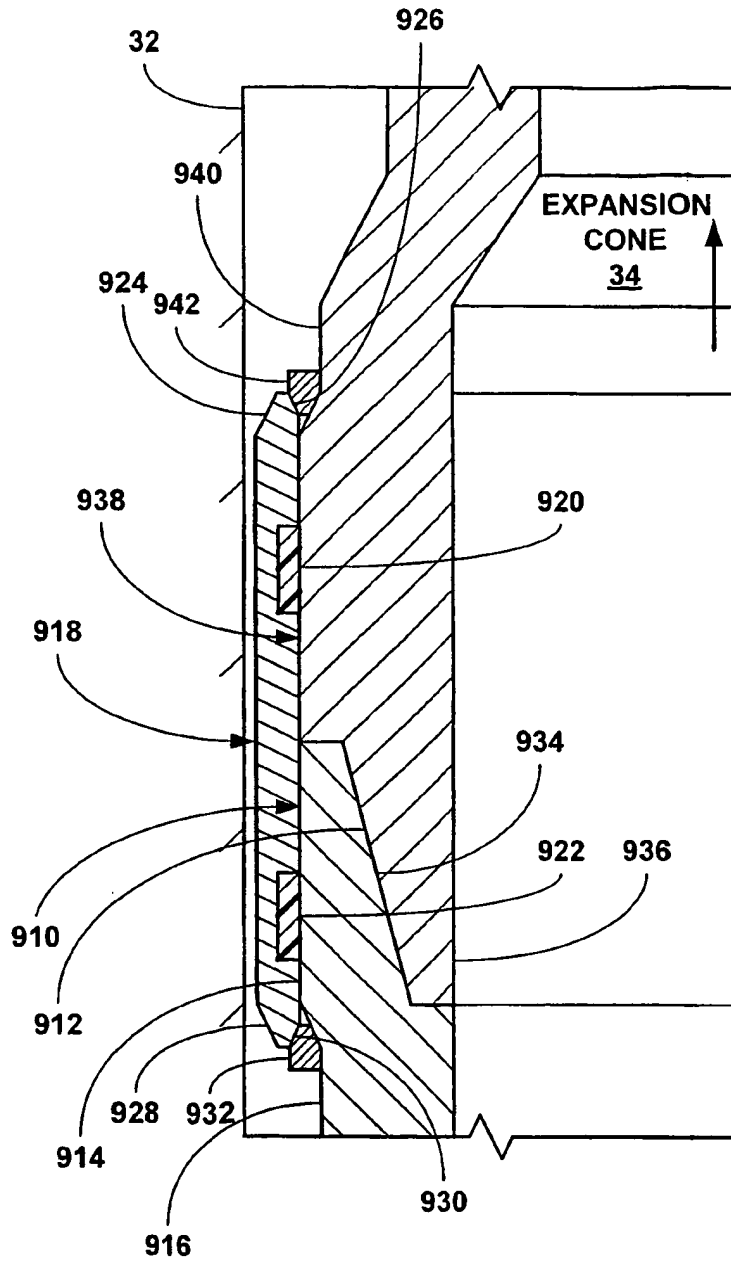

Fig. 7e

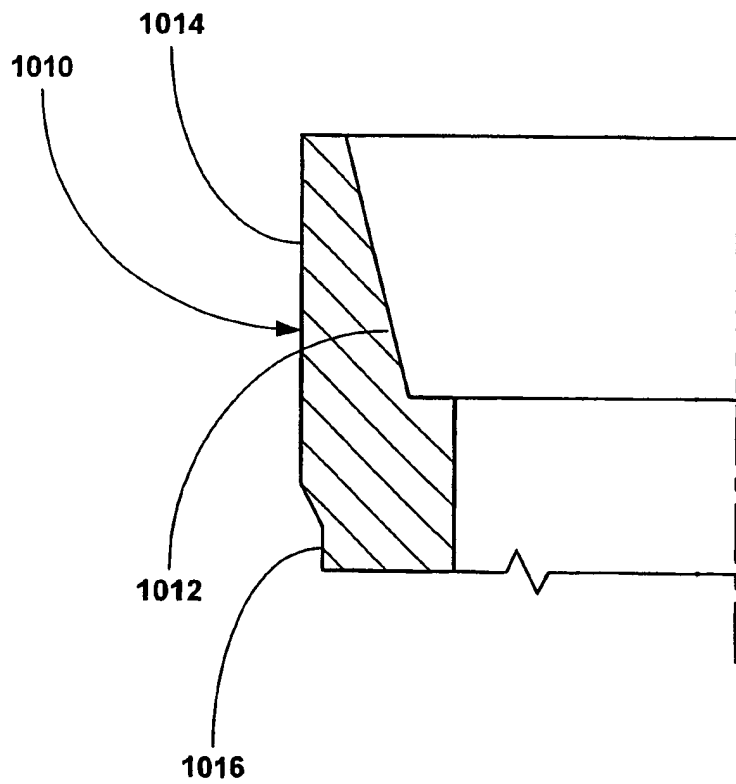

Fig. 8a

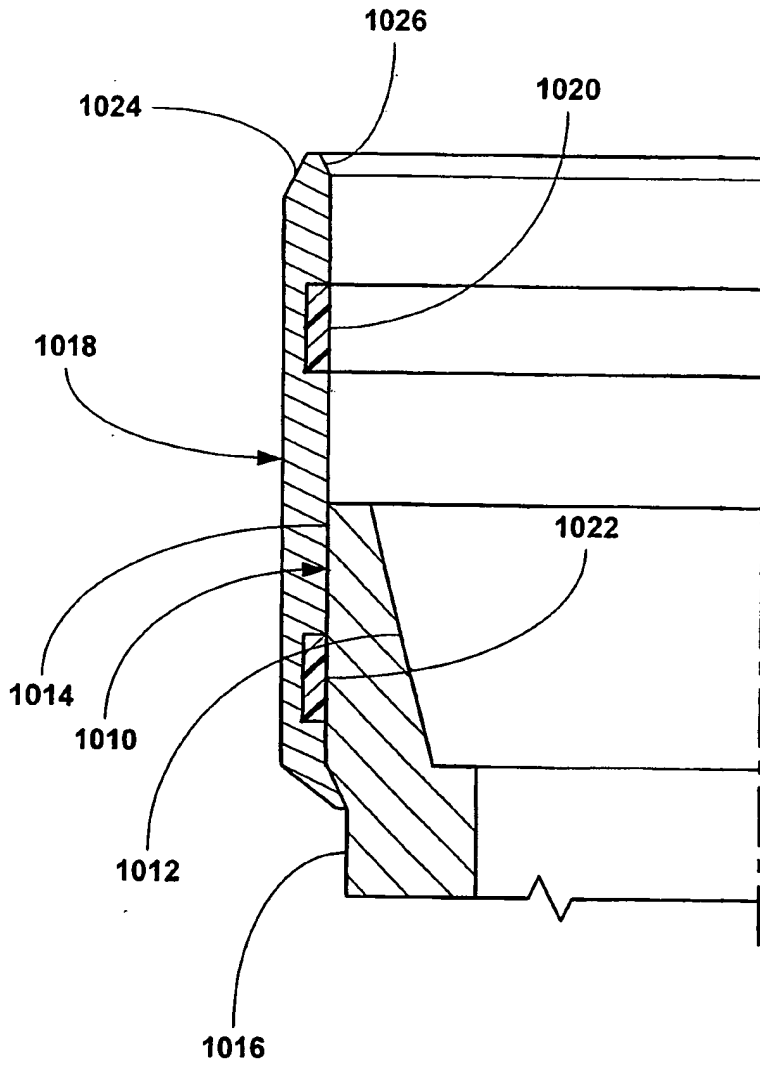

Fig. 8c

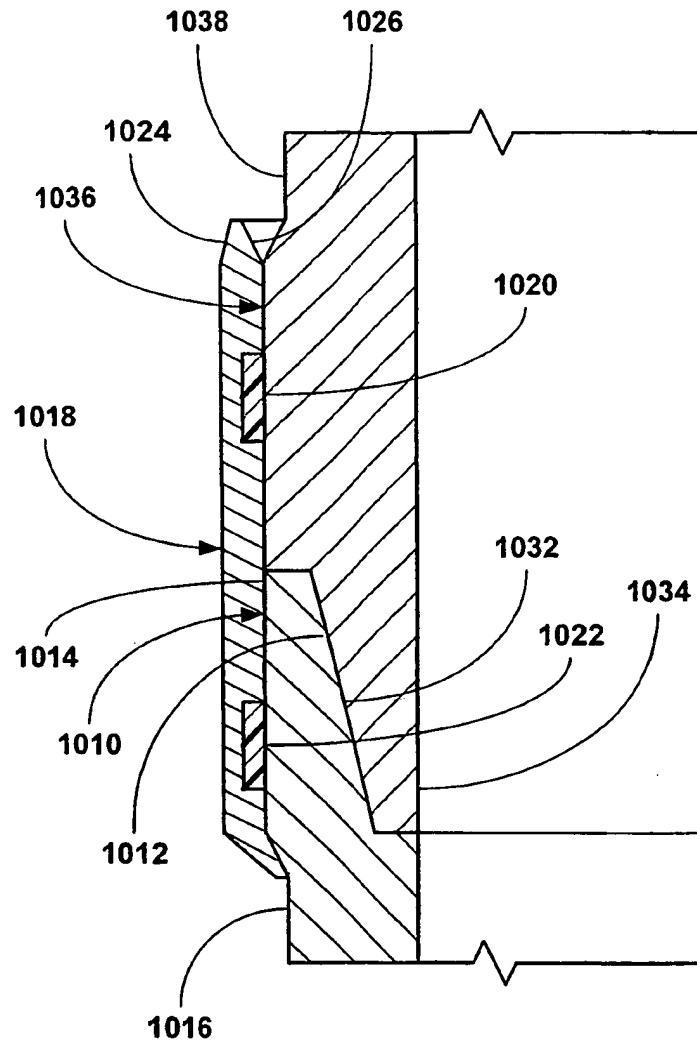

Fig. 8d

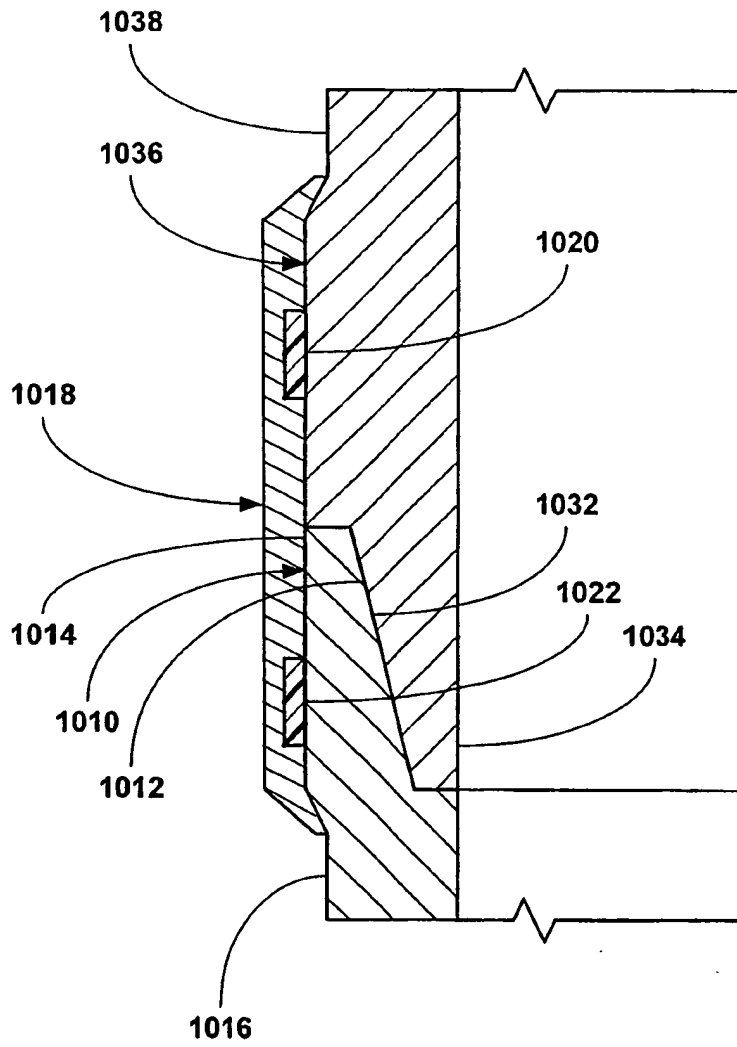

Fig. 8e

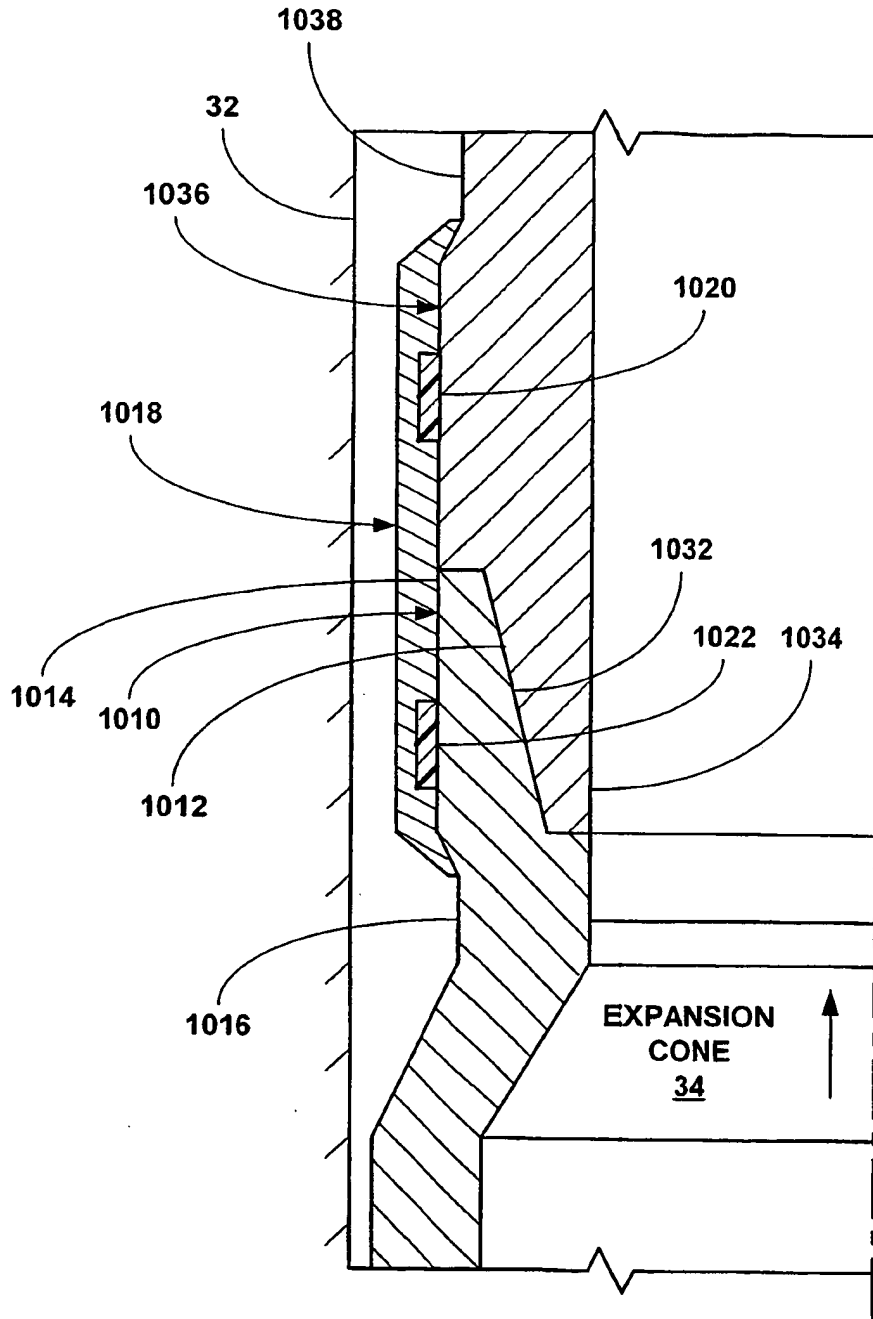

Fig. 8f

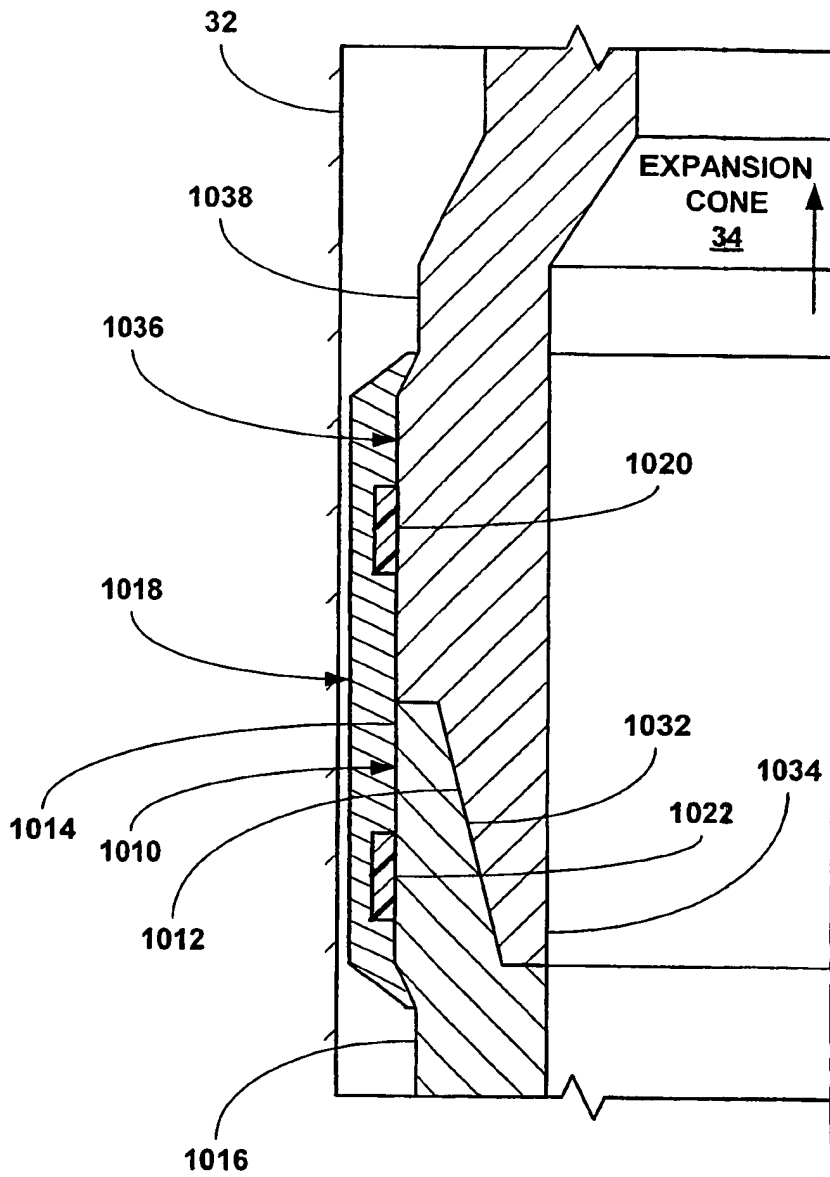

Fig. 8g

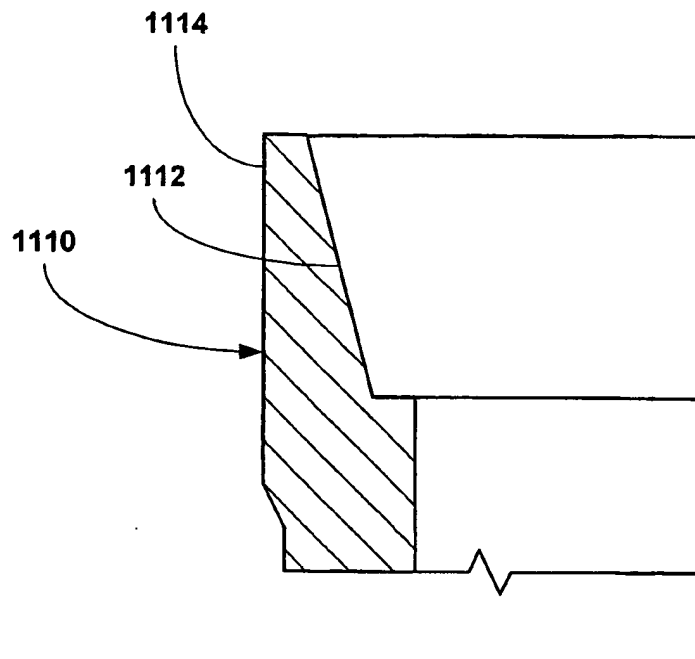

Fig. 9a

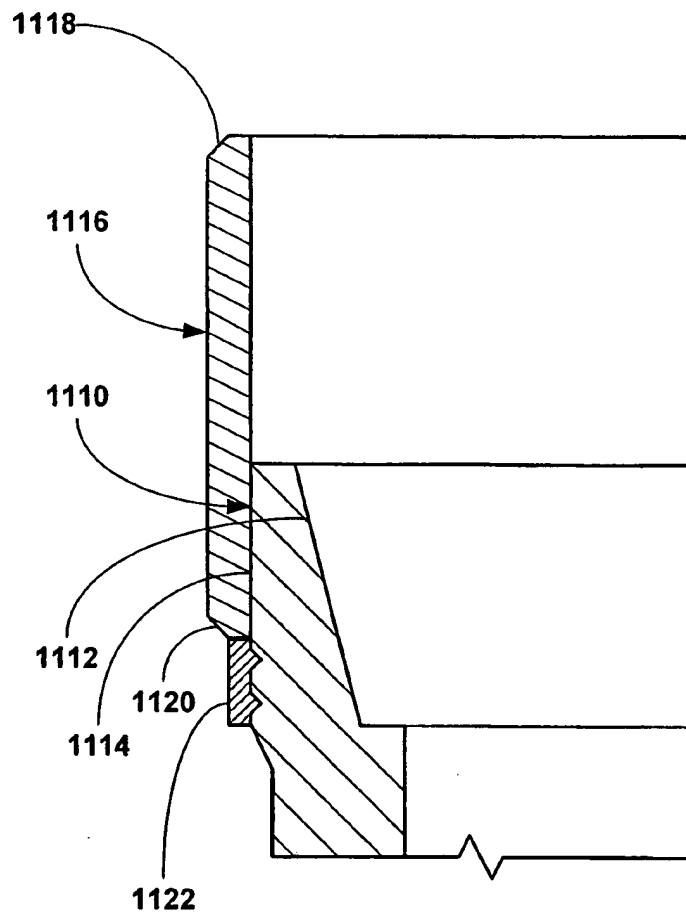

Fig. 9b

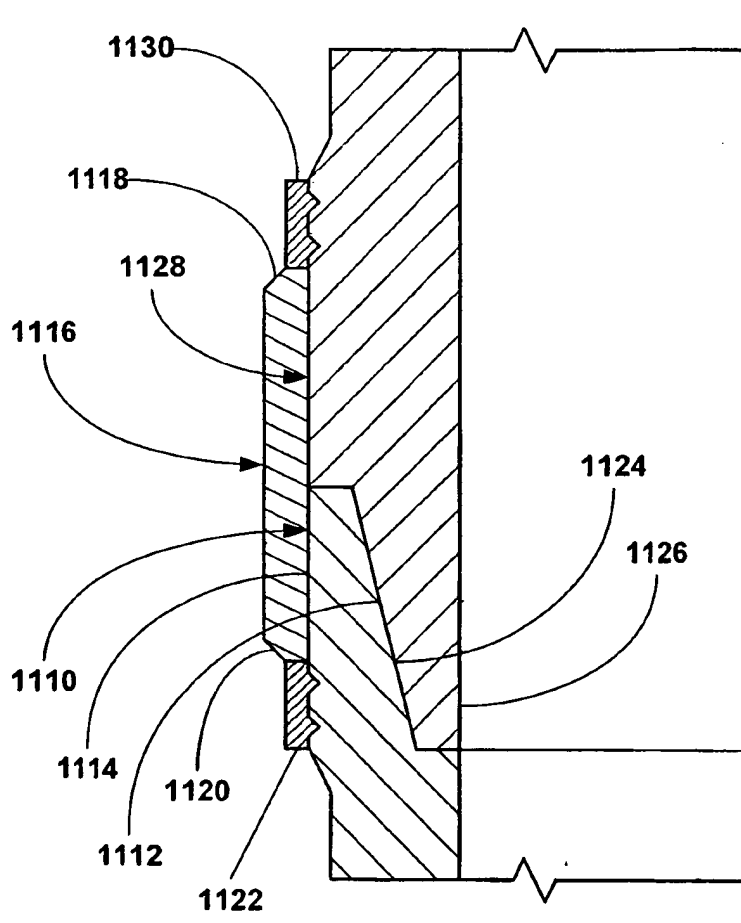

Fig. 9c

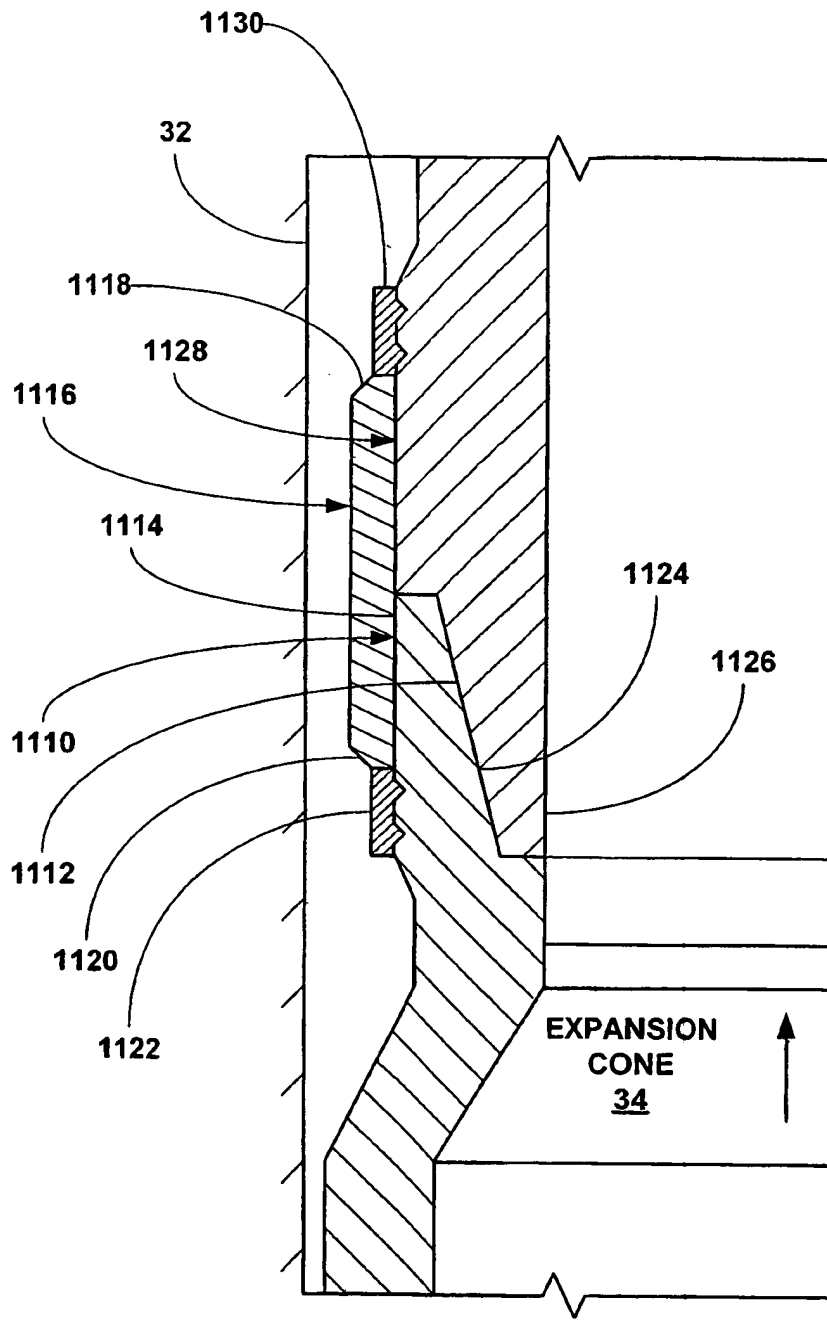

Fig. 9d

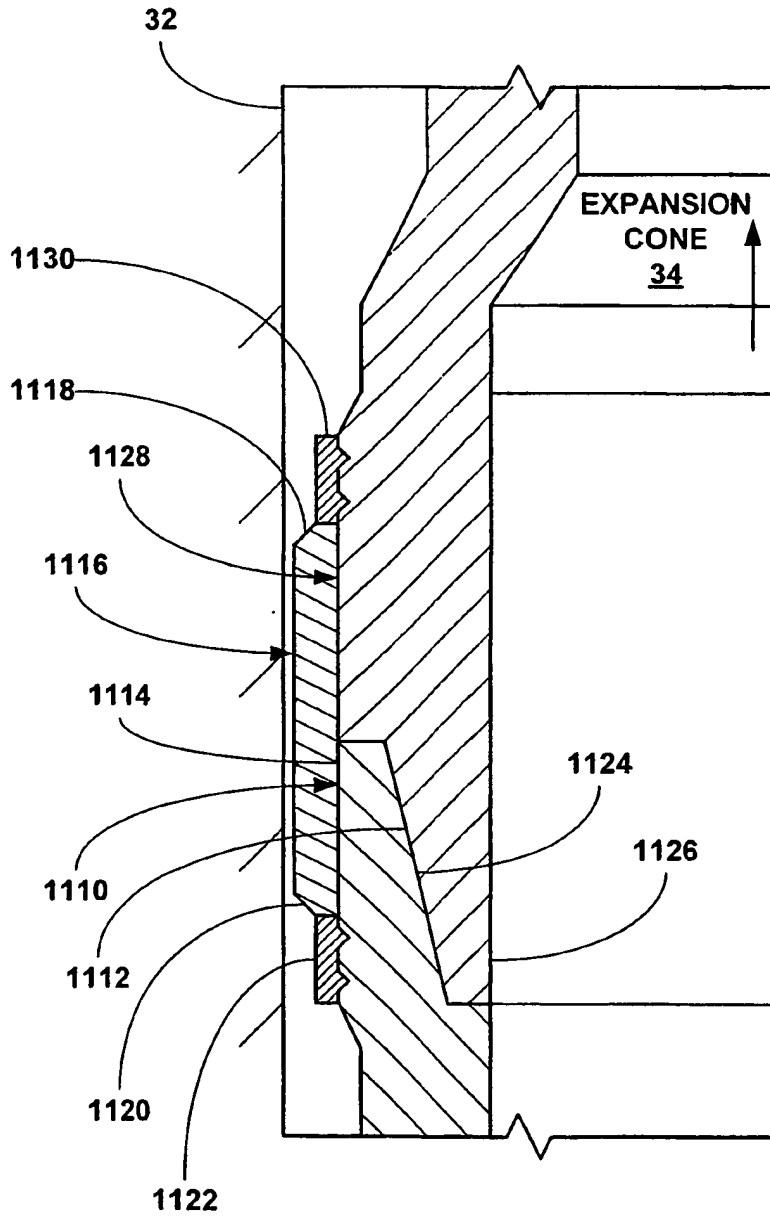

Fig. 9e

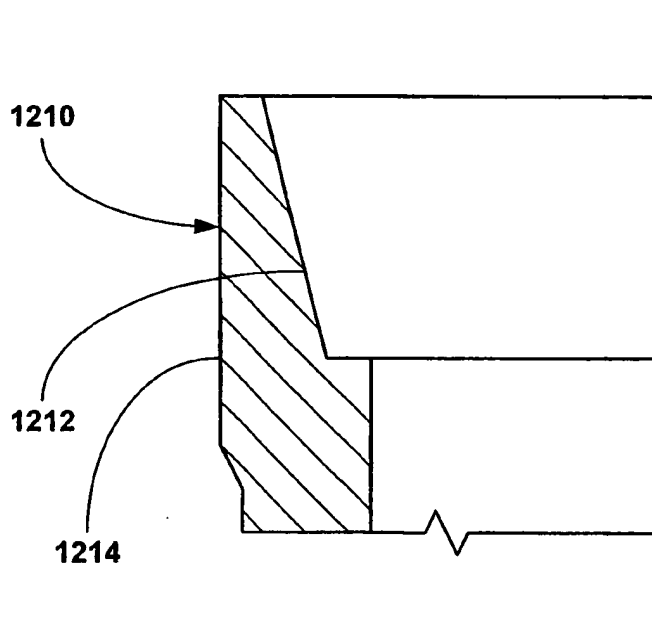

Fig. 10a

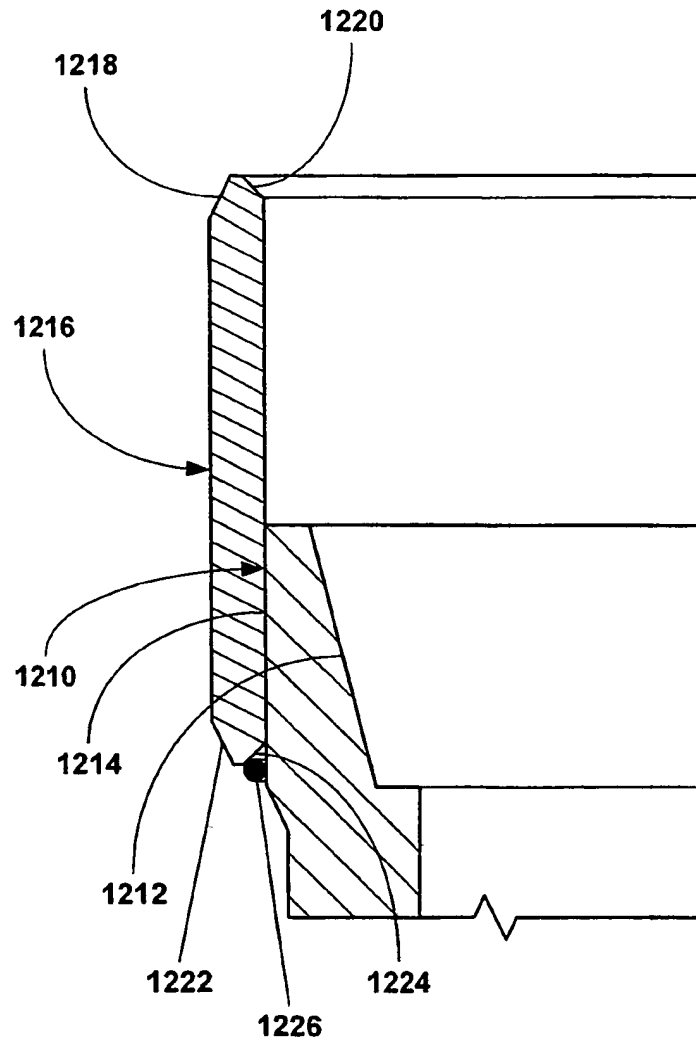

Fig. 10b

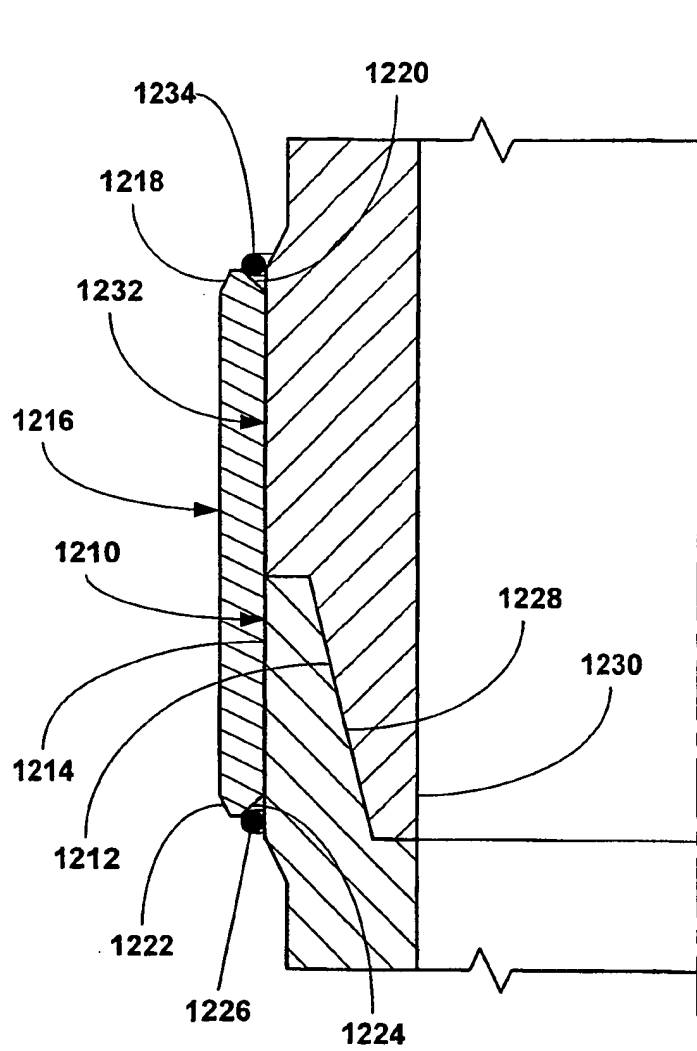

Fig. 10c

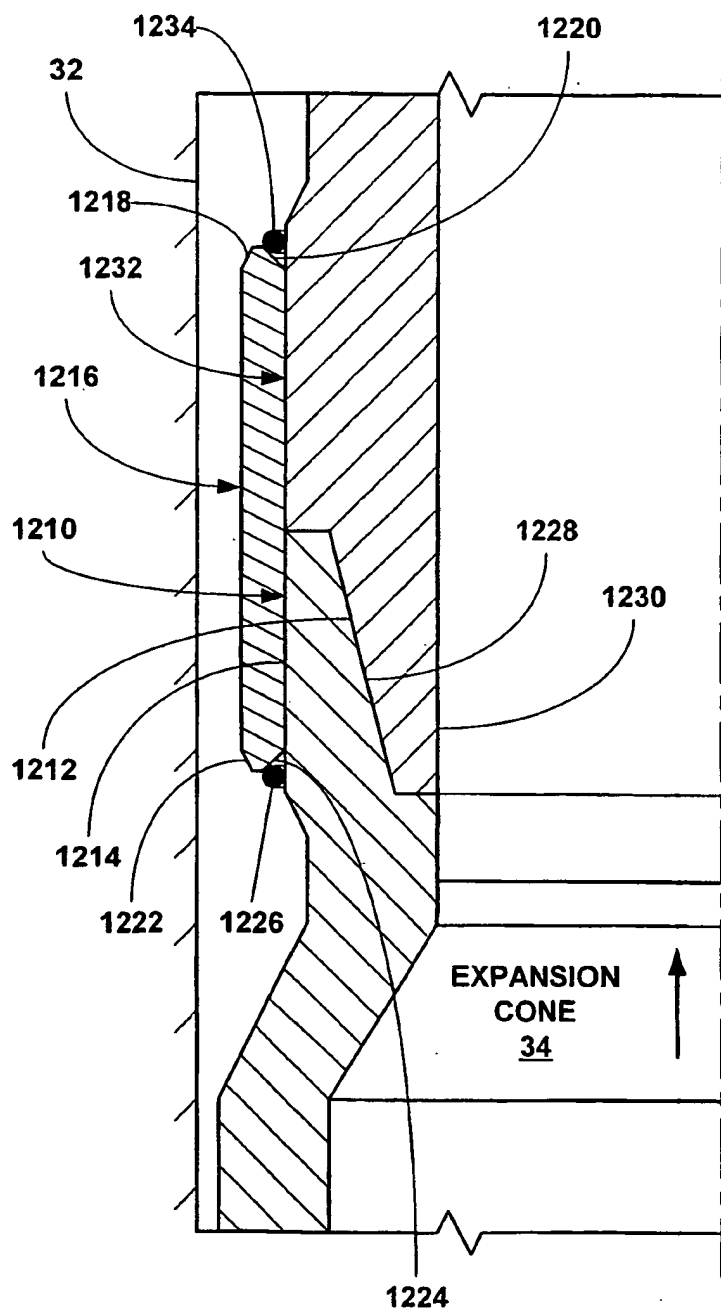

Fig. 10d

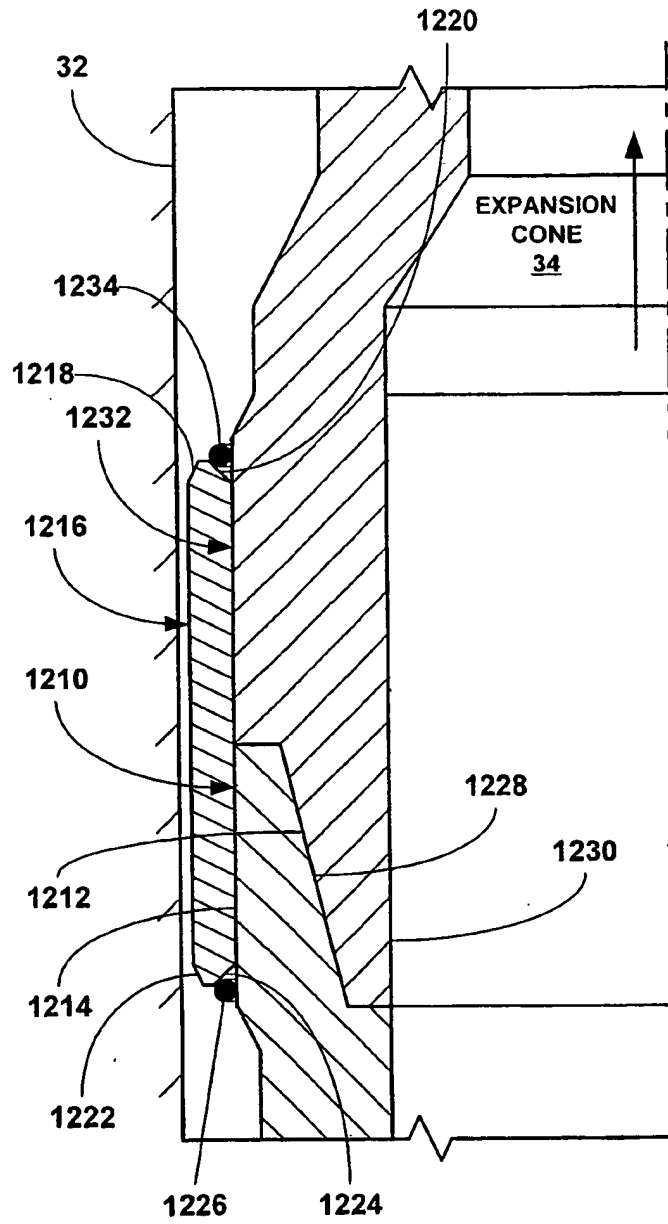

Fig. 10e

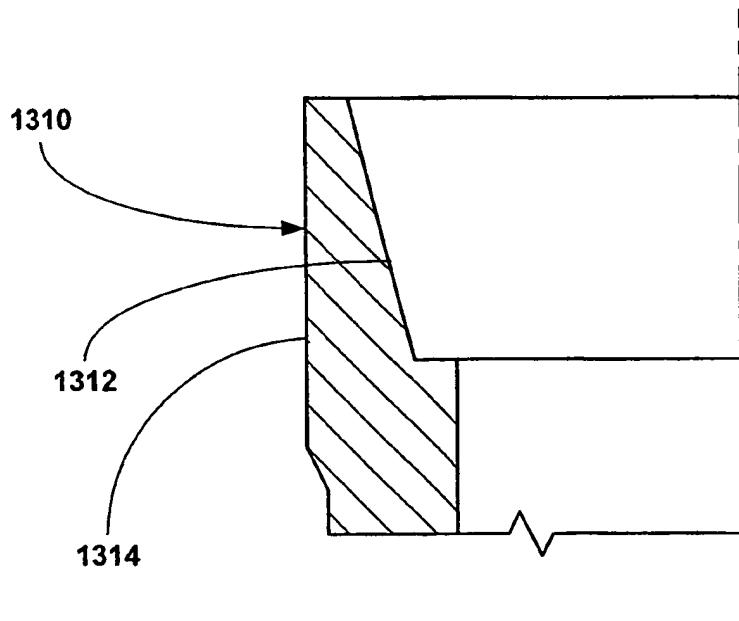

Fig. 11a

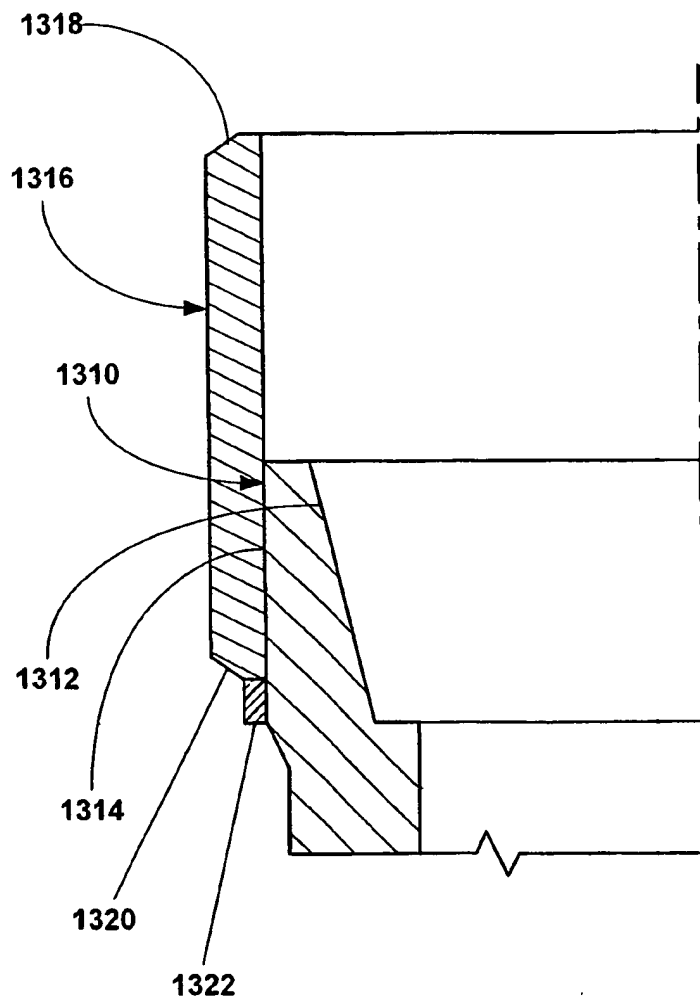

Fig. 11b

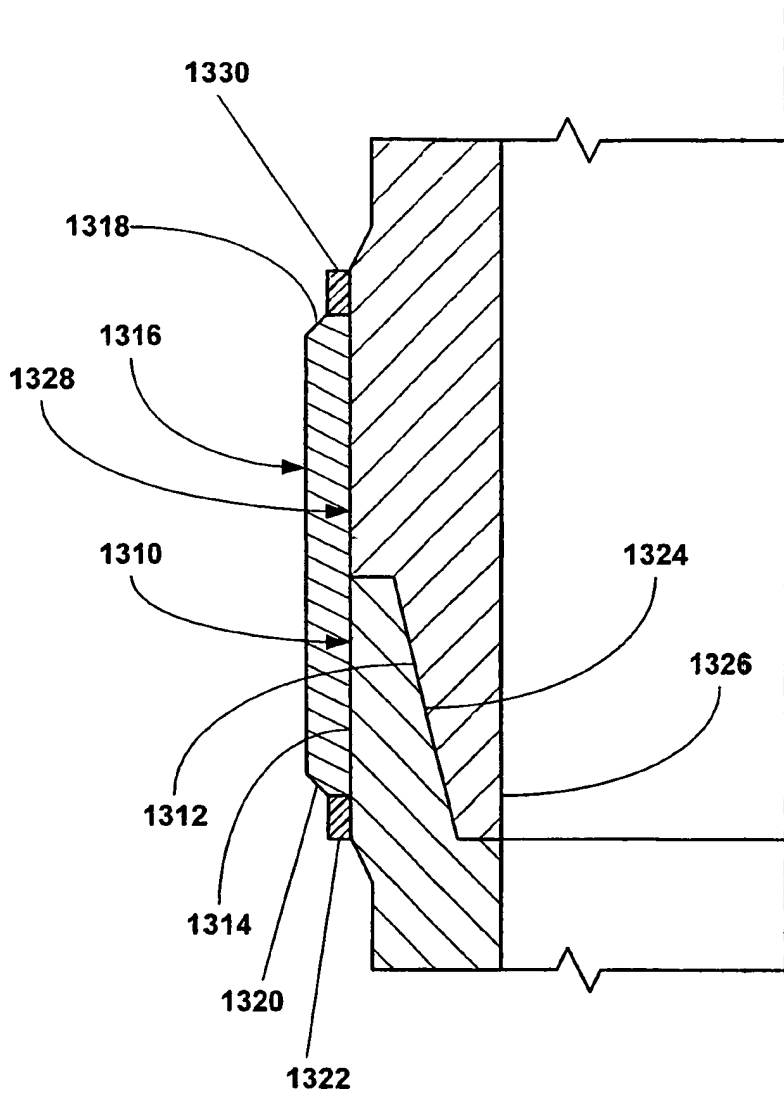

Fig. 11c

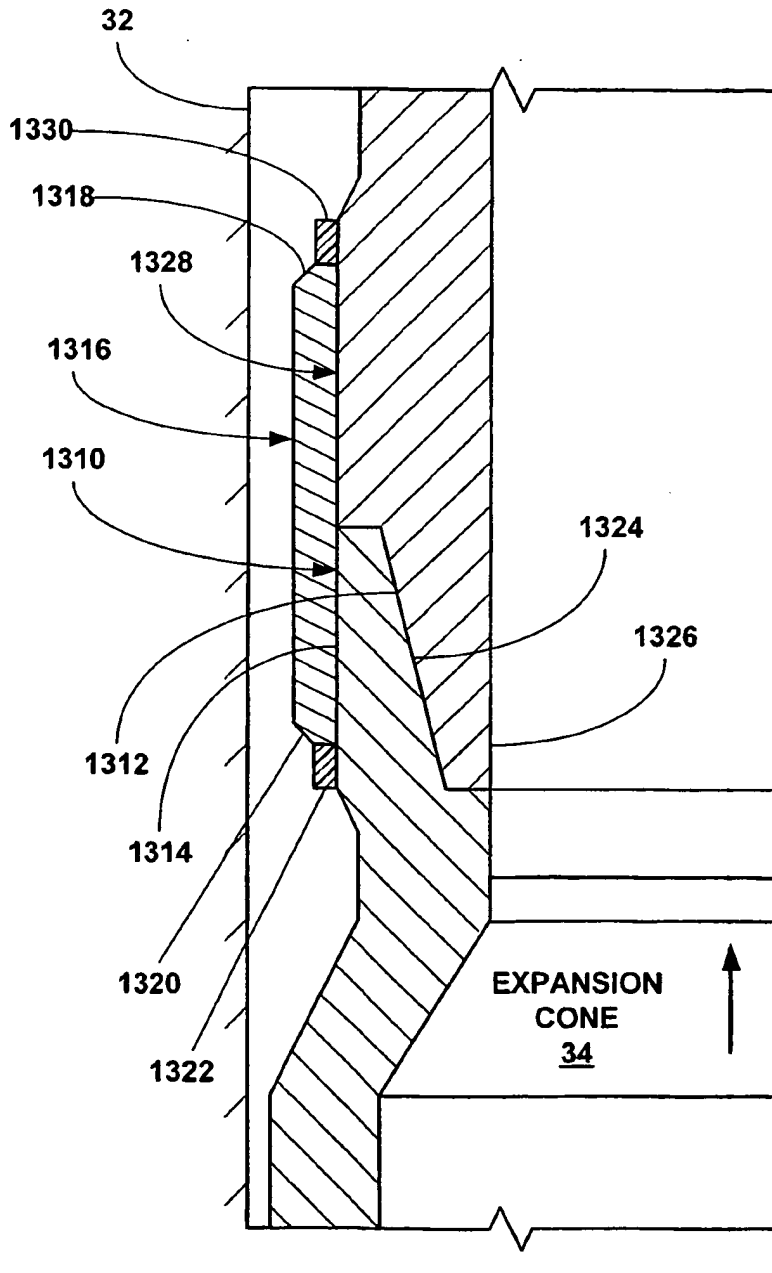

Fig. 11d

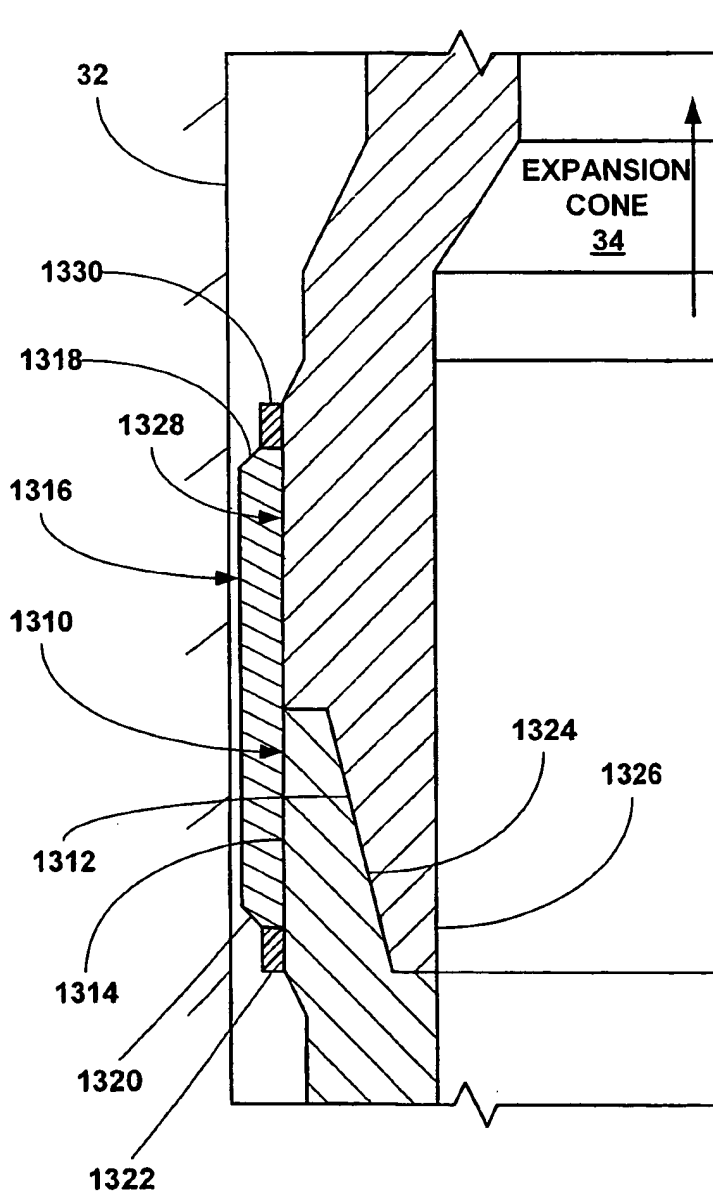

Fig. 11e

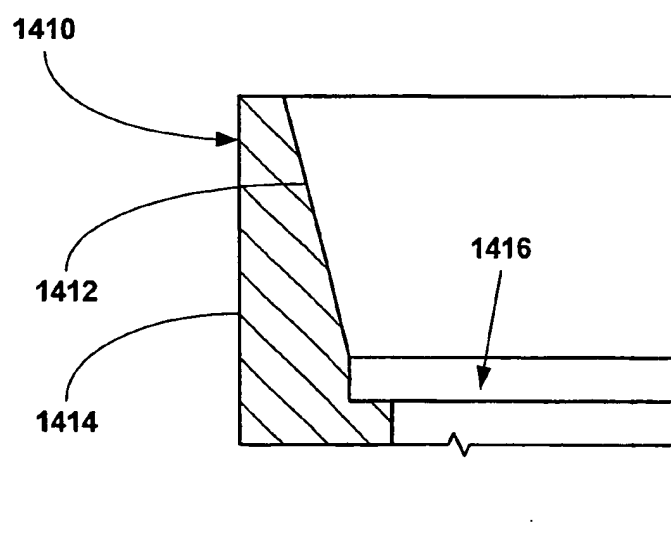

Fig. 12a

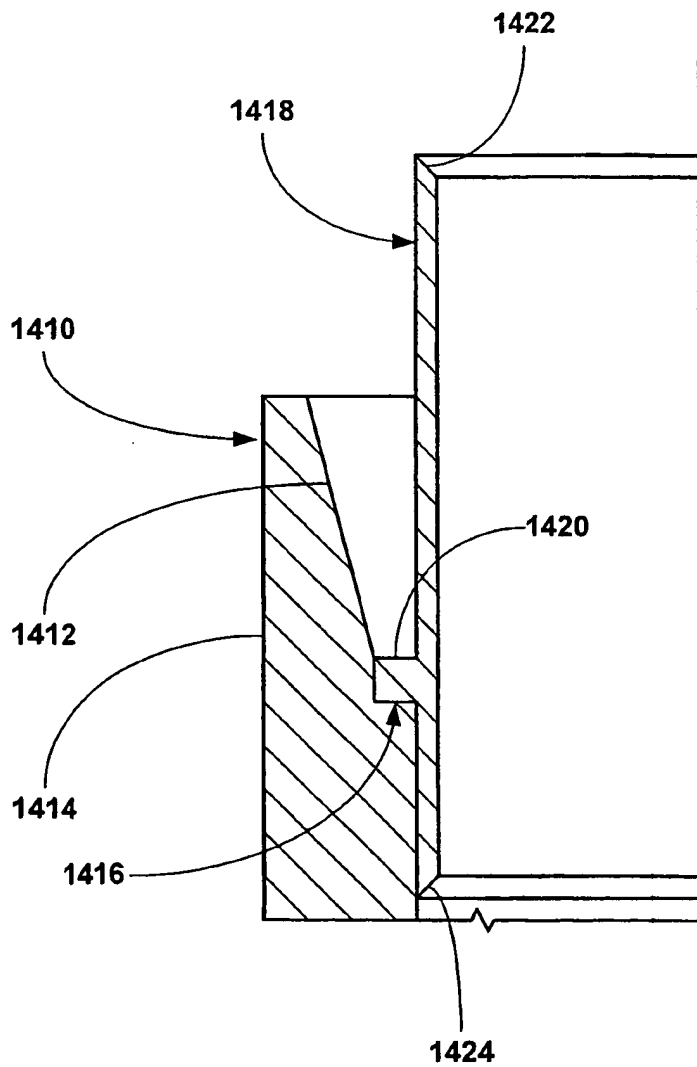

Fig. 12b

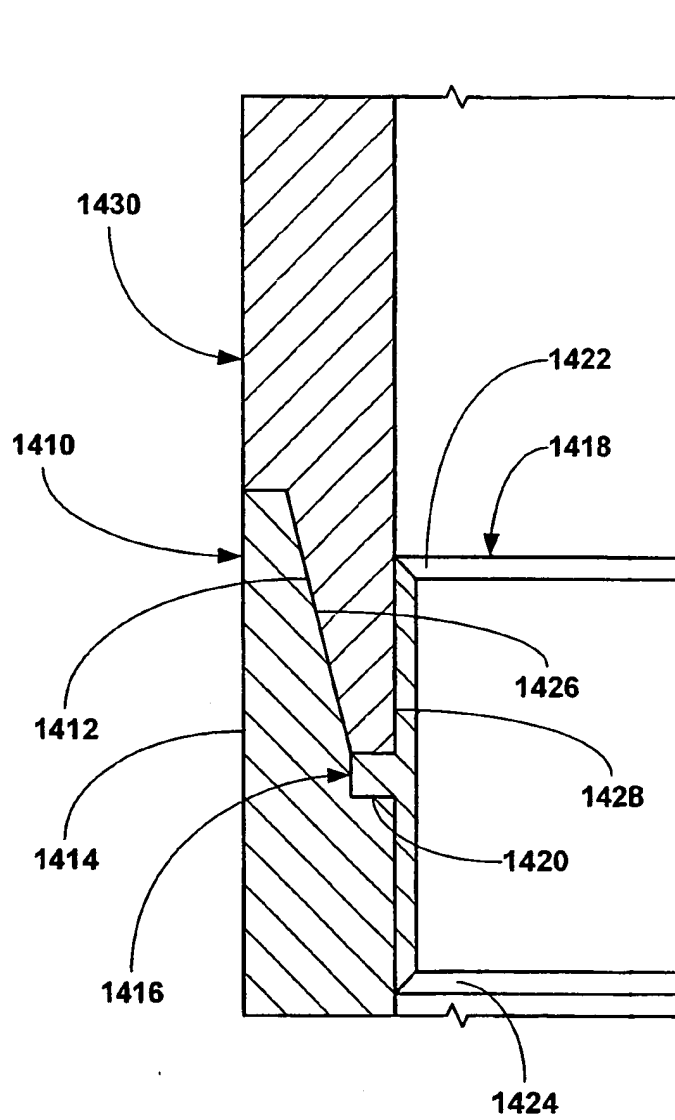

Fig. 12c

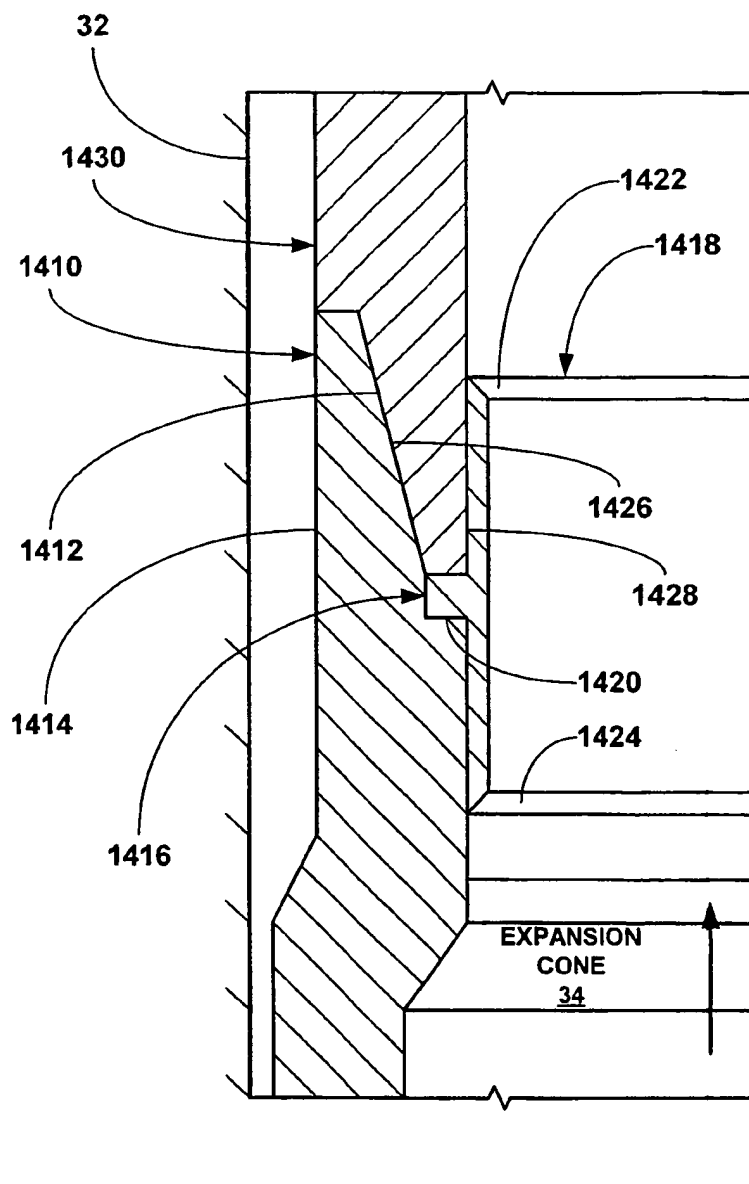

Fig. 12d

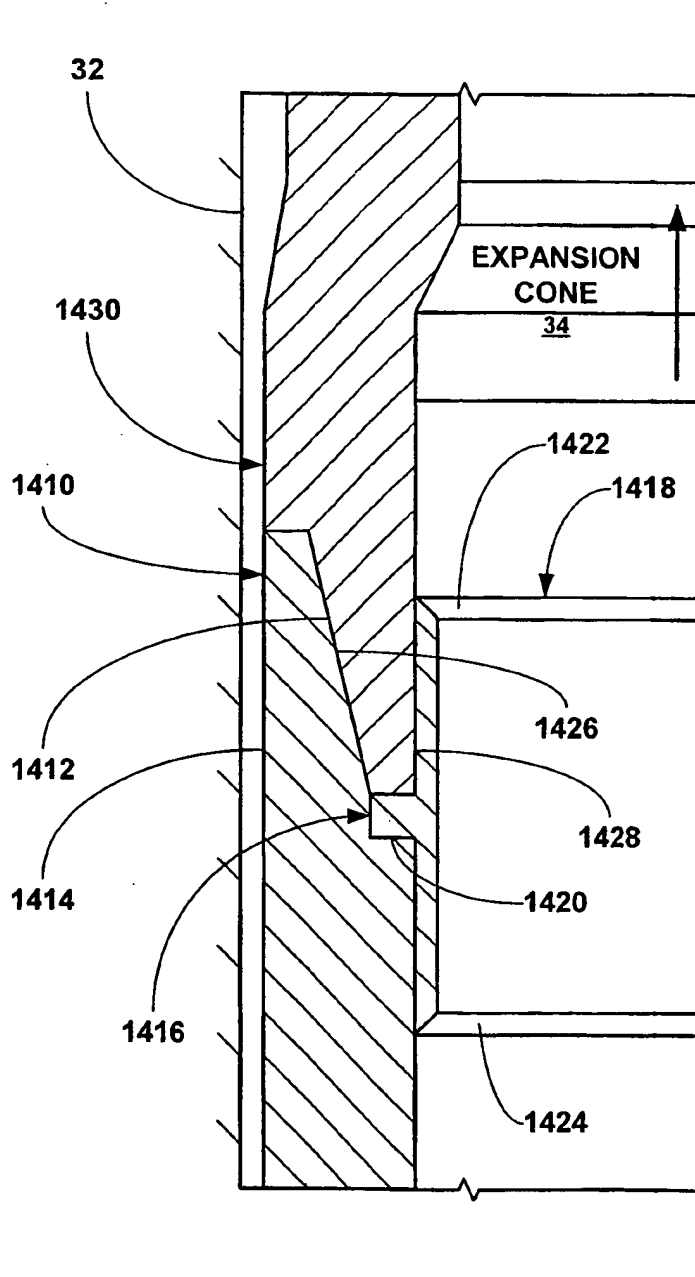

Fig. 12

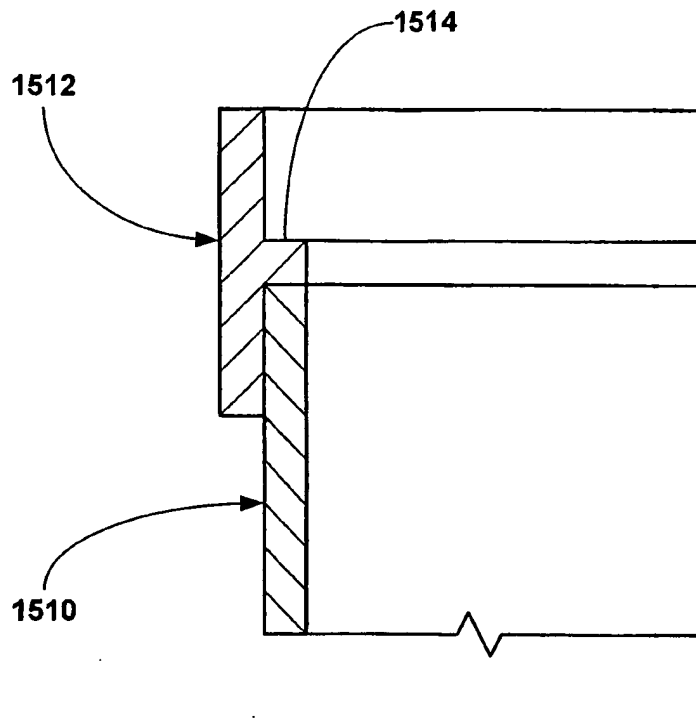

Fig. 13a

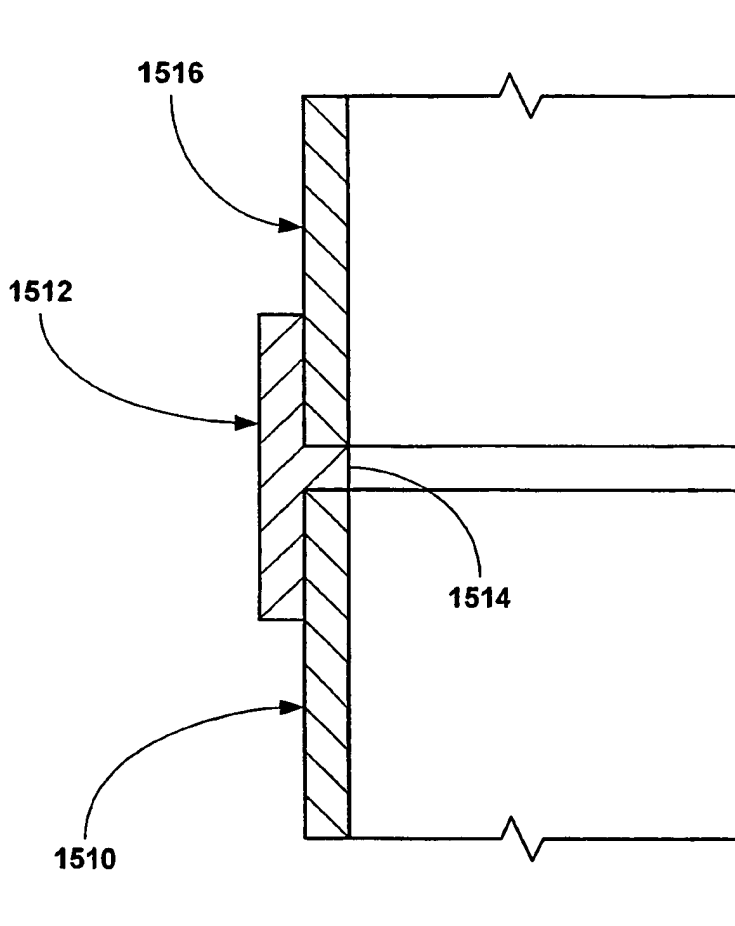

Fig. 13b

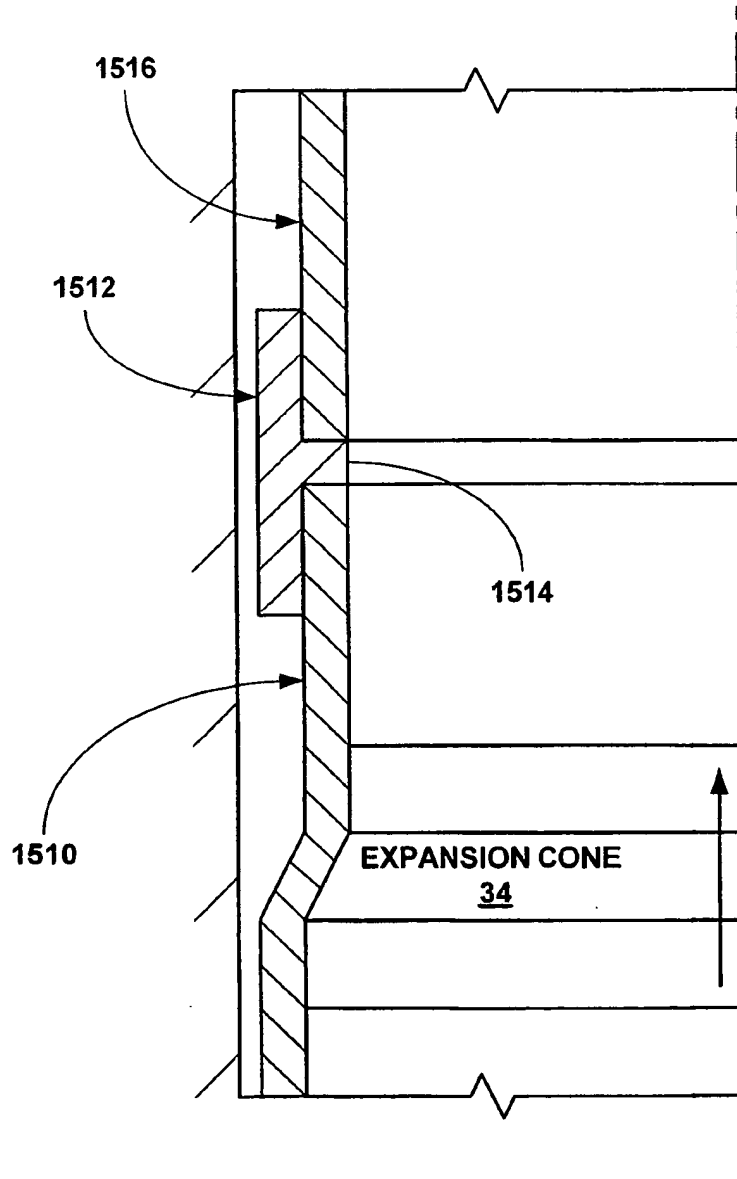

Fig. 13c

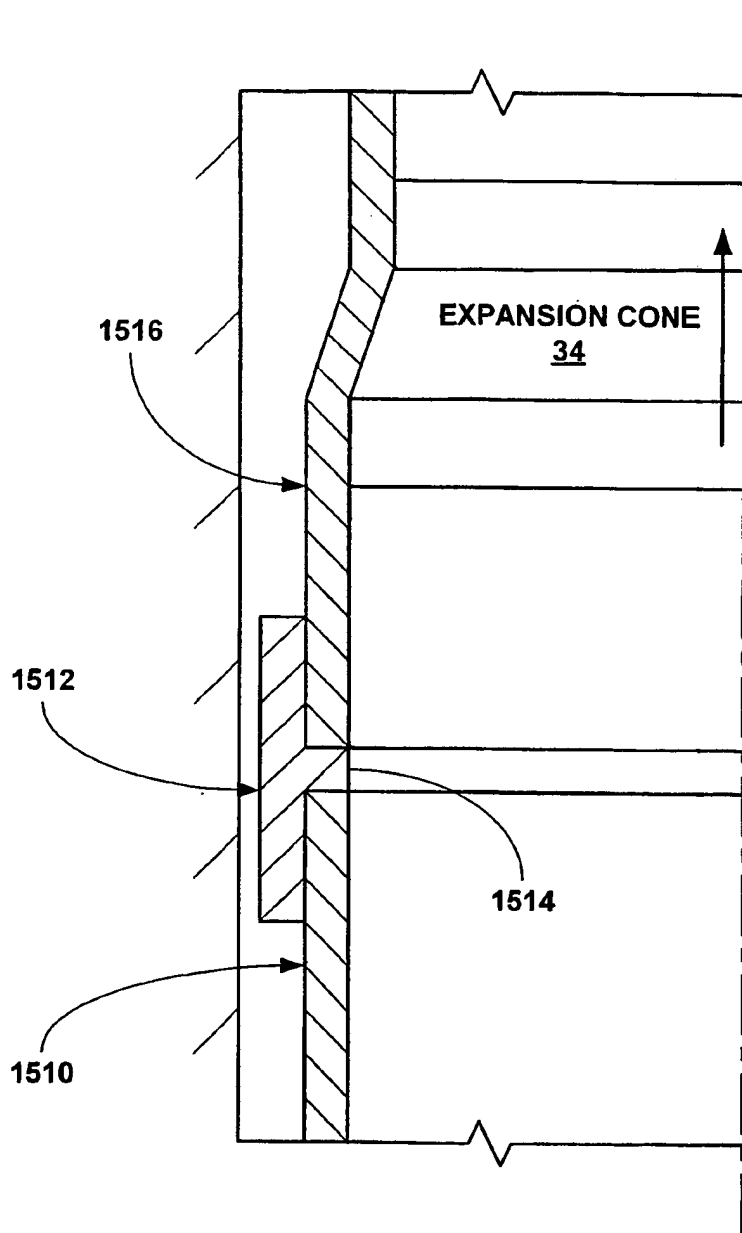

Fig. 13d

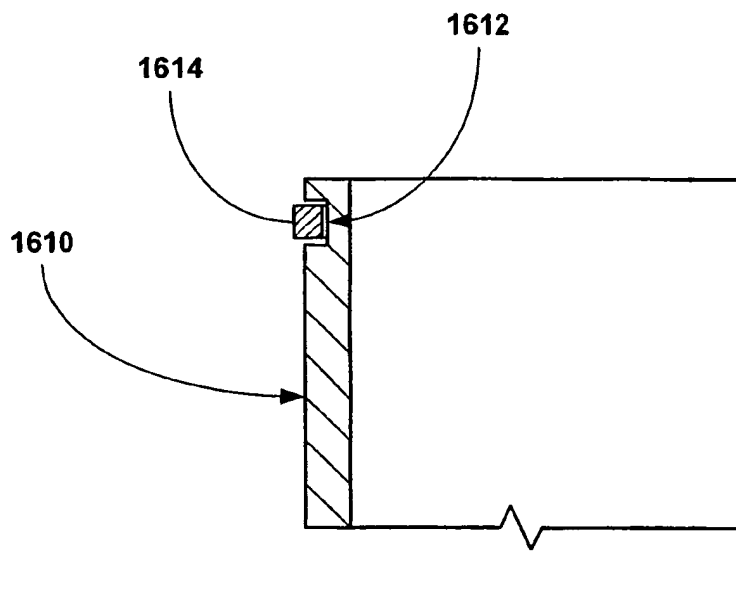

Fig. 14a

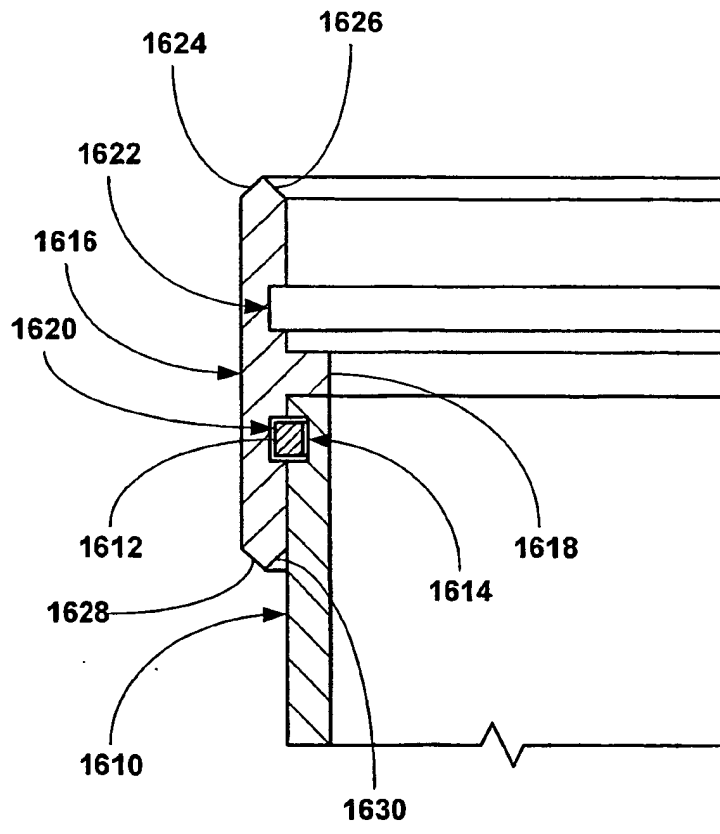

Fig. 14b

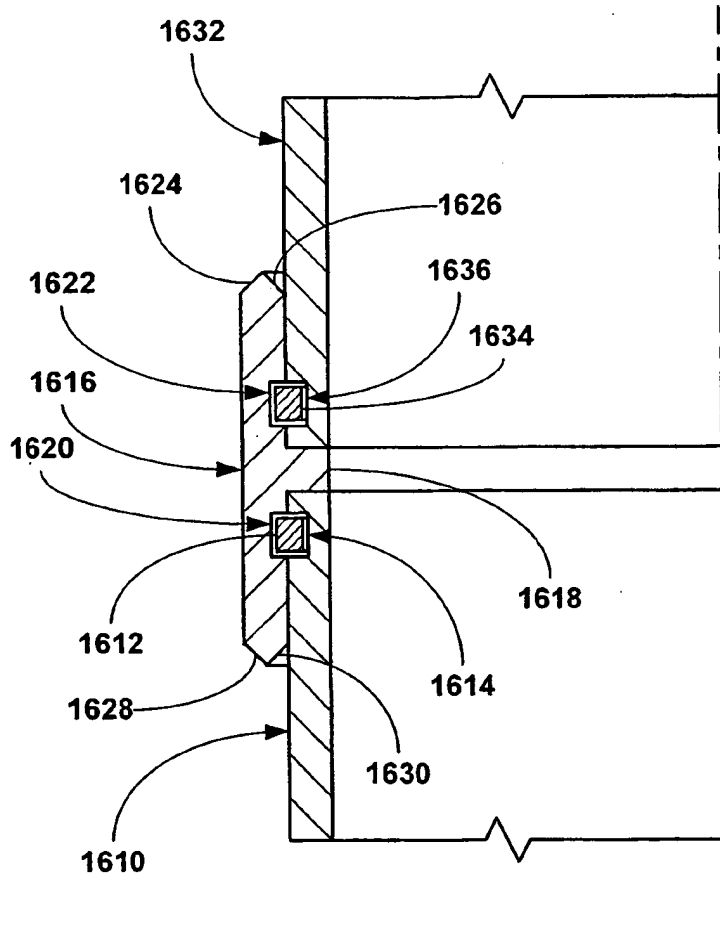

Fig. 14c

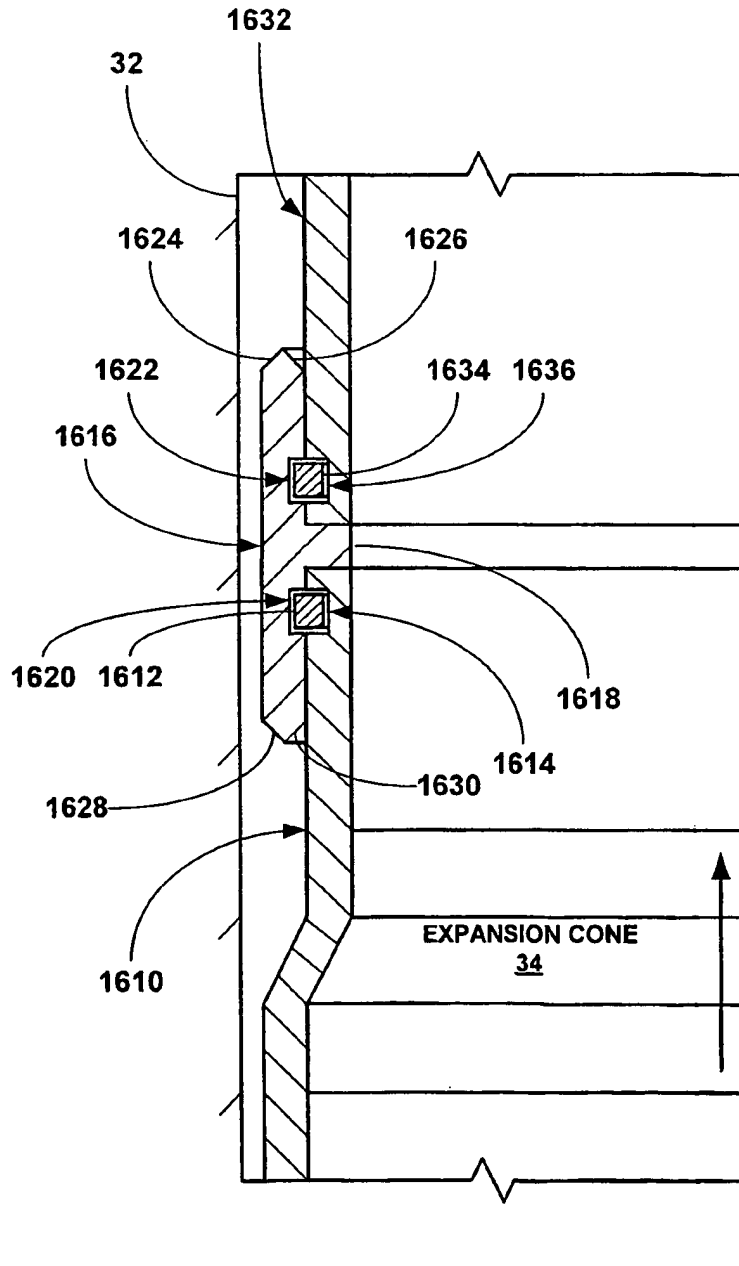

Fig. 14d

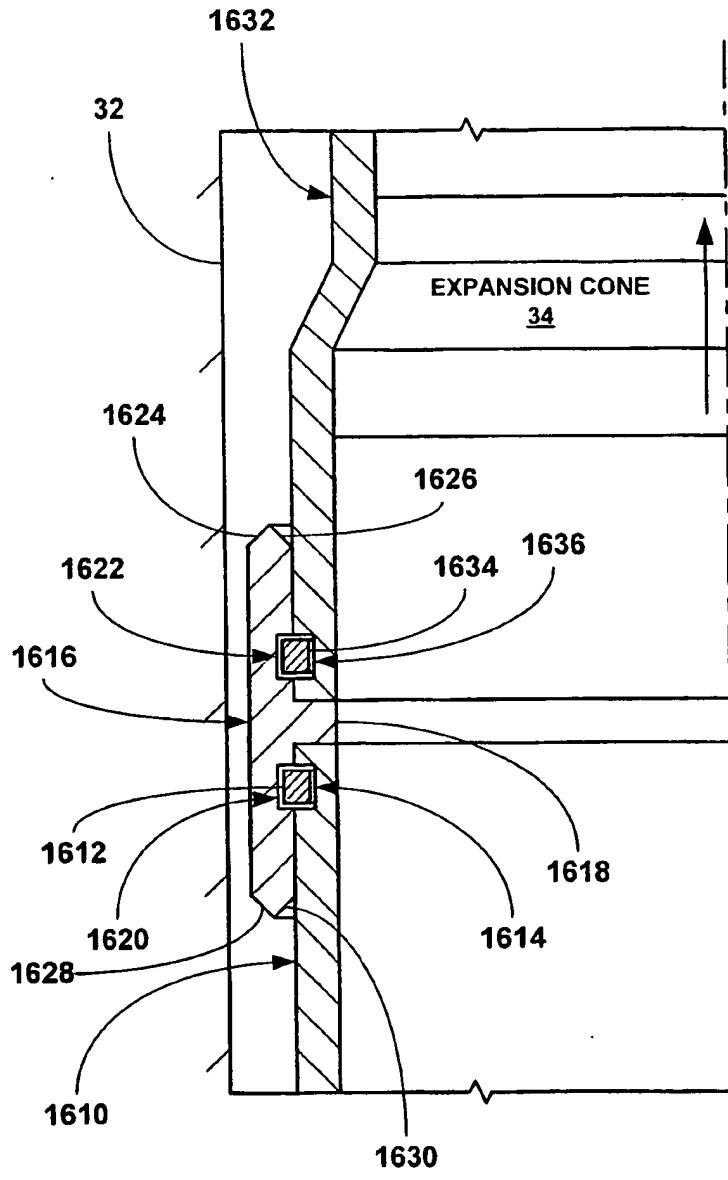

Fig. 14

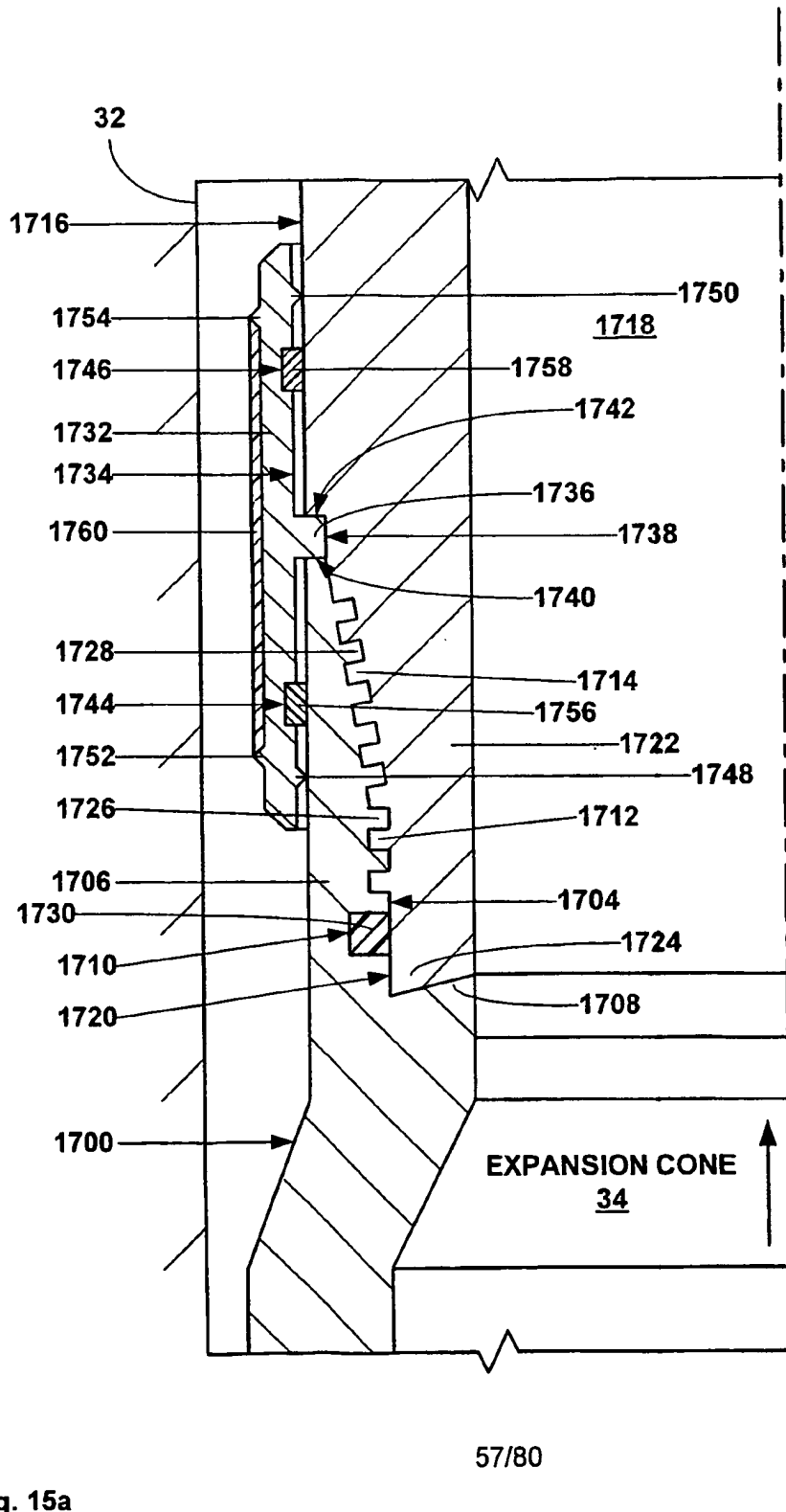

Fig. 15a

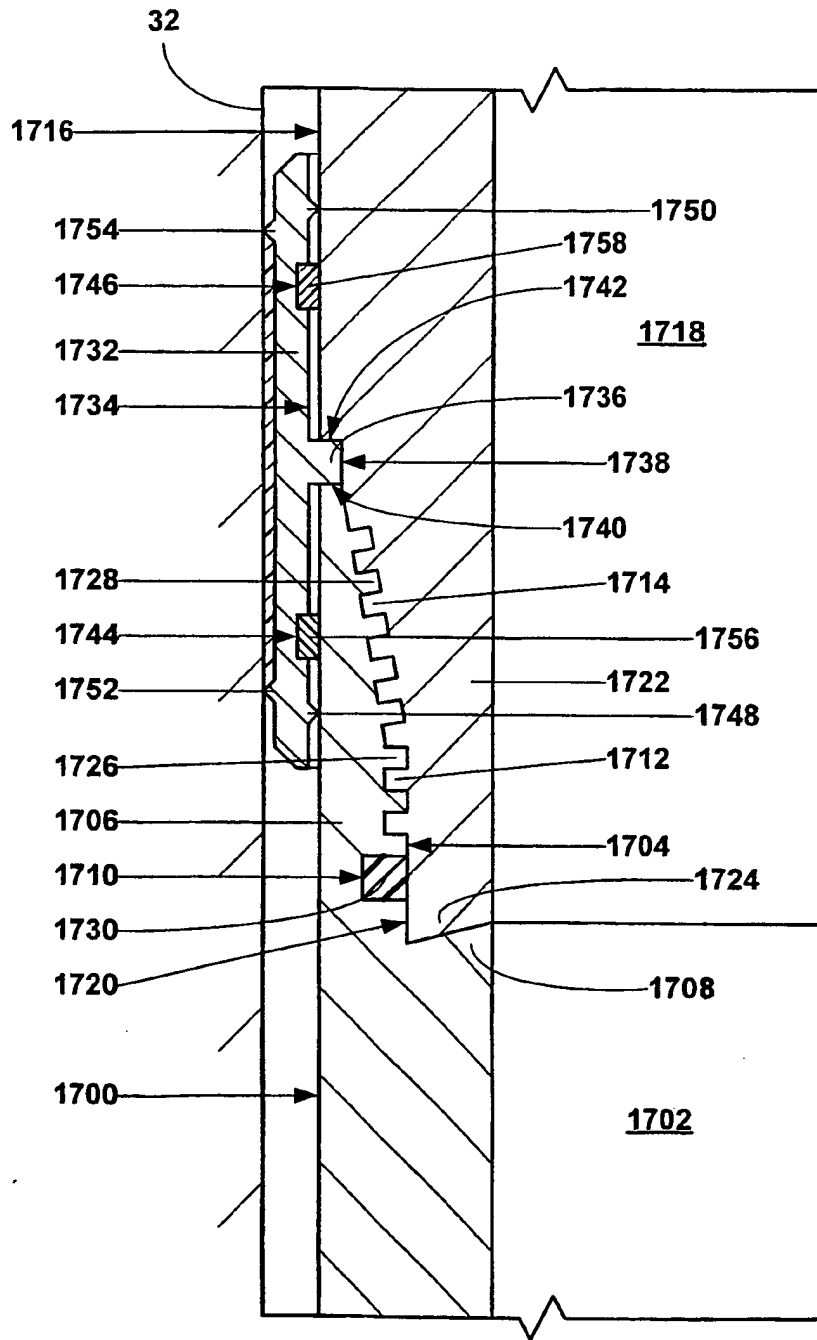
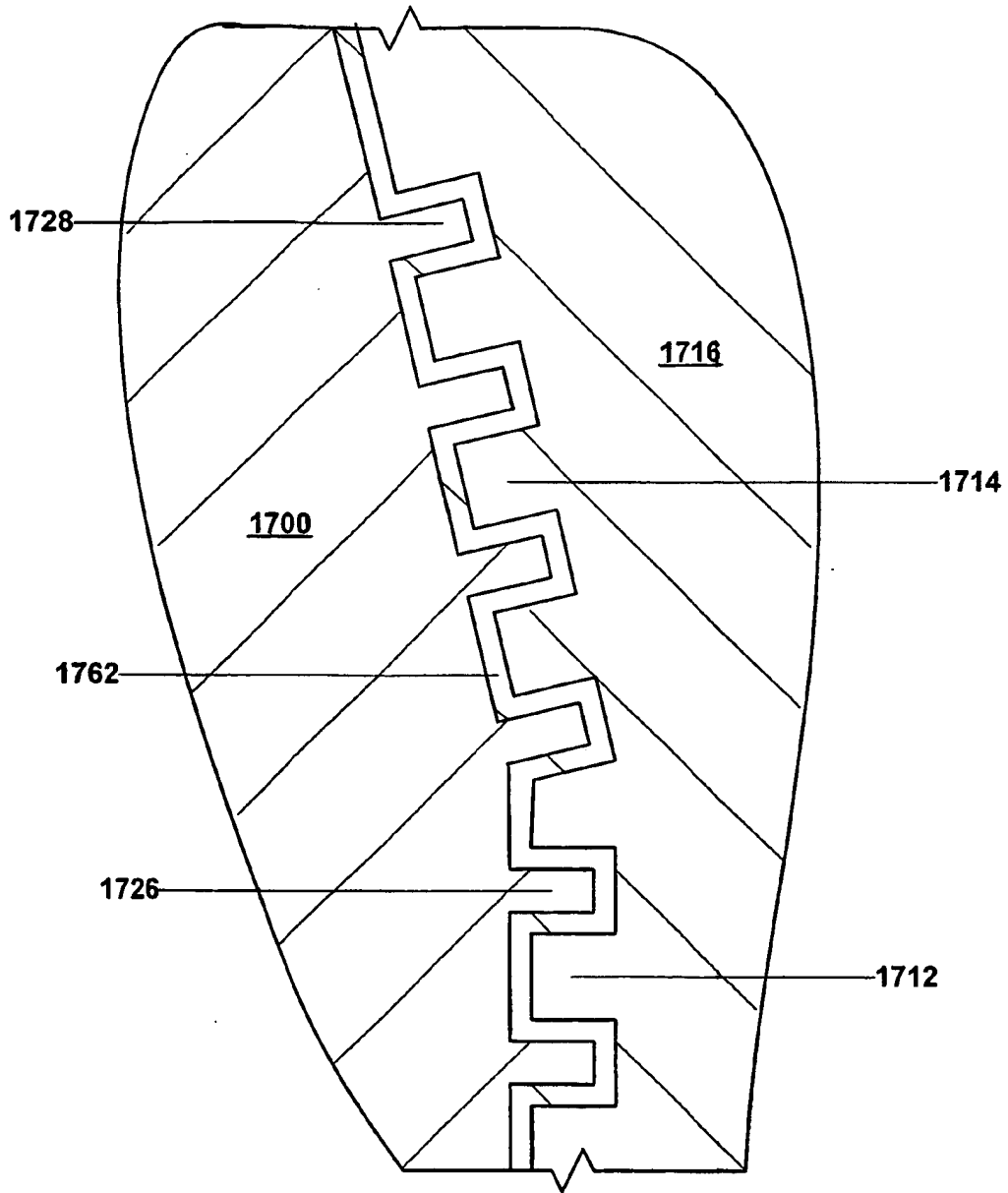

Fig. 15b



59/80

Fig. 15c

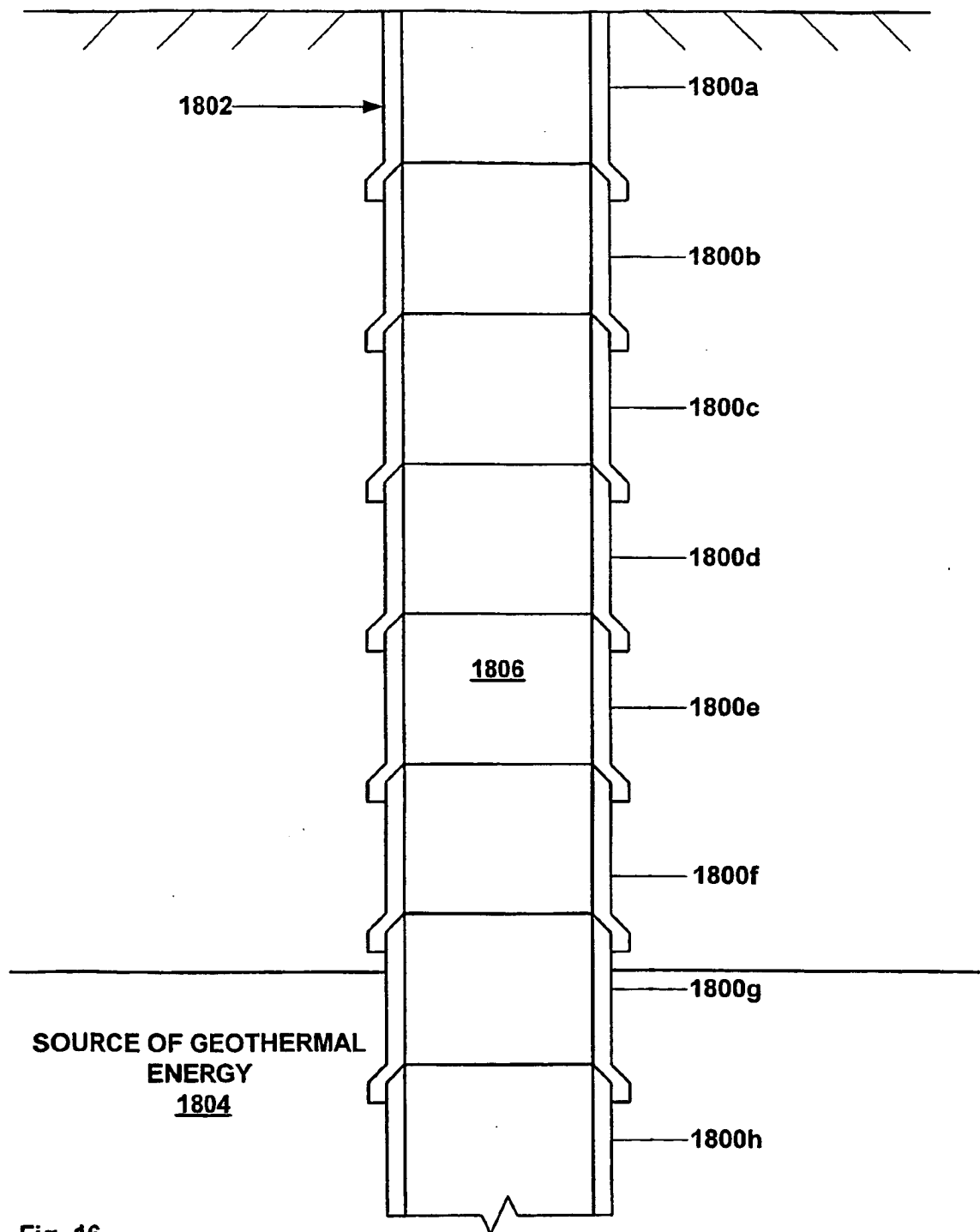

Fig. 16

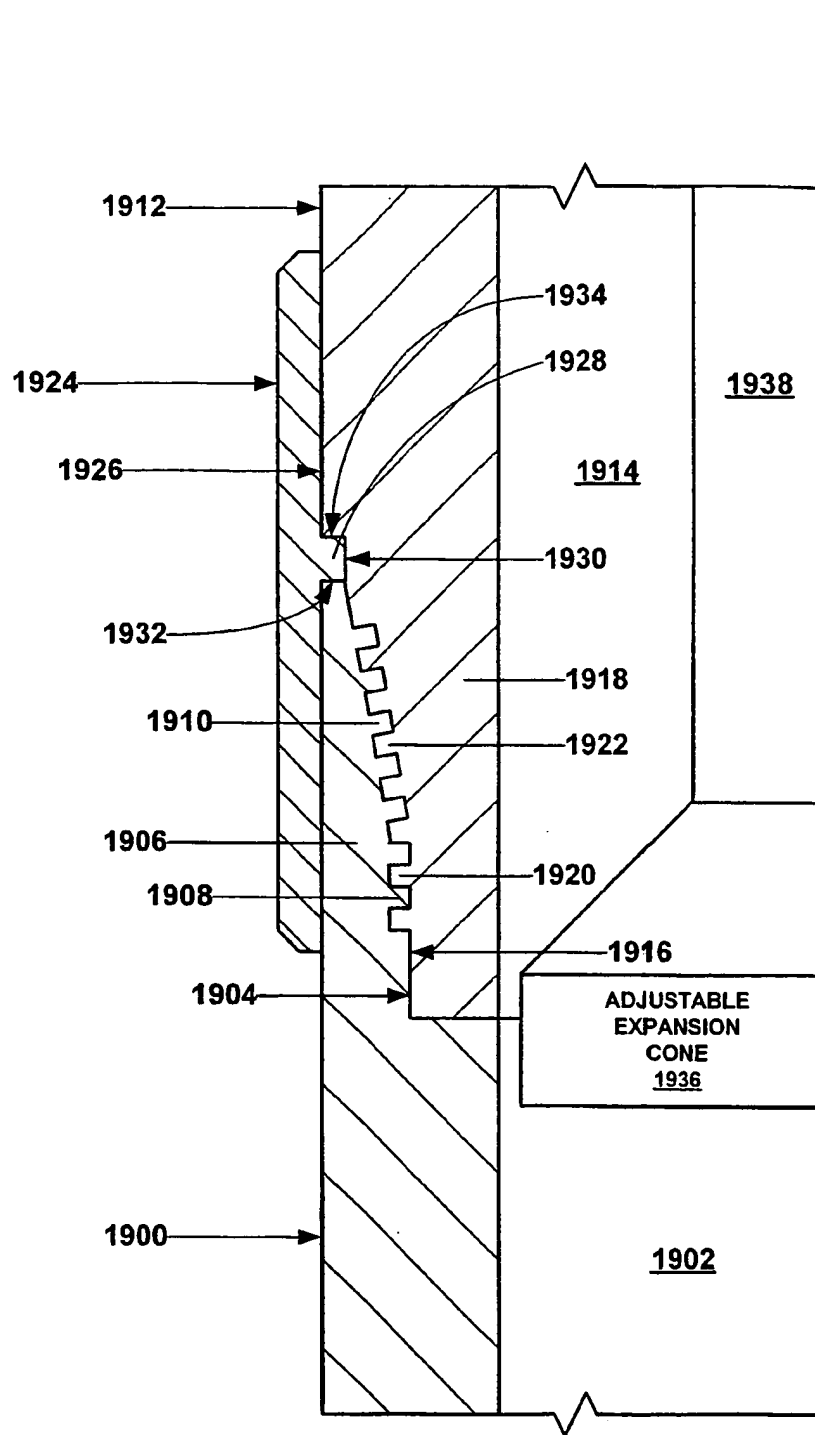

Fig. 17a

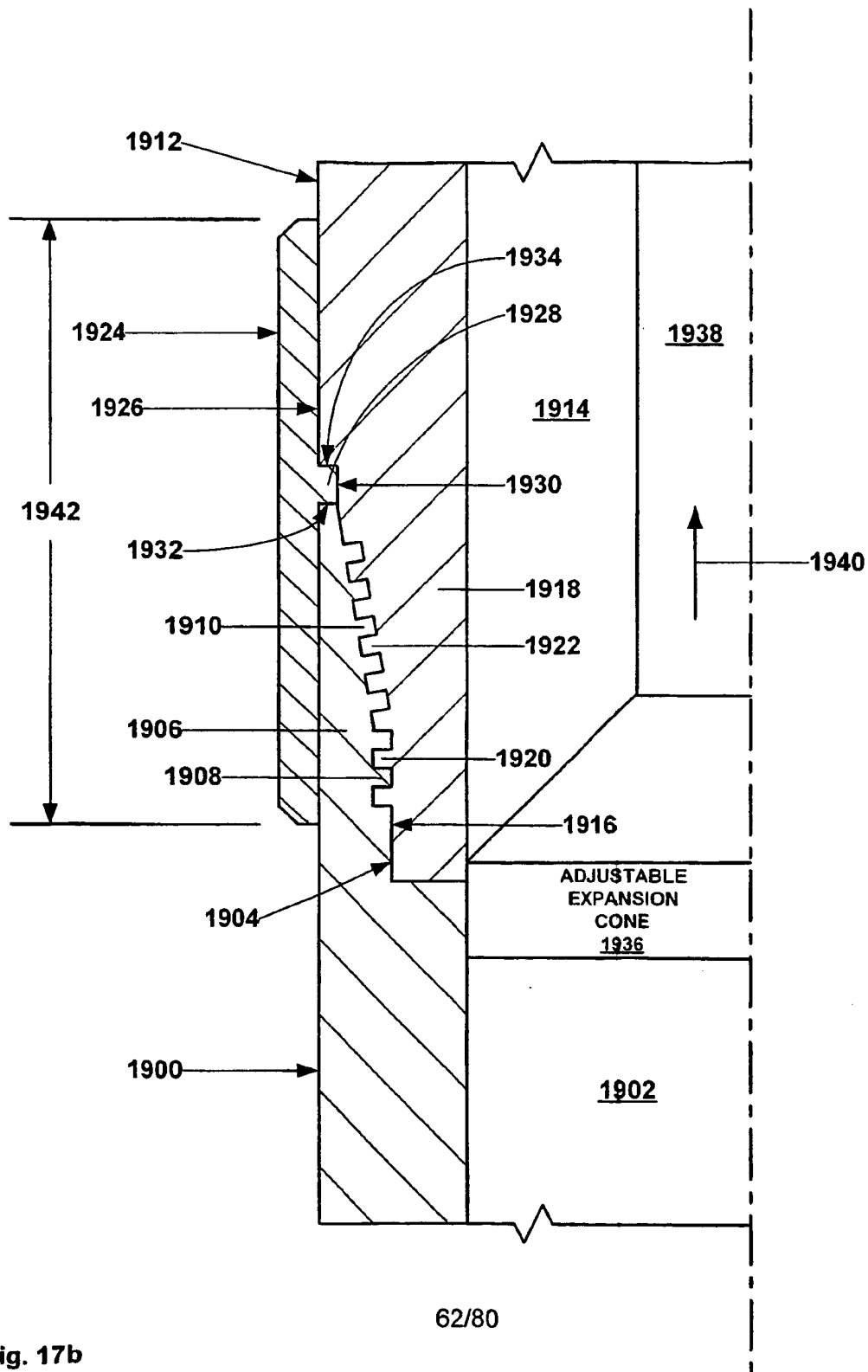

Fig. 17b

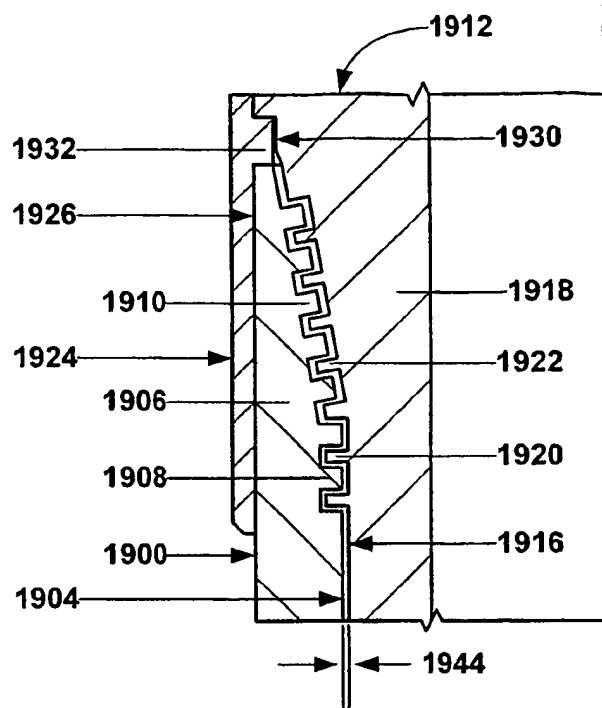

Fig. 17c

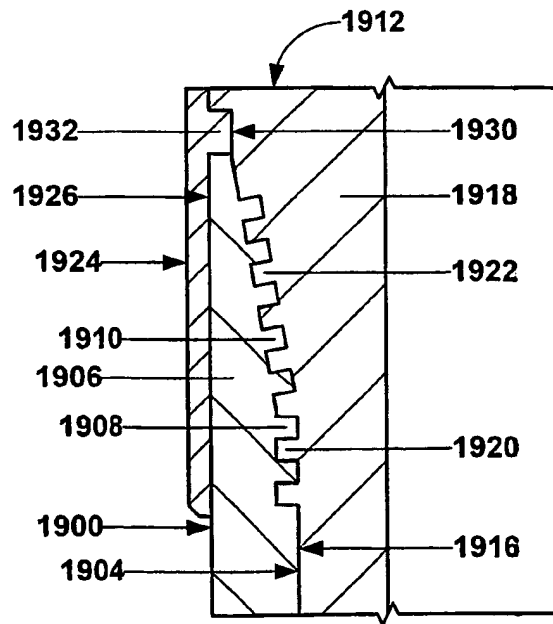
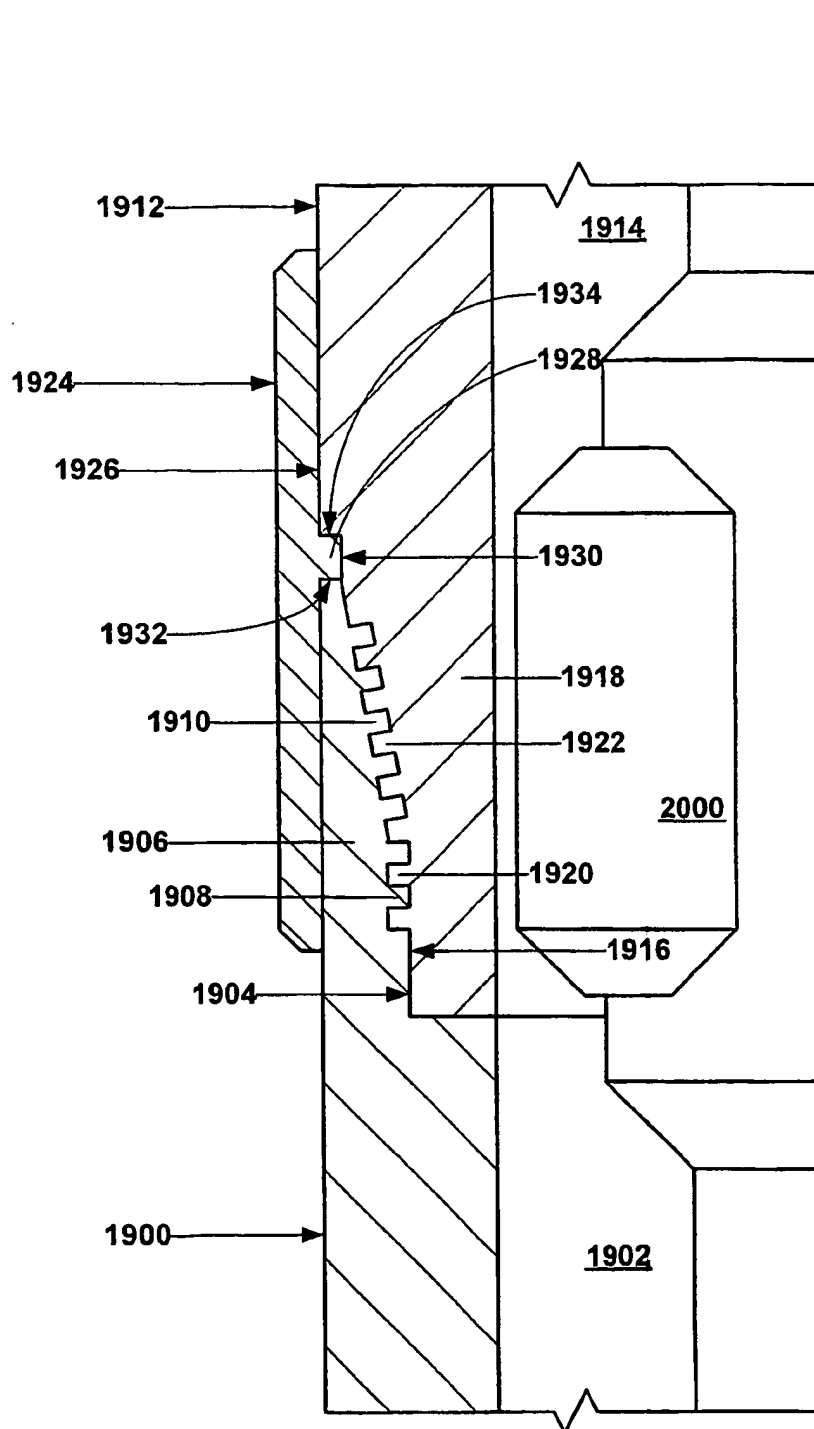

Fig. 17d



64/80

Fig. 18a

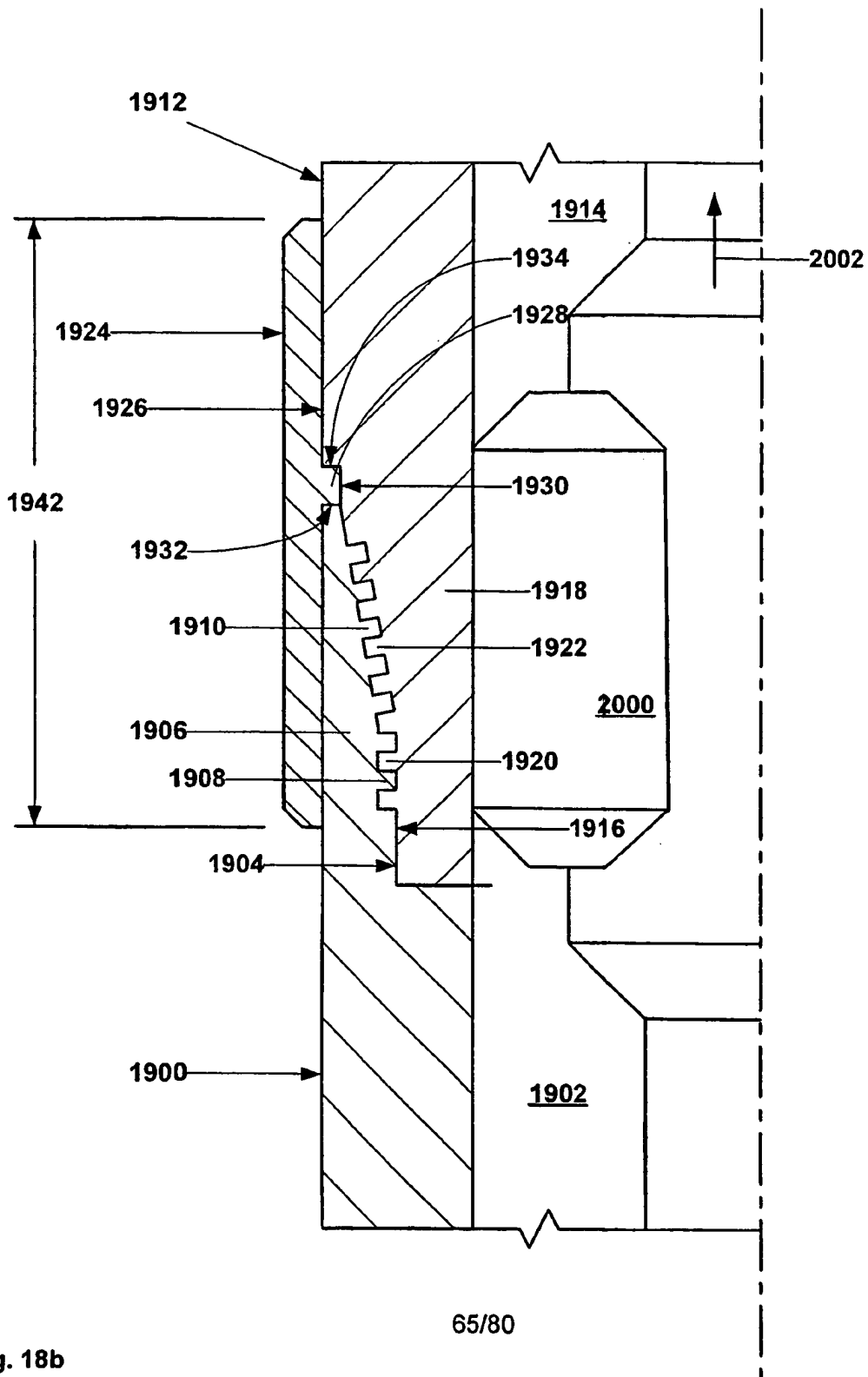

Fig. 18b

2100
↘

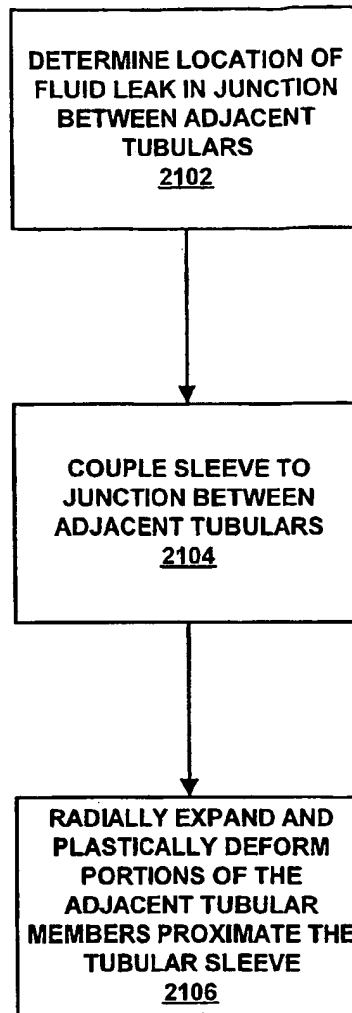

Fig. 19

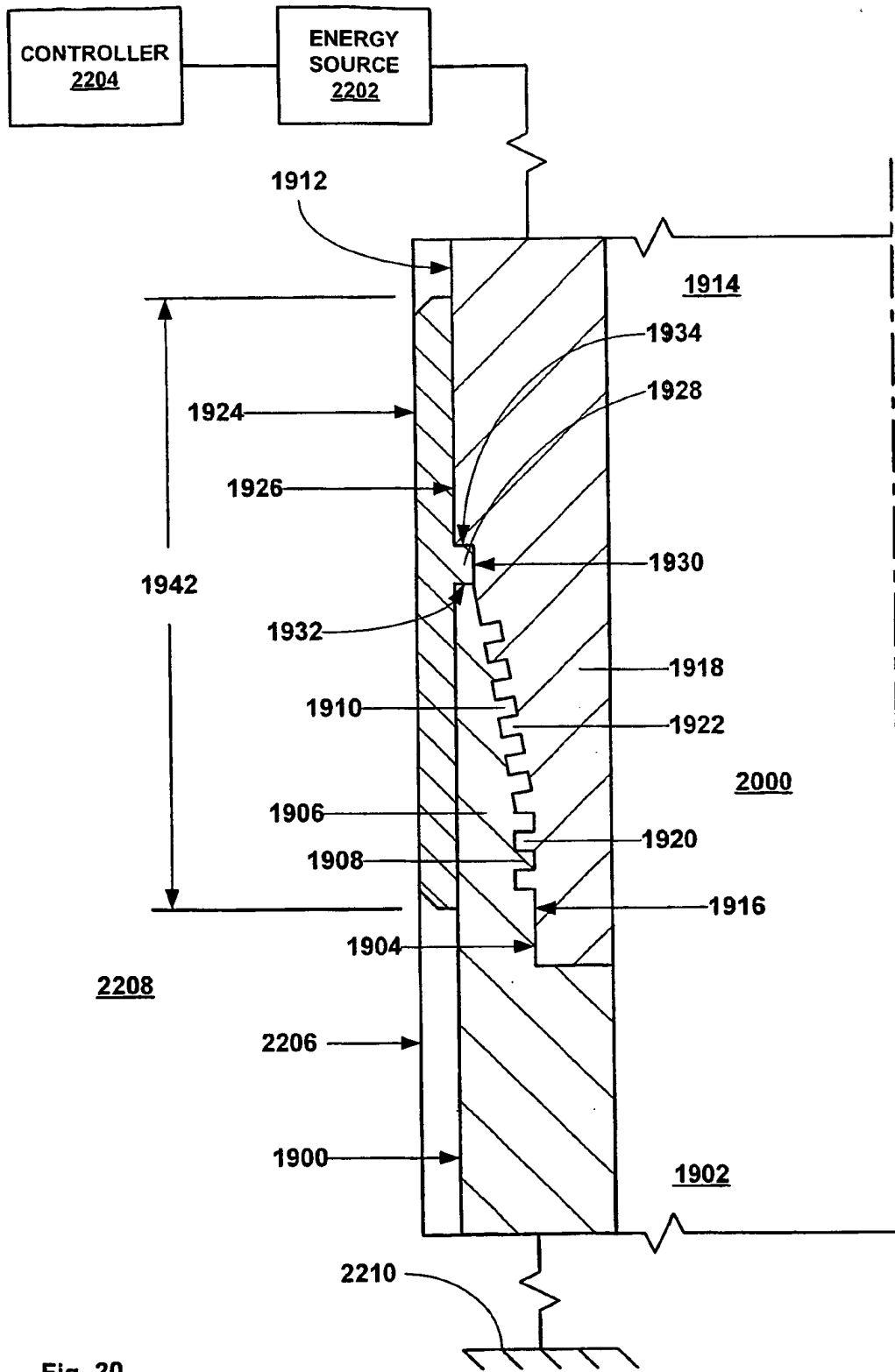

Fig. 20

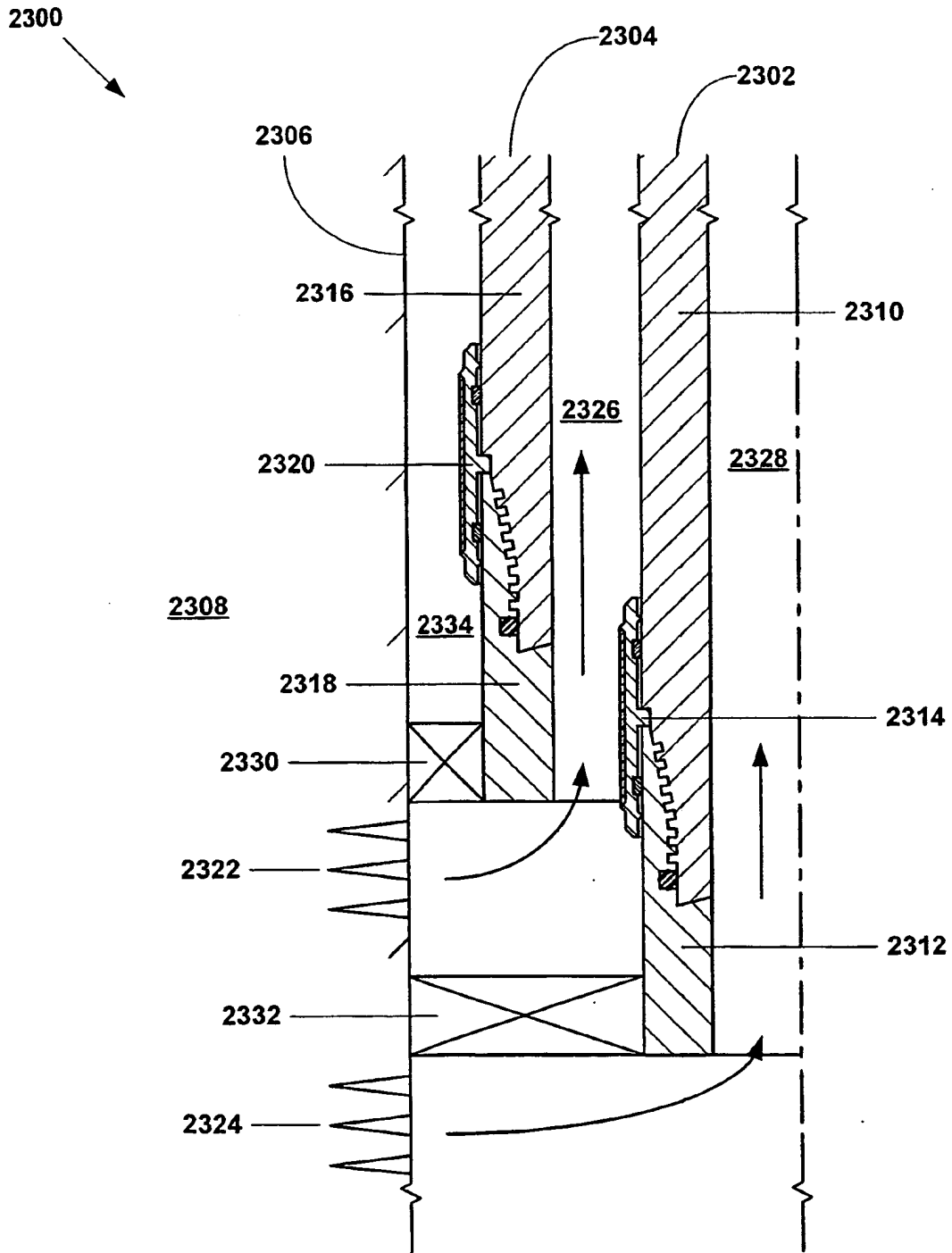
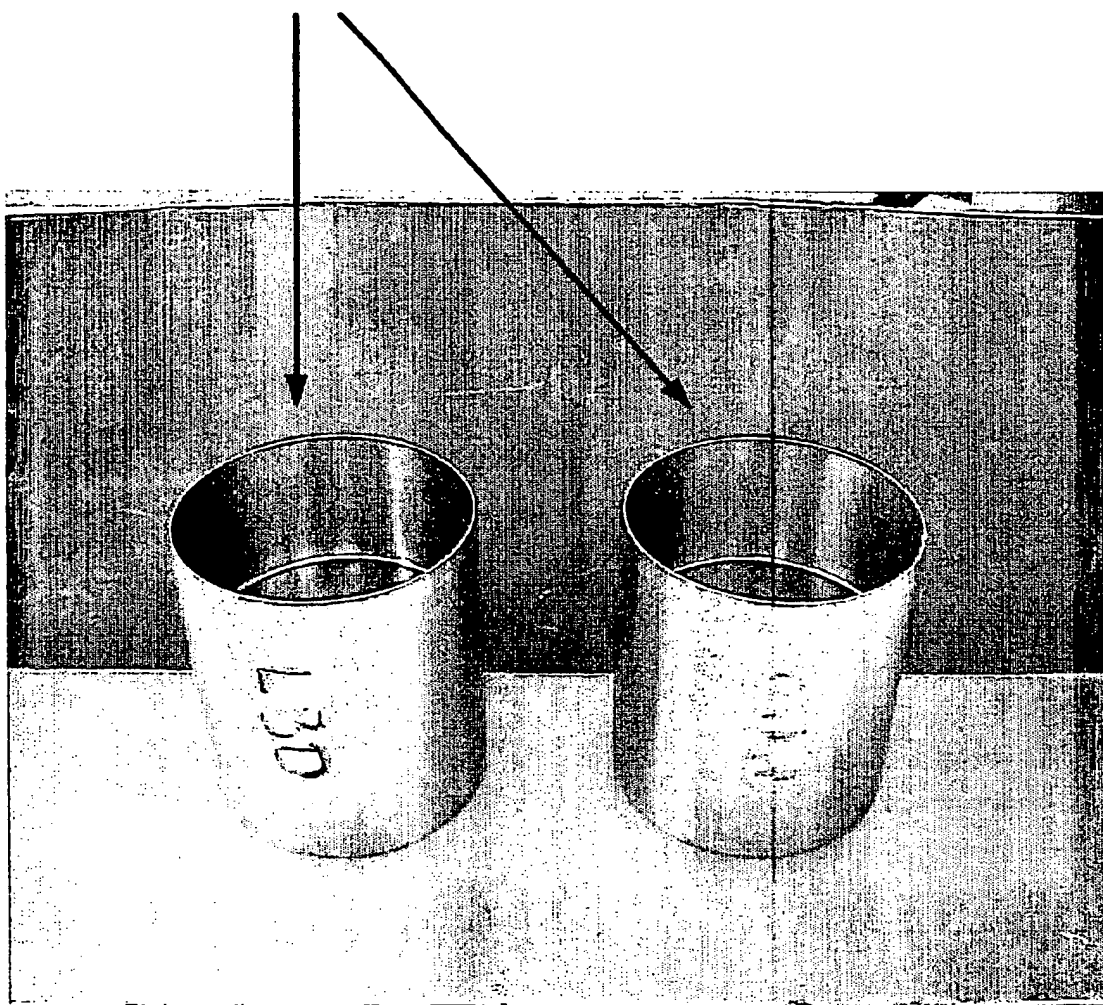
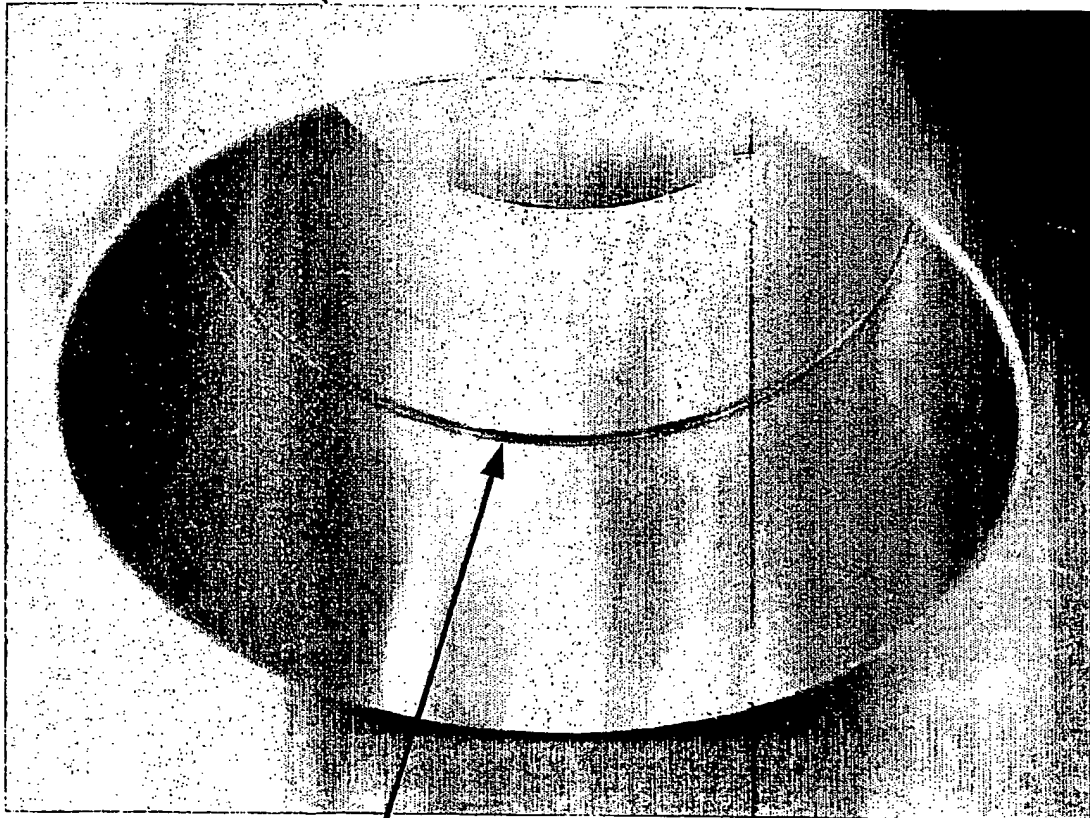

Fig. 21

SLEEVES



SLEEVE



INTERNAL FLANGE

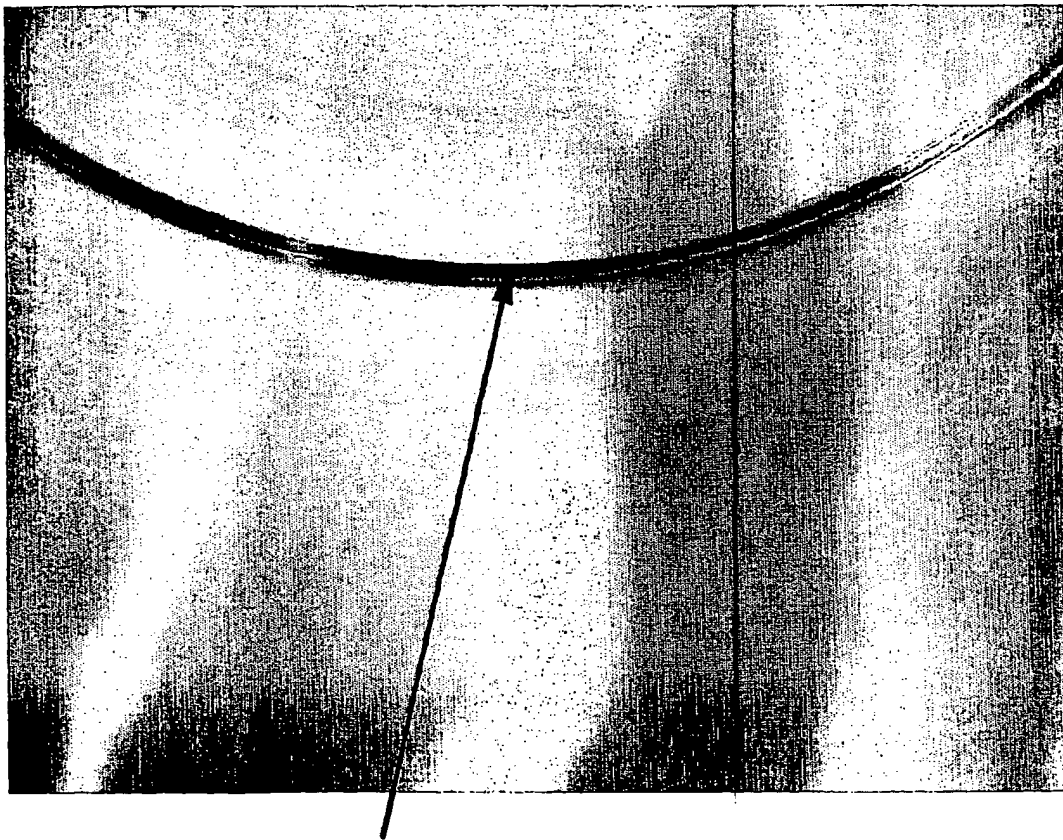

INTERNAL FLANGE

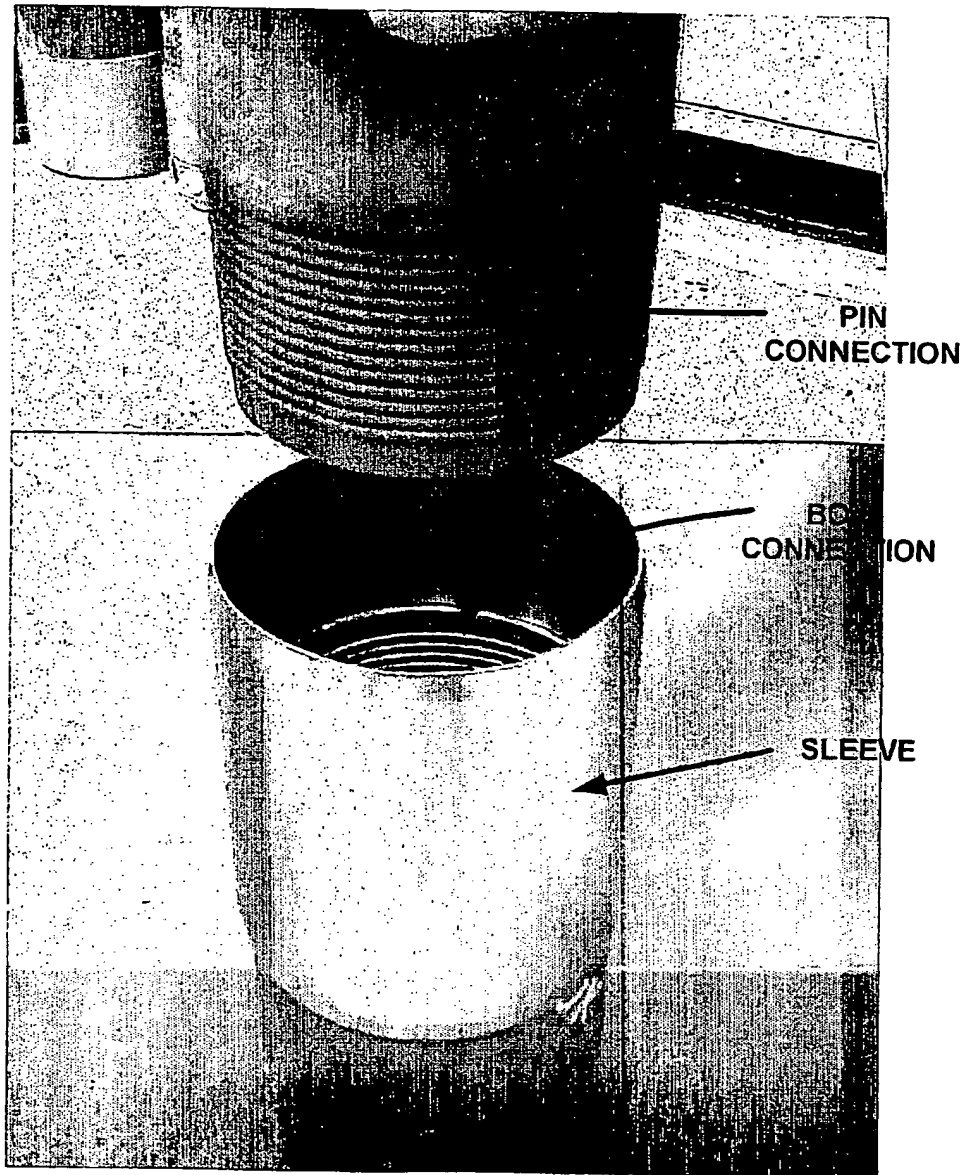

FULLY ASSEMBLED PIN AND BOX
THREADED CONNECTION WITH SLEEVE



PIN

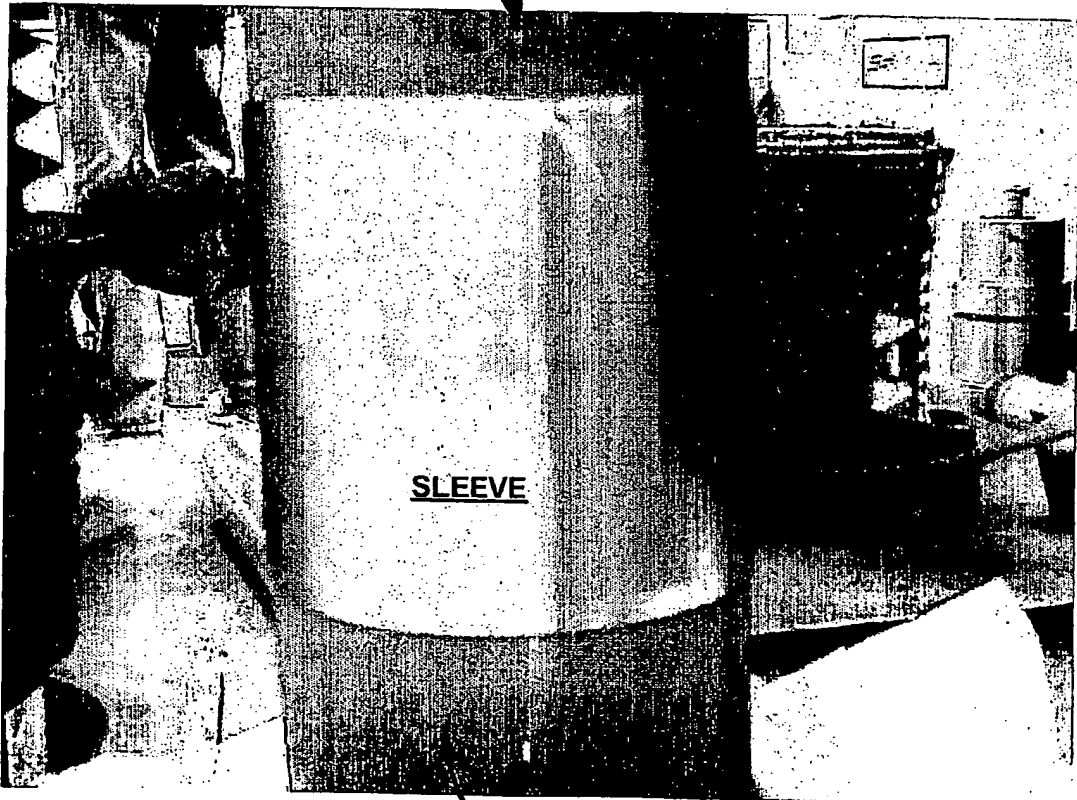

SLEEVE

BOX





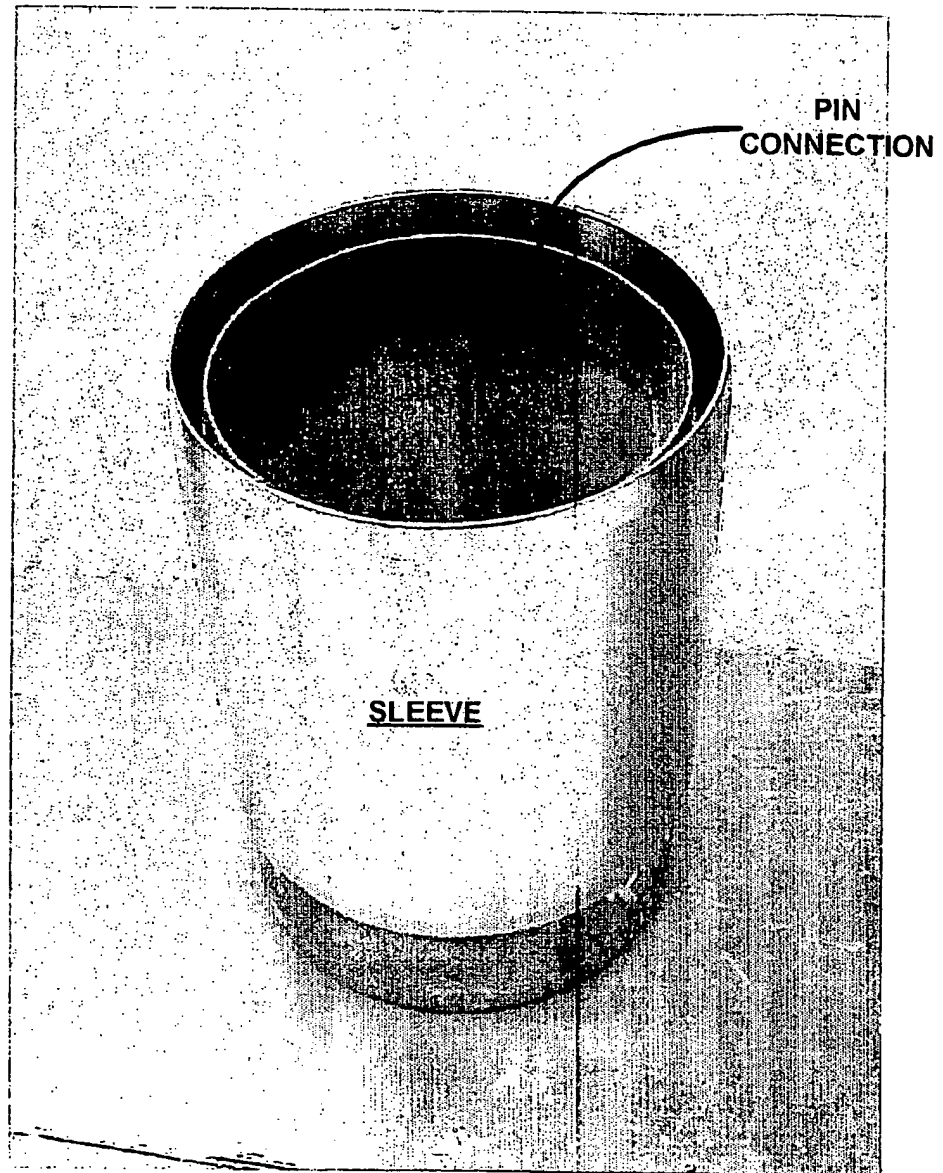

PIN CONNECTION

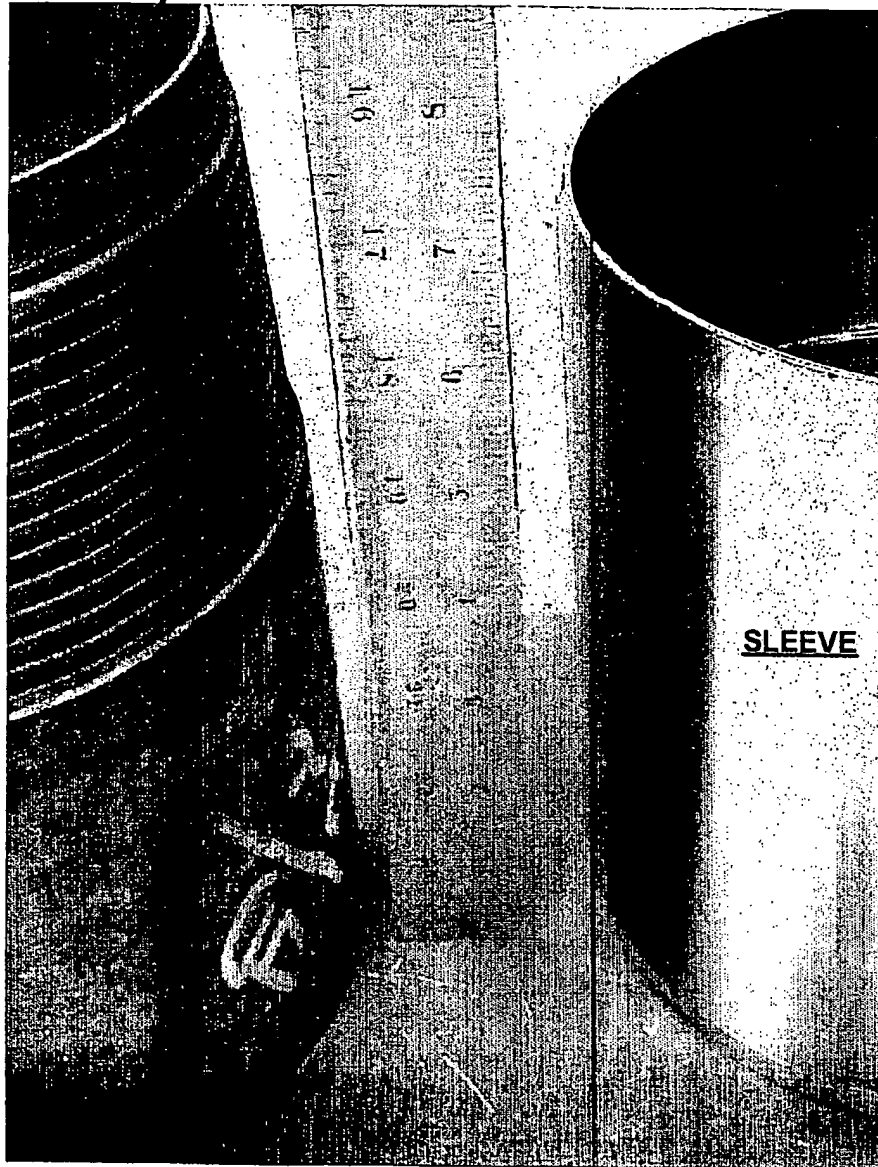

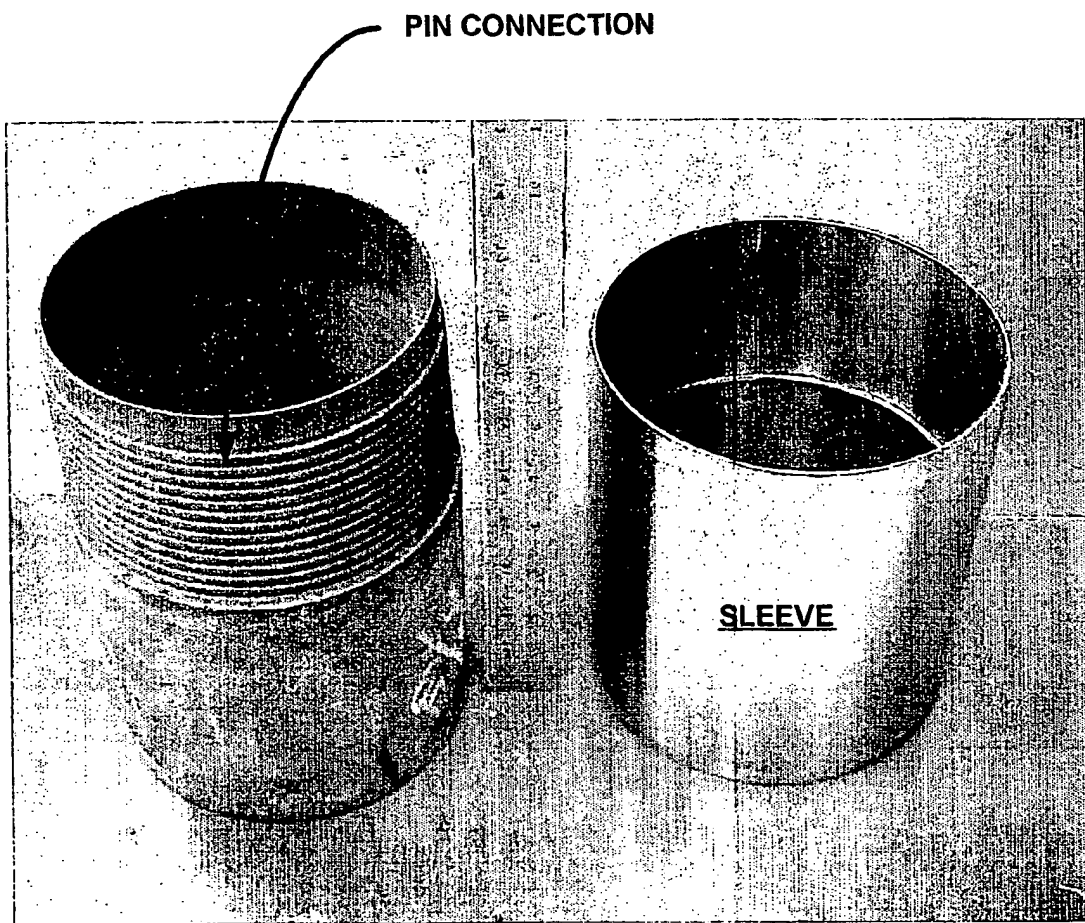

SLEEVE

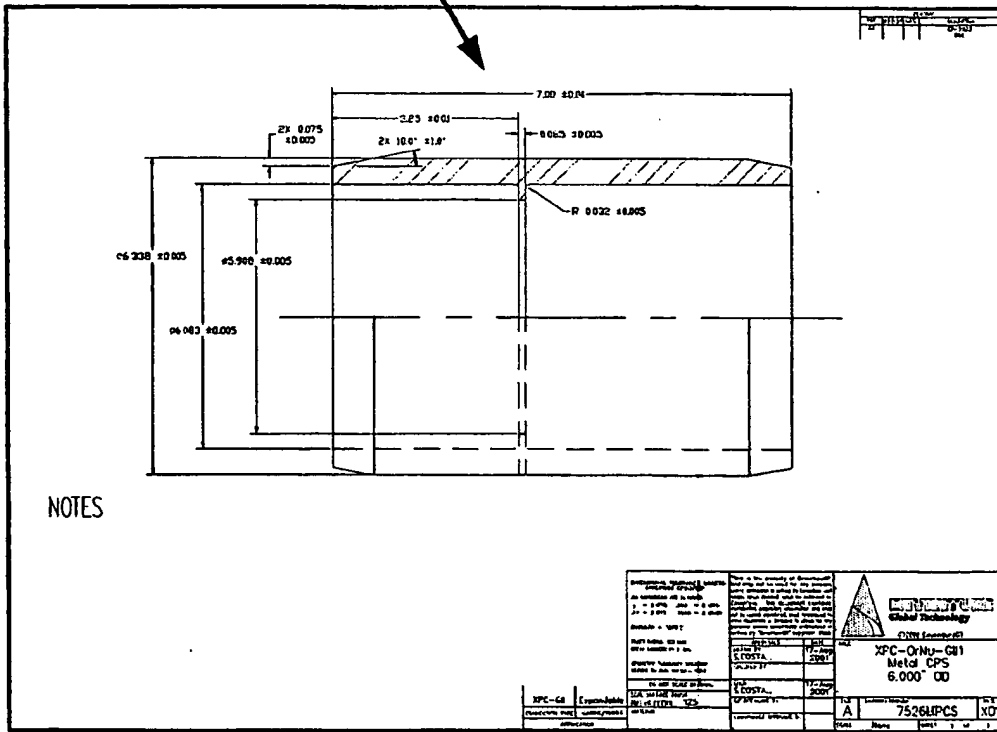

NOTES

SLEEVE

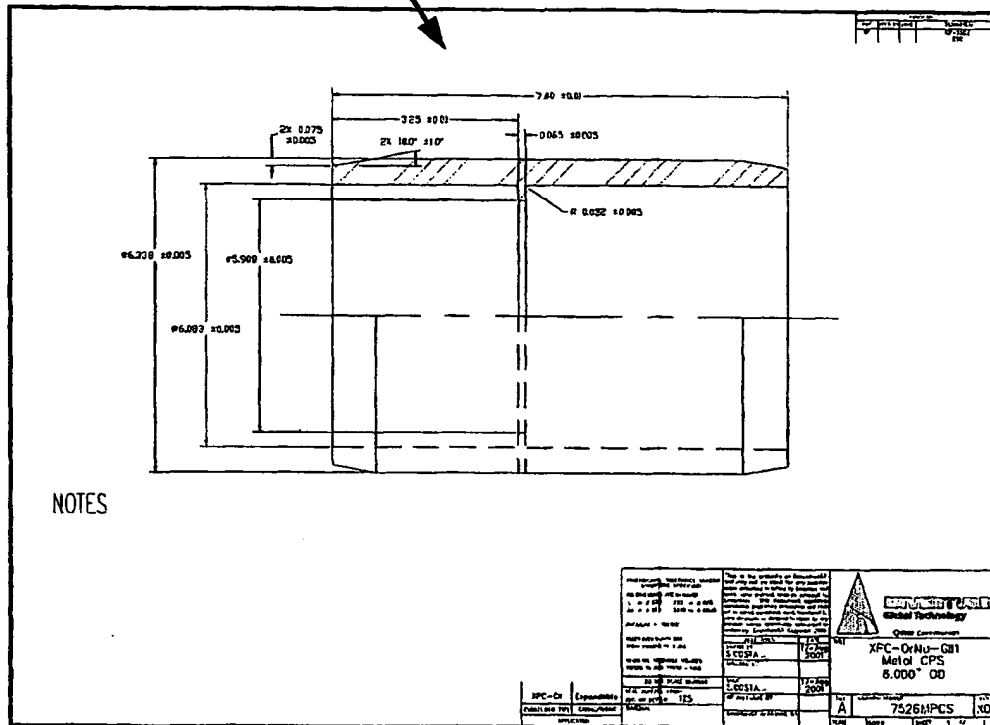

**CROSS SECTIONAL VIEW OF THREADED CONNECTION AFTER RADIAL
EXPANSION WITH EXTERNAL PROTECTIVE SLEEVE**

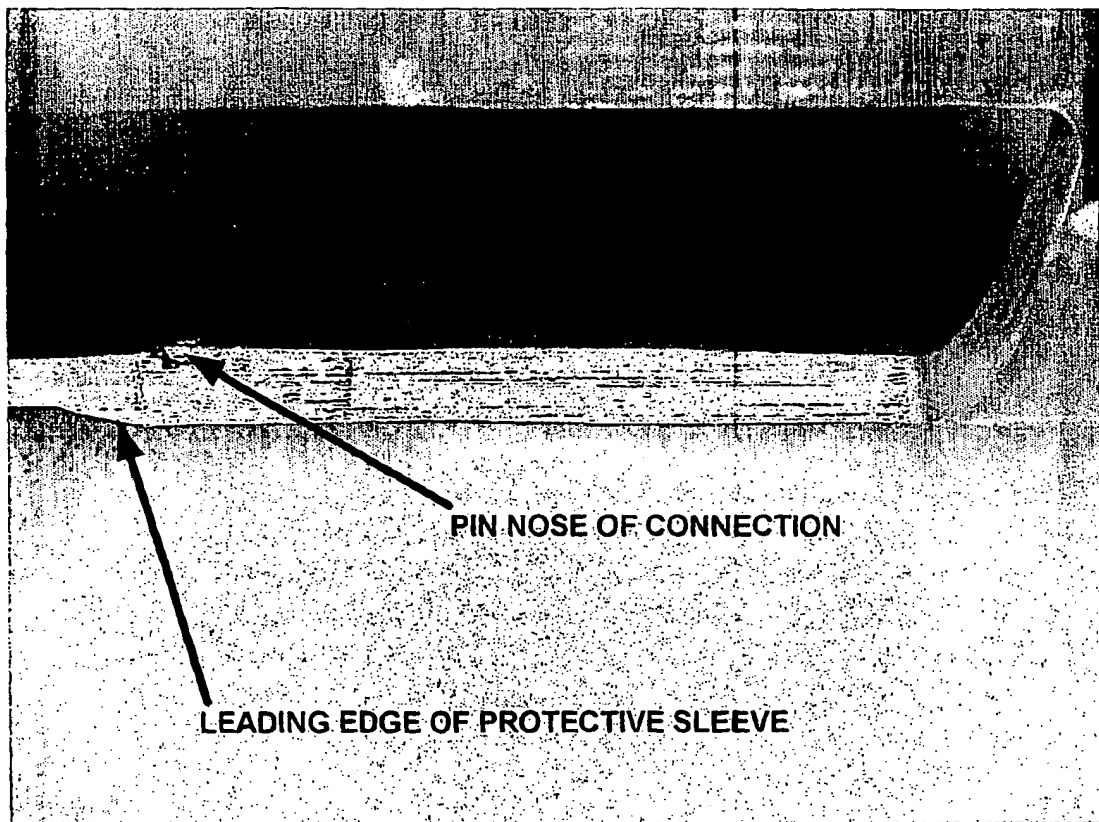

INTERNATIONAL SEARCH REPORT

International application No.

PCT/US03/20694

A. CLASSIFICATION OF SUBJECT MATTER
 IPC(7) : e21B 19/16
 US CL : 166/380, 85.3, 309, 387, 72, 73, 187, 195, 206, 207, 212, 216, 217; 285/382.7, 398, 55, 388.1
 According to International Patent Classification (IPC) or to both national classification and IPC

B. FIELDS SEARCHED
 Minimum documentation searched (classification system followed by classification symbols)
 U.S. : 166/380, 85.3, 309, 387, 72, 73, 187, 195, 206, 207, 212, 216, 217; 285/382.7, 398, 55, 388.1

Documentation searched other than minimum documentation to the extent that such documents are included in the fields searched
 NONE

Electronic data base consulted during the international search (name of data base and, where practicable, search terms used)
 EAST

C. DOCUMENTS CONSIDERED TO BE RELEVANT

Category *	Citation of document, with indication, where appropriate, of the relevant passages	Relevant to claim No.
X	US 4,693,498 A (BAUGH et al) 15 September 1987, see Fig. 2a and 2b	64
X	US 6,275,556 A (KINNEY et al) 14 August 2001, see Fig. 3	64
A	US 6,405,761 A (SHIMIZU et al) 18 June 2002	1-63
A	US 5,971,443 A (NOEL et al) 26 October 1999	1-63
A	5,309,621 A (O'DONNELL et al) 10 May 1994	1-63
A	US 3,997,193 A (TSUDA et al) 14 December 1976	1-63
A	US 3,989,280 A (SCHWARZ) 02 November 1976	1-63
A	US 3,834,742 A (MCPHILLIPS) 10 September 1974	1-63
A	US 3,579,805 A (KAST) 25 May 1971	1-63

Further documents are listed in the continuation of Box C. See patent family annex.

Special categories of cited documents:		
"A" document defining the general state of the art which is not considered to be of particular relevance	"T"	later document published after the international filing date or priority date and not in conflict with the application but cited to understand the principle or theory underlying the invention
"E" earlier application or patent published on or after the international filing date	"X"	document of particular relevance; the claimed invention cannot be considered novel or cannot be considered to involve an inventive step when the document is taken alone
"L" document which may throw doubts on priority claim(s) or which is cited to establish the publication date of another citation or other special reason (as specified)	"Y"	document of particular relevance; the claimed invention cannot be considered to involve an inventive step when the document is combined with one or more other such documents, such combination being obvious to a person skilled in the art
"O" document referring to an oral disclosure, use, exhibition or other means		
"P" document published prior to the international filing date but later than the priority date claimed	"&"	document member of the same patent family

Date of the actual completion of the international search: 07 October 2003 (07.10.2003)
 Date of mailing of the international search report: 12 NOV 2003

Name and mailing address of the ISA/US: Mail Stop PCT, Attn: ISA/US, Commissioner for Patents, P.O. Box 1450, Alexandria, Virginia 22313-1450. Facsimile No. (703)305-3230
 Authorized officer: Roger J. Schoepfel (with signature), Telephone No. (703) 306-4180

INTERNATIONAL SEARCH REPORT

PCT/US03/20694

C. (Continuation) DOCUMENTS CONSIDERED TO BE RELEVANT

Category *	Citation of document, with indication, where appropriate, of the relevant passages	Relevant to claim No.
A	US 2,647,847 A (BLACK et al) 04 August 1953	1-63

INTERNATIONAL SEARCH REPORT

International application No.

PCT/US03/20694

Box I Observations where certain claims were found unsearchable (Continuation of Item 1 of first sheet)

This international report has not been established in respect of certain claims under Article 17(2)(a) for the following reasons:

1. Claim Nos.:
because they relate to subject matter not required to be searched by this Authority, namely:

2. Claim Nos.:
because they relate to parts of the international application that do not comply with the prescribed requirements to such an extent that no meaningful international search can be carried out, specifically:

3. Claim Nos.:
because they are dependent claims and are not drafted in accordance with the second and third sentences of Rule 6.4(a).

Box II Observations where unity of invention is lacking (Continuation of Item 2 of first sheet)

This International Searching Authority found multiple inventions in this international application, as follows:
Please See Continuation Sheet

1. As all required additional search fees were timely paid by the applicant, this international search report covers all searchable claims.
2. As all searchable claims could be searched without effort justifying an additional fee, this Authority did not invite payment of any additional fee.
3. As only some of the required additional search fees were timely paid by the applicant, this international search report covers only those claims for which fees were paid, specifically claims Nos.:

4. No required additional search fees were timely paid by the applicant. Consequently, this international search report is restricted to the invention first mentioned in the claims; it is covered by claims Nos.:

Remark on Protest

The additional search fees were accompanied by the applicant's protest.

No protest accompanied the payment of additional search fees.

INTERNATIONAL SEARCH REPORT

PCT/US03/20694

BOX II. OBSERVATIONS WHERE UNITY OF INVENTION IS LACKING

This application contains the following inventions or groups of inventions which are not so linked as to form a single general inventive concept under PCT Rule 13.1. In order for all inventions to be examined, the appropriate additional examination fees must be paid.

Group I, claim(s) 1-63 and 142-158, drawn to a method.

Group II, claim(s) 64-127, drawn to an apparatus.

Group III, claim(s) 128-134, drawn to a method of extracting geothermal energy.

Group IV, claim(s) 135-141, drawn to an apparatus for extracting geothermal energy.

Group V, claim(s) 159-162 and 169-170, drawn to a borehole system.

Group VI, claim(s) 163-168, drawn to a method of operating a well.

The inventions listed as Groups I-VI do not relate to a single general inventive concept under PCT Rule 13.1 because, under PCT Rule 13.2, they lack the same or corresponding special technical features for the following reasons:

Group I comprises the method of radially deforming a tubular with plastic deformation whereas Group II does not make such a deformation. Groups III and IV comprise using a tubular subjected to radial deforming and plastic deformation in completing a geothermal energy well. The Groups are further distinguished in whether or not a flanged sleeve is used in making up a tubular string, whether or not a flange is external or internal, whether or not the connecting tubes are threaded, inter alia, such as whether or not seals are used in the connection of two tubulars.